



|| Jai Sri Gurudev ||

Sri AdichunchanagiriShikshana Trust®

SJB INSTITUTE OF TECHNOLOGY



(Affiliated to Visvesvaraya Technological University, Belagavi & Approved by AICTE, New Delhi. Accredited with NAAC 'A' grade)



Department of Mechanical Engineering



Course Material

BASIC THERMODYNAMICS

Semester & Section: **3rd Semester 'A' section**

Subject Name: **Basic Thermodynamics**

Subject Code: **18ME33**

Faculty Name: **Naveena kumar R. R.**

Designation: **Assistant Professor**

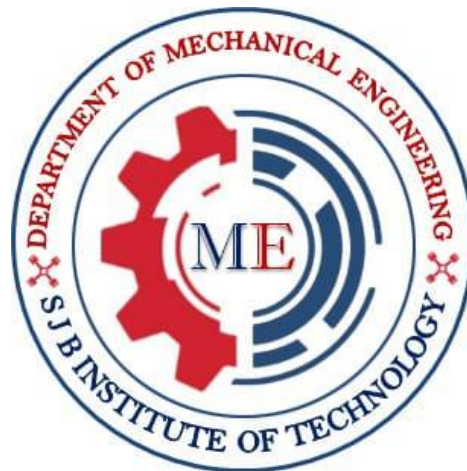

Academic year: **ODD Semester-2021-2022**

CONTENTS

1. Vision, Mission
2. POs, PSO's & PEOs
3. Blooms Taxonomy
4. Objectives and Outcomes
5. Course Syllabus
6. Lecture Notes (Unit-wise)
 - a. Notes
 - b. Industry applications relevant to the concepts covered
 - c. Assignment Question with self learning Materials

Vision of the Institute

- To become a recognized technical education center with global perspective.

Mission of the Institute

To provide learning opportunities that fosters students ethical values, intelligent development in science & technology and social responsibility so that they become sensible and contributing members of the society.

Vision of the Department

- To become a center of excellence and a platform in diversified fields for the aspirants in Mechanical Engineering.

Mission of the Department

- To impart comprehensive education in the field of mechanical engineering to produce highly accomplished graduates
- To endow high profile technical & soft skill trainings to foster professionalism and ethical values among students
- To inculcate innovative thinking among students through projects and research work

PROGRAM OUTCOMES

- 1. Engineering knowledge:** Apply the knowledge of mathematics, science, engineering fundamentals, and an engineering specialization to the solution of complex engineering problems.
- 2. Problem analysis:** Identify, formulate, review research literature, and analyze complex engineering problems reaching substantiated conclusions using first principles of mathematics, natural sciences, and engineering sciences.
- 3. Design/development of solutions:** Design solutions for complex engineering problems and design system components or processes that meet the specified needs with appropriate consideration for the public health and safety, and the cultural, societal, and environmental considerations.
- 4. Conduct investigations of complex problems:** Use research-based knowledge and research methods including design of experiments, analysis and interpretation of data, and synthesis of the information to provide valid conclusions.
- 5. Modern tool usage:** Create, select, and apply appropriate techniques, resources, and modern engineering and IT tools including prediction and modeling to complex engineering activities with an understanding of the limitations.
- 6. The engineer and society:** Apply reasoning informed by the contextual knowledge to assess societal, health, safety, legal and cultural issues and the consequent responsibilities relevant to the professional engineering practice.
- 7. Environment and sustainability:** Understand the impact of the professional engineering solutions in societal and environmental contexts, and demonstrate the knowledge of, and need for sustainable development.
- 8. Ethics:** Apply ethical principles and commit to professional ethics and responsibilities and norms of the engineering practice.
- 9. Individual and teamwork:** Function effectively as an individual, and as a member or leader in diverse teams, and in multidisciplinary settings.
- 10. Communication:** Communicate effectively on complex engineering activities with the engineering community and with society at large, such as, being able to comprehend and write effective reports and design documentation, make effective presentations, and give and receive clear instructions.
- 11. Project management and finance:** Demonstrate knowledge and understanding of the engineering and management principles and apply these to one's own work, as a member and leader in a team, to manage projects and in multidisciplinary environments.
- 12. Life-long learning:** Recognize the need for and have the preparation and ability to engage in independent and life-long learning in the broadest context of technological change.

PROGRAM EDUCATIONAL OBJECTIVES (PEO'S)

Enable the Graduates in Mechanical Engineering to:

PEO-1: Progress their career as a professional in mechanical engineering and Inter-disciplinary fields.

PEO-2: Become successful entrepreneur with social responsibilities and ethical values.

PEO-3: Pursue higher education and involve in research of allied areas in Mechanical Engineering.

PROGRAM SPECIFIC OUTCOMES (PSO'S)

After successful completion of Mechanical Engineering program, the graduates will be able to:

PSO1: Apply the Knowledge & Skill of Mechanical Engineering on Design, Manufacturing and Thermal platforms to address the real-life problem of the society.

PSO2: Design and implement new ideas with the help of CAD/CAM and Industrial Automation tools.

Blooms Taxonomy

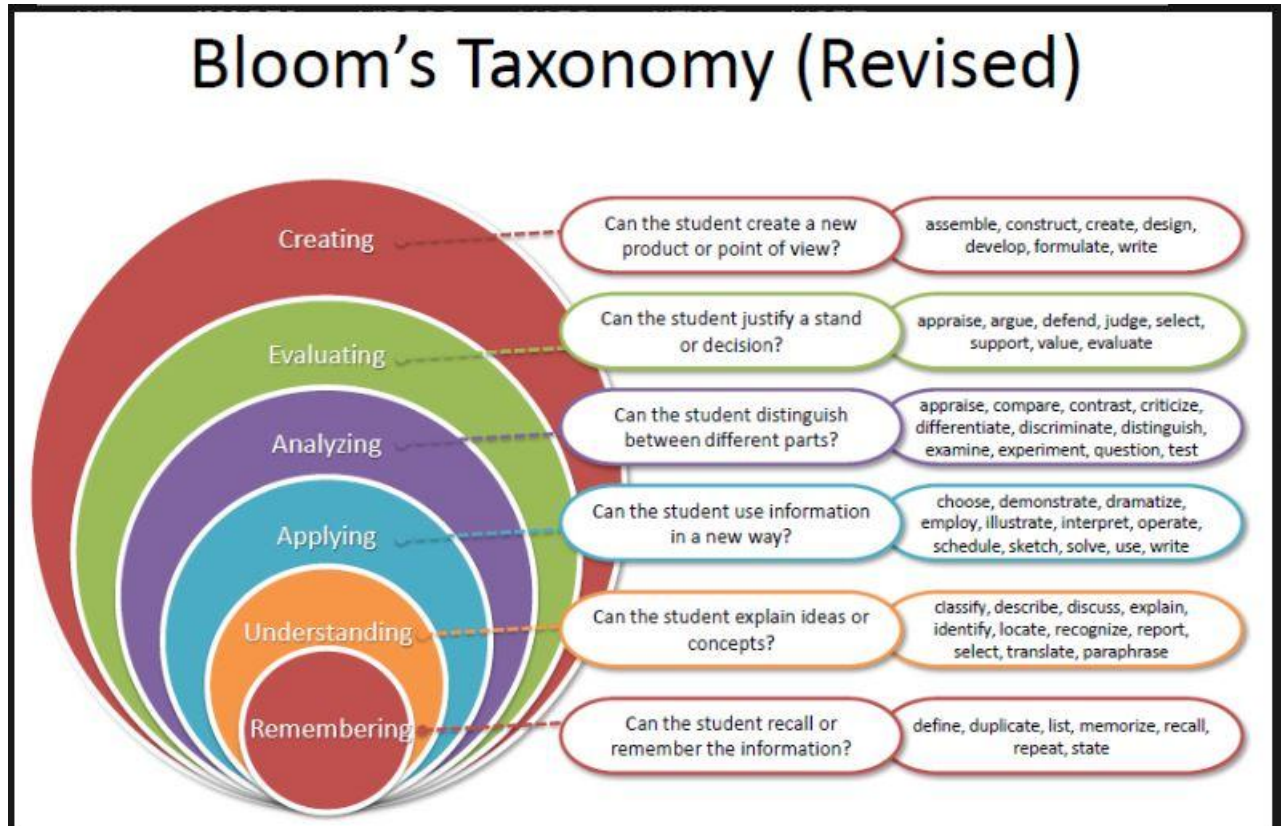

B. E. MECHANICAL ENGINEERING
Choice Based Credit System (CBCS) and Outcome Based Education (OBE)
SEMESTER - III
BASIC THERMODYNAMICS

Course Code 18ME33	CIE Marks 40
Teaching Hours/Week (L:T:P) 3:0:0	SEE Marks 60
Credits 03	Exam Hours 03

Course Learning Objectives:

- Learn about thermodynamic system and its equilibrium
- Understand various forms of energy - heat transfer and work
- Study the basic laws of thermodynamics including, zeroth law, first law and second law.
- Interpret the behaviour of pure substances and its application in practical problems.
- Study of Ideal and real gases and evaluation of thermodynamic properties

Module-1

Fundamental Concepts & Definitions: Thermodynamic definition and scope, Microscopic and Macroscopic approaches. Some practical applications of engineering thermodynamic Systems, Characteristics of system boundary and control surface, examples. Thermodynamic properties; definition and units, intensive, extensive properties, specific properties, pressure, specific volume, Thermodynamic state, state point, state diagram, path and process, quasi-static process, cyclic and non-cyclic; processes; Thermodynamic equilibrium; definition, mechanical equilibrium; diathermic wall, thermal equilibrium, chemical equilibrium, Zeroth law of thermodynamics, Temperature; concepts, scales, international fixed points and measurement of temperature. Constant volume gas thermometer, constant pressure gasthermometer, mercury in glass thermometer.

Module-2

Work and Heat: Mechanics, definition of work and its limitations. Thermodynamic definition of work; examples, sign convention. Displacement work; as a part of a system boundary, as a whole of a system boundary, expressions for displacement work in various processes through p-v diagrams. Shaft work; Electrical work. Other types of work. Heat; definition, units and sign convention. Problems.

First Law of Thermodynamics: Joules experiments, equivalence of heat and work. Statement of the First law of thermodynamics, extension of the First law to non - cyclic processes, energy, energy as a property, modes of energy, Extension of the First law to control volume; steady flow energy equation(SFEE), important

Module-3

Second Law of Thermodynamics: Limitations of first law of thermodynamics, Thermal reservoir, heat engine and heat pump: Schematic representation, efficiency and COP. Reversed heat engine, schematic representation, importance and superiority of a reversible heat engine and irreversible processes, internal and external reversibility. Kelvin - Planck statement of the Second law of Thermodynamics; PMM I and PMM II, Clausius statement of Second law of Thermodynamics, Equivalence of the two statements; Carnot cycle, Carnot principles. Problems

Entropy: Clausius inequality, Statement- proof, Entropy- definition, a property, change of entropy, entropy as a quantitative test for irreversibility, principle of increase in entropy, entropy as a coordinate.

Module-4

Availability, Irreversibility and General Thermodynamic relations. Introduction, Availability (Exergy), Unavailable energy, Relation between increase in unavailable energy and increase in entropy. Maximum work, maximum useful work for a system and control volume, irreversibility. Pure Substances: P-T and P-V diagrams, triple point and critical points. Sub-cooled liquid, saturated liquid, mixture of saturated liquid and vapor, saturated vapor and superheated vapor states of pure substance with water as example. Enthalpy of change of phase (Latent heat). Dryness fraction (quality), T-S and H-S diagrams, representation of various processes on these diagrams. Steam tables and its use. Throttling calorimeter, separating and throttling calorimeter.

Module-5

Ideal gases: Ideal gas mixtures, Daltons law of partial pressures, Amagat's law of additive volumes, evaluation of properties of perfect and ideal gases, Air- Water mixtures and related properties.

Real gases: Introduction, Van-der Waal's Equation of state, Van-der Waal's constants in terms of critical properties, Beattie-Bridgeman equation, Law of corresponding states, compressibility factor; compressibility chart. Difference between Ideal and real gases.

Course Outcomes: At the end of the course, the student will be able to:

CO1: Explain fundamentals of thermodynamics and evaluate energy interactions across the boundary of thermodynamic systems.

CO2: Evaluate the feasibility of cyclic and non-cyclic processes using 2nd law of thermodynamics.

CO3: Apply the knowledge of entropy, reversibility and irreversibility to solve numerical problems and apply 1st law of thermodynamics to closed and open systems and determine quantity of energy transfers and change in properties.

CO4: Interpret the behavior of pure substances and its application in practical problems.

CO5: Recognize differences between ideal and real gases and evaluate thermodynamic properties of ideal and real gas mixtures using various relations.

Question paper pattern:

- The question paper will have ten full questions carrying equal marks.
- Each full question will be for 20 marks.
- There will be two full questions (with a maximum of four sub- questions) from each module.
- Each full question will have sub- question covering all the topics under a module.
- The students will have to answer five full questions, selecting one full question from each module.

Textbooks

1. Basic and Applied Thermodynamics, P.K.Nag, Tata McGraw Hill 2nd Ed., 2002
2. Basic Engineering Thermodynamics, A.Venkatesh Universities Press, 2008
3. Basic Thermodynamics,, B.K Venkanna, Swati B. Wadavadagi PHI, New Delhi 2010

Reference Books

1. Thermodynamics- An, Engineering Approach, YunusA.Cenegal and Michael A.Boles Tata McGraw Hill publications 2002
2. An Introduction to Thermodynamcis, Y.V.C.Rao Wiley Eastern 1993,
3. Engineering Thermodynamics .B.Jones and G.A.Hawkins John Wiley and Sons.

Module 1

FUNDAMENTAL CONCEPTS AND DEFINITIONS

INTRODUCTION:

Thermodynamics is the science of energy transfer and its effect on the physical properties of substances. The alternate definition is: thermodynamics is the science that deals with work and heat and these properties of substances that bear a relation to heat and work. Like all sciences, the basis of thermodynamics is experimental observation.

Thermodynamics (from the Greek *therme*, meaning "heat" and *dynamis*, meaning "power") is a branch of physics that studies the effects of changes in temperature, pressure, and volume on physical systems at the macroscopic scale by analyzing the collective motion of their particles using statistics. This subject was developed mainly by

- 1) Carnot
- 2) Mayer
- 3) Clausius
- 4) Joule
- 5) Kelvin
- 6) Maxwell
- 7) Plank
- 8) Gibbs

A thermodynamic system is a device or combination of devices containing a quantity of matter that is being studied. A typical **thermodynamic system** - heat moves from hot (boiler) to cold (condenser), and work is extracted, in this case by a series of pistons.

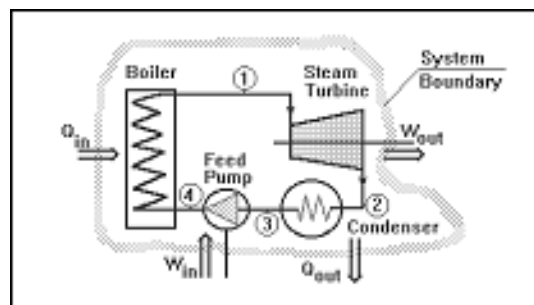

A typical thermodynamic system

The study of thermodynamics is the basis of such fields as steam power plants, IC Engines, Gas dynamics and aerodynamics, fluid mechanics, Refrigeration and Air conditioning and

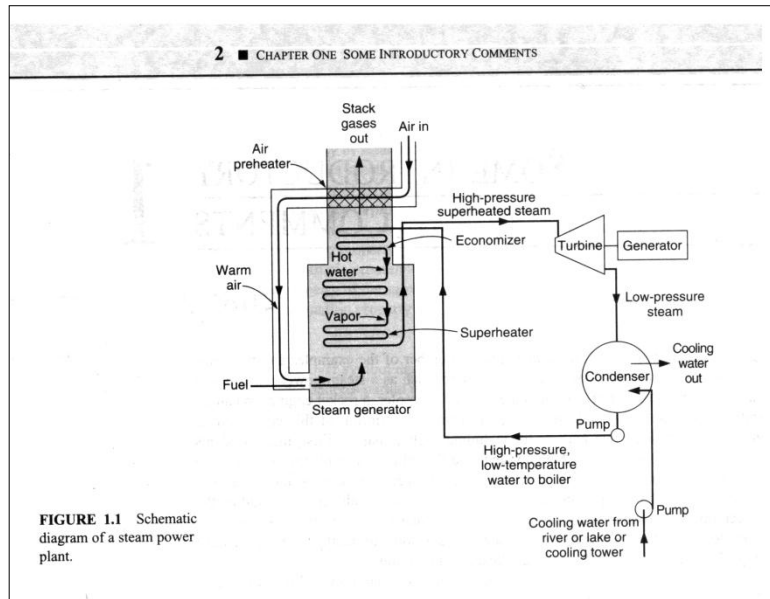

A Steam Power Plant

Thermodynamics deals with four laws. Namely Zeroth law, first law, second law and Third law of thermodynamics. Fortunately, there is no mathematical proof for any of these laws of thermodynamics, like physical laws, but they are deduced from experimental observations.

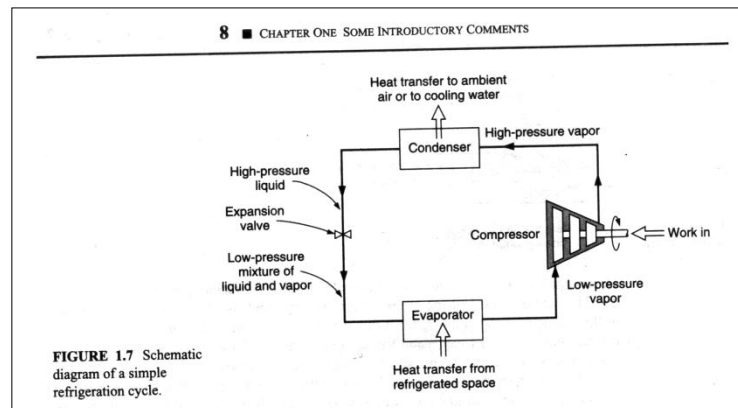

Refrigeration Cycle

Thermodynamics deals with three E's, namely Energy, Equilibrium and Entropy. Thermodynamics also talks about study of materials, chemical reactions, plasmas and other biological reactions.

Macroscopic and Microscopic point of view:

This study deals with macroscopic, as opposed to microscopic or statistical thermodynamics. In microscopic thermodynamics individual molecule is considered and analysis of collective molecular action. In macroscopic thermodynamics, we concern ourselves with the overall effect of the individual molecular interaction.

Macroscopic point of view: The macroscopic level is the level on which we live. We measure most of the quantities on this level.

Ex: Temperature measurement, pressure measurement, total volume measurement, specific volume measurement. Thus, microscopic point of view will be used only to explain some phenomena that can't be understood by macroscopic means.

Microscopic point of view: Considers a system containing a cube of 25 mm containing monoatomic gas at atmospheric pressure and temperature. This volume contains approx. 10^{20} atoms. To describe the position of each atom in a coordinate system we require three equations. To describe the velocity of each atom we have to specify 3 velocity components. Thus to describe completely the behavior of the system from a microscopic point of view we must deal at least 6×10^{20} equations. It is a hopeless computational task.

The other approach that reduces number of variables to a few that can be handled is the macroscopic point of view of Classical Thermodynamics. It concerns with the gross or average effect of many molecules and can be measured by instruments. This measurement is the time-averaged influence of many molecules.

In the present study, we concentrate on macroscopic point of view.

Statistical thermodynamics, classical thermodynamics deals with the significance of microscopic point of approach. From the macroscopic point of view it is very clear that continuum has to be there in the system because we are not concerned with the behavior of the individual molecule.

Substance: What follows will be illustrations of the thermodynamics, one must be able to solve problems and to do what the part of the problem must be enumerated. The first consideration is that there must be something performing the energy transformations. This something is called a substance. Ex: In case of IC engine gasoline and air mixture constitutes the substance. In steam turbine the substance is steam.

The substance may be further divided into sub categories, namely pure substance i.e. if it is homogeneous in nature- i.e. if it does not undergo chemical reaction and is not a mechanical mixture of different spices. The other substance is a mixture substance which is not a pure substance.

Thermodynamic System:

A substance does not exist alone. It must be contained. This brings us to the concept of a system.

In thermodynamics a system is defined as any collection of matter or space of fixed identity, the concept is one of the most important thermodynamics.

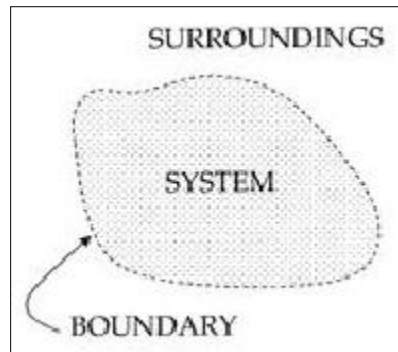

Concept of a Boundary

System boundary: When a system is defined, let us say, fluid in a cylinder, what separates the fluid from the cylinder wall and the piston and everything external to the piston-cylinder? it is the system boundary. Everything not in the system is called the surrounding. Note that piston can be raised or lowered, but the system, matter of fixed identity is constant.

The system is further divided into closed system, open system and isolated system.

Thermodynamic System

A Thermodynamic system is defined as a quantity of matter or a region in space upon which attention is concentrated in the analysis of a problem. Everything external to the system is called the surrounding or environment. The system is separated from the surrounding by the system boundary. Boundary may be either fixed or moving. A system and its surrounding together comprise a universe.

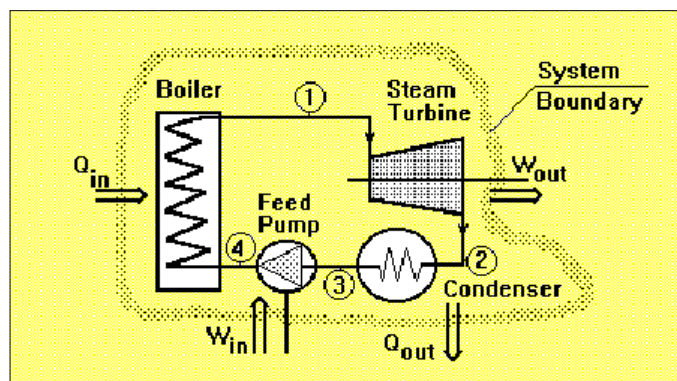

A System, Surroundings and Boundary

Open System: The open system is one in which matter crosses the boundary of the system. There may be energy transfer also. Most of the engineering devices are generally open systems. Ex: An air compressor in which air enters at low pressure and leave at high pressure and there is energy transfer across the system boundary.

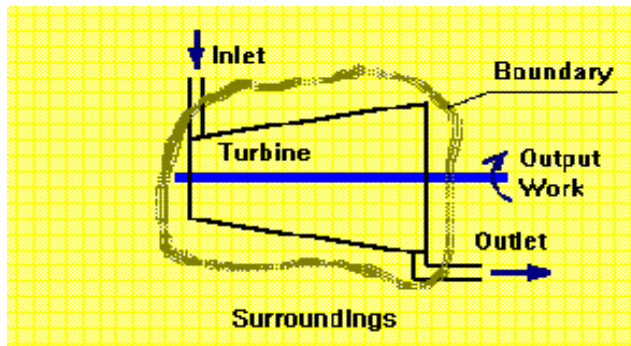

An Open System

Closed System: A closed system is a system of fixed mass. There is no mass transfer across the system boundary. Ex: A certain quantity of fluid in a cylinder bounded by a piston constitutes a closed system.

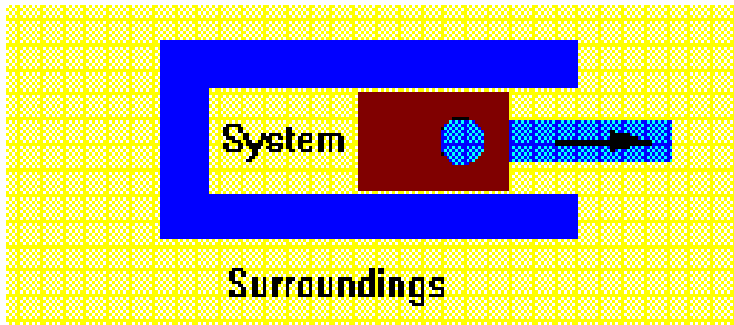

A Closed System

Isolated System: The isolated system is one in which there is no interaction between the system and surrounding. It is of the fixed mass and energy and there is no mass or energy transfer across the system boundary.

Control Volume and Control Surface:

In thermodynamic analysis of an open system such as air compressor, gas turbine in which there is a flow of mass into and out of the system, attention is focused on a certain volume in space surrounding the compressor known as control volume, bounded by a surface called the control surface. Matter as well as energy can cross the control surface.

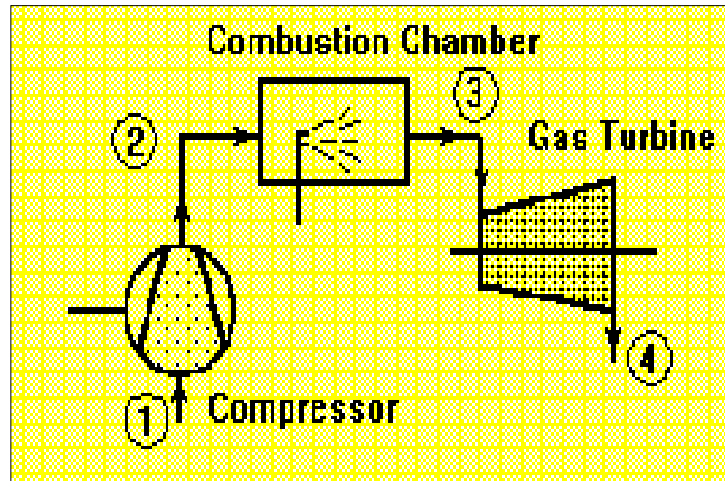

Gas turbine

Homogeneous and Heterogeneous system:

A quantity of matter homogeneous throughout in chemical composition and physical structure is called a phase. Every substance can exist in any one of the three phases viz. Solid, Liquid or gas.

A system consisting of a single phase is called a homogeneous system while a system consisting of more than one phase is known as a heterogeneous system.

THERMODYNAMIC PROPERTIES

Thermodynamic properties are taken from a macroscopic perspective. We are dealing with quantities that can either directly or indirectly be measured or counted. Therefore, the matter of units becomes an important consideration.

Mass, length and time are considered as fundamental physical quantities, they are related by Newton's second law of motion, which states that the force acting on a body is proportional to the product of mass and acceleration in the direction of force.

$$\text{i.e. } \mathbf{F} = \mathbf{m} * \mathbf{a}$$

Mass – kg

Length – m

Time – s

This is adopted by CGPM- General Conference of Weights and Measures

In thermodynamics temperature is also considered as fundamental unit in Kelvin.

Energy: One of the very important concepts in a study of thermodynamics is the concept of energy. It is defined as the capacity to do work. It is also defined as the capability to produce an effect

When considered from molecular point of view, three general forms of energy become important.

- 1) Intermolecular potential energy.
- 2) Molecular kinetic energy
- 3) Intermolecular energy.

The energy is the important concept which depends on the mass, velocity, intermolecular attraction. In all intermolecular internal energy is most difficult to evaluate.

Specific Volume: It is a macroscopic property and defined as the volume occupied by unit mass. It is reciprocal of density and its unit is m^3/kg . The specific volume of a system in a gravitational field may vary from point to point. Specific volume increases as the elevation increases. Thus the definition of specific volume involves the specific volume of a substance at a point in a system.

Pressure: The pressure in a fluid at rest at a given point is the same in all directions. We define pressure as the normal component of force per unit area. Its unit is pascal or N/m^2 . When dealing with liquids and gases we ordinarily speak of pressure. For solids we speak of stresses.

Two other units not part of international system continue to be widely used are

Bar = 10^5 Pa = 0.1MPa and standard atmosphere is 1 atm = 101325 Pa.

In most thermodynamic investigations, we are concerned with absolute pressure. Most pressure vacuum gauges however read the difference between the absolute pressure and the atmospheric pressure at the gauge. This refers to as gauge pressure.

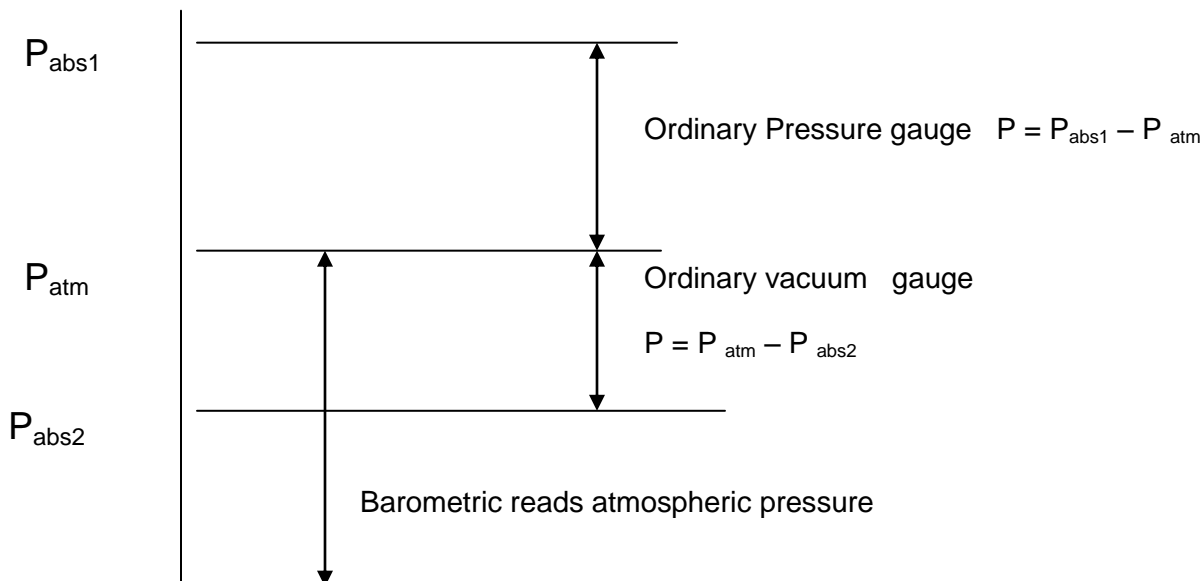

Temperature: It is a fundamental property of thermodynamics and defined as the hotness of the body. Temperature first of all as a sense of hotness or coldness when we touch an object. We also learn that when a hot body and a cold body are brought into contact the hot body becomes cooler and cold body becomes warmer. Because of these difficulties in defining temperature we define equality of temperature.

Property: It is defined as any quantity that depends on the state of the system and is independent of the path (i.e. the prior history) by which the system arrived at the given state. Conversely the state is specified or described by the properties and later we will consider the number of independent properties a substance can have, i.e, the minimum number of properties that must be specified to fix the state of a substance.

Thermodynamic properties can be divided into 2 general classes: intensive and extensive properties:

Intensive property: An intensive property is independent of mass; thus intensive property value remains same even if the matter is divided into two equal parts. Ex: pressure, temperature, density etc.

Extensive Property: The value of an extensive property varies directly with the mass, i.e. if a quantity of matter in given state is divided into 2 equal parts, the properties will have the half the original values. Ex: mass, total volume, total enthalpy, total energy etc.

Thermodynamic State Point:

The state may be identified or described by certain observable macroscopic properties; some familiar one are temperature, pressure and density. The state is specified or described by the properties. The state point can be indicated on a thermodynamic coordinate system. Thermodynamic coordinate system includes pressure volume diagram, temperature volume diagram, temperature entropy diagram, enthalpy entropy diagram, pressure enthalpy diagram so on and so forth.

These co-ordinate systems represent thermodynamic state of a substance. Consider a system not undergoing any change. At this point all the properties can be measured or calculated throughout the entire system, which gives us a set of properties that completely, describes the condition or the state of the system.

Thermodynamics deals with equilibrium state. When a system undergoes any change then change of state will occur.

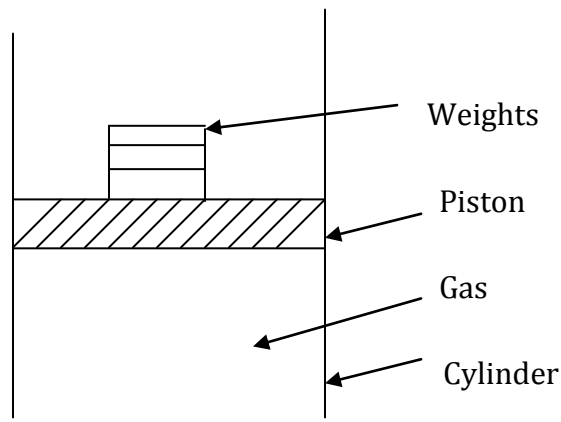

Piston Cylinder arrangement

Process: Whenever one or more of the properties of a system change we say that a change in state has occurred. For ex: in a piston and cylinder arrangement, if weight is removed from the piston rises and change in state occurs in which pressure decreases and specific volume increases. The path of succession of states through which the system passes is called process.

Path: Path is the complete series of states through which the system passes during a change from one given state to other state. It is clear that the transformation of a system from one fixed state to another state is called a process.

The thermodynamic processes that are commonly met within engineering practice are 1) Constant pressure process (Isobaric) 2) Constant volume process(Isochoric) 3)Constant temperature process(Isothermal) 4) Reversible adiabatic process (Isentropic process) 5) Polytropic, process 6) Throttling process.

If the system passes through a series of equilibrium states during the process it's called reversible process. On the other hand the system passes through a series of non-equilibrium states during a process it is called irreversible process. The state of the processes cannot be plotted on the co-ordinate systems since the path of the process is not defined.

Generally the system is in equilibrium in the beginning and at the end of the process, the reversible process can be plotted on the coordinate diagram by continuous line and an irreversible process by a dotted line.

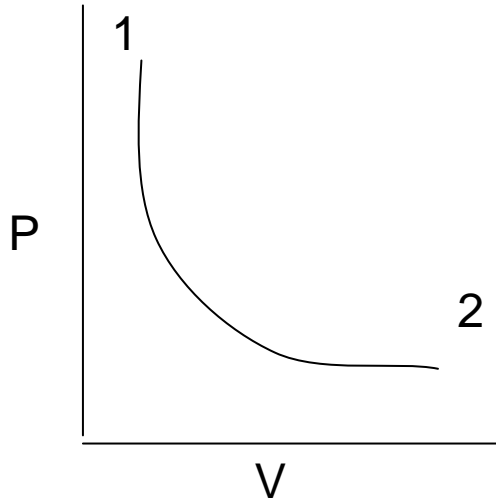

Representation of a reversible process

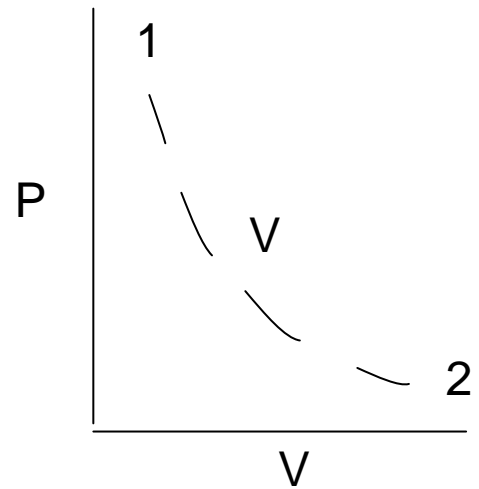

An irreversible process

Quasi - static process (very slow process) :

Quasi - meaning almost, static meaning infinite slowness. Thus quasi-static process is infinitely slow transition of a system. Infinite slowness is the characteristic feature of a quasi-static process. A quasi-static process is a succession of equilibrium states. It is a reversible process.

Cycle: It is a process whose initial and final states are same. Thus at the end of a cycle all the properties of a working fluid have the same values as they had in the initial states.

There are 2 types of cycles. viz. thermodynamic cycle and mechanical cycle.

Thermodynamic cycle:

It is one in which the working substance is re circulated. Ex: water that circulates through steam power plant and refrigerant that passes through refrigeration plant are the examples of thermodynamic cycle. There is change of phase during the process but the end states do not change

Mechanical cycle:

In case of a mechanical cycle the working substance is not re circulated. In an IC engine air and fuel are burnt in the engine, converted into the products of combustion and are then exhausted into the atmosphere. Hence this type of cycle is called mechanical cycle.

Thermodynamic Equilibrium:

The word equilibrium implies a state of balance. In an equilibrium state, there are no unbalanced potentials within the system or driving forces. Thus, a system in equilibrium experiences no changes when it is isolated from its surroundings.

There are many types of equilibrium. A system is not in thermodynamic equilibrium unless the condition of all the relevant types of equilibrium are satisfied, which includes 1) Thermal equilibrium 2) Mechanical equilibrium 3) Phase equilibrium and 4) Chemical equilibrium.

Thermal Equilibrium:

If the temperature is the same throughout the entire system .i.e the system involves no temperature differential which is the driving force or heat flow then we say system is in thermal equilibrium.

Mechanical equilibrium:

It is related to pressure, velocity. A system is in mechanical equilibrium if there is no change in pressure, velocity, specific volume at any point of the system with respect to time. However the pressure may vary within the system with elevation as well as resultant of gravitational effects. However there should not be any imbalance of forces. Then we say the system is in mechanical equilibrium

Phase equilibrium:

If a system involves two phases it is in phase equilibrium when the mass of each phase reaches equilibrium level and stays there.

Chemical equilibrium:

If the systems chemical composition does not change with time, i.e., no chemical reaction occur then we say the system is in chemical equilibrium.

Thus if all thermal, mechanical, phase and chemical equilibrium exist for a system then we say the system exist in thermodynamic equilibrium

Diathermic wall:

A wall which is impermeable to the flow of heat is an adiabatic wall, whereas a wall which permits the flow of heat is a diathermic wall. Thus heat flow takes place through this wall.

Zerth law of Thermodynamics:

It states that when two bodies have equality of temperature with the third body, they in turn have equality of temperature with each other.

When a body A is in thermal equilibrium with body B and also separately with body C then B and C will be in thermal equilibrium with each other.

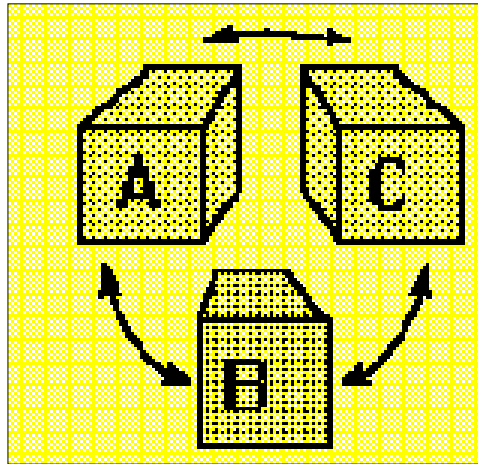

Equality of temperature – Zeroth law of Thermodynamics.

Temperature scales:

Two scales are commonly used for measurement of temperature namely, Fahrenheit after Gabriel Fahrenheit (1686-1736) and Celsius. The Celsius scale was formerly called the centigrade scale but is now designated the Celsius scale after Anders Celsius (1701-1744), the Swedish astronomer who devised this scale.

In SI units of temperature scale we use absolute temperature scale or absolute scale of temperature which comes from second law of thermodynamics and its unit is Kelvin.

Table: Thermometers and Thermometric Properties

Thermometer	Thermometric property	Symbol
Constant volume gas thermometer	Pressure	P
Constant pressure gas thermometer	Volume	V
Electrical Resistance thermometer	Resistance	R
Thermocouple	Thermal e.m.f.	e
Mercury in glass thermometer	Length	L

The absolute scale is related the Celsius scale is the Kelvin scale after William Thompson, 1824-1907, who is also known as Lord Kelvin and is designated K. The relation is $K = ^\circ C + 273.15$

In 1967 the CGPM defined the Kelvin as $1/273.16$ of the temperature at the triple point of water.

In order to obtain a quantitative measure of temperature a reference body is used, and a certain physical characteristic of this body which changes with temperature is selected. The changes in the selected characteristic may be taken as an indication of change in temperature. The selected characteristic is called the thermometric property and the reference body which is used in the determination of temperature is called the thermometer.

A Very common thermometer consists of a small amount of Mercury in an evacuated capillary tube. In this case the extension of the mercury in the tube is used as the thermometric property.



A common Mercury thermometer



Mercury-in-glass thermometer

Presently temperature of triple point of water which is an easily reproducible state is now the standard fixed point of thermometry.

International practical temperature scale: an international temperature scale was adopted at the seventh general conference on weights and measures held in 1927. It was not to replace the Celsius or ideal gas scales, but to provide a scale that could be easily and rapidly used to calibrate scientific and industrial instruments.

International practical scale agrees with Celsius scale at the defining fixed points listed in following table.

Table: Temperature of Fixed Points

	Temperature in °C
Normal boiling point of oxygen	-182.97
Triple point of water (standard)	+0.01
Normal boiling point of water	100.0
Normal boiling point of sulphur	444.60
Normal melting point antimony	630.50
Normal melting point of silver	960.80
Normal melting point of gold	1063.0

Numerical Examples with Solutions:

1) A tank contains mixture of 20kg of nitrogen and 20 kg of carbon monoxide. The total tank volume is 20m³. Determine the density and specific volume of the mixture.

Solution:

Total mass of the mixture: 20 kg N₂ + 20 kg CO = 40 kg mixture

Specific volume = volume / mass = 20 m³ / 40kg = 0.5 m³/kg

Density of mixture = mass / volume = 1/sp. vol = 1/ 0.5 = 2 kg / m³. **Ans.**

2) An automobile has a 1200 kg mass and is accelerated to 7m/s². Determine the force required to perform this acceleration.

Solution:

Force required $F = m * a = 1200 * 7 = 8400 \text{ kg m /s}^2 = 8400 \text{ N}$. **Ans.**

3) The emf in a thermocouple with the test junction at $t^{\circ}\text{C}$ on gas thermometer scale and reference junction at ice point is given by $e = 0.20 t - 5 \times 10^{-4} t^2$ mV. The milli voltmeter is calibrated at ice and steam points. What will this thermometer read in a place where gas thermometer reads 50°C ?

Solution:

At ice point, when $t = 0^{\circ}\text{C}$, $e = 0$ mV.

At steam point, when $t = 100^{\circ}\text{C}$, $e = 0.20 \times 100 - 5 \times 10^{-4} \times (100)^2 = 15$ mV

At $t = 50^{\circ}\text{C}$, $e = 0.20 \times 50 - 5 \times 10^{-4} \times (50)^2 = 8.75$ mV

When the gas thermometer reads 50°C , the thermocouple will read

$$t = 100/15 \times 8.75 \text{ or } 58.33^{\circ}\text{C}.$$

Ans.

4) A barometer to measure absolute pressure shows a mercury column height of 725mm. The temperature is such that the density of the mercury is 13550 kg/m^3 . Find the ambient pressure.

Solution:

Ambient pressure = $\rho \times g \times h = 13550 \times 9.81 \times 725 / 1000 = 96371 \text{ Pa}$

or **P = 0.9637 bar.**

Ans.

5) The temperature t on a Celsius thermometric scale is defined in terms of a property p by the relation $p = e^{(t-B)/A}$, where A and B are constants. Experiment gives values of p of 1.86 and 6.81 at the ice and steam point respectively. Obtain relation for t and also find the temperature t for the reading of $p = 2.5$

Solution:

At ice point, $t = 0^{\circ}\text{C}$, $p = 1.86$ Hence $1.86 = e^{(0-B)/A}$

$$1.86 = e^{-B/A} \text{ or } e^{B/A} = 1/1.86 \text{ and } \ln e^{B/A} = \ln 1/1.86$$

$$\mathbf{B/A = -0.62058 \text{ ----- (1)}}$$

At steam point, $t = 100^{\circ}\text{C}$, $p = 6.81$ $6.81 = e^{(100-B)/A}$

$$\ln 6.81 = (100 - B) / A = 1.9184$$

$$\mathbf{1.9184 A + B = 100 \text{ ----- (2)}}$$

Solving equations (1) and (2)

$$A = 77.05 \text{ and } B = -47.81 \text{ hence } p = e^{[t - (-47.81)] / 77.05}$$

$$\text{The temperature at } p=2.5, \quad 2.5 = e^{(t+47.81)/77.05}$$

$$\ln 2.5 = (t + 47.81) / 77.05 \quad \text{or } t + 47.81 = 0.9163 \cdot 77.05$$

$$\text{or } \quad \mathbf{t = 22.79 \text{ }^\circ\text{C}}$$

Ans.

6) A hiker is carrying a barometer that measures 101.3 kPa at the base of the mountain. The barometer reads 85 kPa at the top of the mountain. The average air density is 1.21 kg/m³. Determine the height of the mountain.

Solution:

Pressure at the base of the mountain = $\rho_1 \cdot g \cdot h_1$.

$$h_1 = p / (\rho_1 \cdot g) = 101.3 \cdot 1000 / (9.81 \cdot 1.21) = 8534 \text{ m.}$$

Also at the top of the mountain $p = \rho_2 \cdot g \cdot h_2$.

$$h_2 = p / (\rho_2 \cdot g) = 85 \cdot 1000 / (9.81 \cdot 1.21) = 7161 \text{ m.}$$

$$\text{Hence the height of the mountain} = h_1 - h_2 = 8534 - 7161 = \mathbf{1373 \text{ m.}}$$

Ans.

7) A lunar excursion module (LEM) weighs 1500 kgf at sea level; on earth. What will be its weight on the surface of the moon, where $g = 1.7 \text{ m/s}^2$? On the surface of the moon, what will be the force in kgf required to accelerate the module at 10 m/s^2 ?

Solution:

The mass m of the LEM is given by $W = mg/g_0$

$$1500 \text{ kgf} = m \cdot \{ (9.806 \text{ m/s}^2) / (9.806 \text{ kg/kgf} \cdot \text{m/s}^2) \}$$

$$\text{i.e. } m = 1500 \text{ kg}$$

The weight of the LEM on the moon would be

$$\mathbf{W = 1500 \text{ kg} \cdot \{ (1.7 \text{ m/s}^2) / (9.806 \text{ kg/kgf} \cdot \text{m/s}^2) \}}$$

Ans.

The force required to accelerate the module at 10 m/s^2

$$= [1500 \text{ kg} / (9.806 \text{ kg/kgf} \cdot \text{m/s}^2)] \cdot 10 \text{ m/s}^2 = \mathbf{1530 \text{ kgf}}$$

Ans.

8) A cannon ball of 5 kg acts on a piston in a cylinder of 0.15 m diameter. As the gunpowder is burnt, a pressure of 7 MPa is created in the gas behind the ball. What is the acceleration of the ball if the cylinder is pointing horizontally?

Solution:

Mass of the cannon ball = 5 kg

Diameter of the cylinder = 0.15 m

$$\mathbf{\text{Force} = \text{Area} \cdot \text{Pressure} = (\pi / 4) \cdot (0.15)^2 \cdot 7 \cdot 10^6 = 123716.25 \text{ N}}$$

Ans.

$$\mathbf{F = m \cdot a \quad \text{Hence } a = F / m = 123716.25 / 5 = 24743.25 \text{ m/s}^2}$$

Ans.

Module 2

WORK & HEAT

Mechanics definition of work: Work is done when the point of application of a force moves in the direction of the force. The amount of work is equal to the product of the force and the distance through which the point of application moves in the direction of the force. i.e., work is identified only when a force moves its point of application through an observable distance.

Mathematically, $W = \int_1^2 F \cdot dx$

However, when treating thermodynamics from a macroscopic point of view, it is advantageous to tie in the definition work with the concepts of systems, properties and processes.

Thermodynamic definition of work: It is a kind of interaction that would occur at the system boundaries. It can be positive or negative.

Definition of Positive work is said to be done by a system when the 'sole effect' external to the system could be reduced to the raising of a weight.

Comments: The word 'sole effect' indicates that the raising of weight should be the only interaction between the system and surroundings in order to say that there is work interaction between the system and the surroundings. The phrase 'external to the system' indicates that the work is a boundary phenomenon. The magnitude of work interaction depends upon the system boundary. This is illustrated with an example.

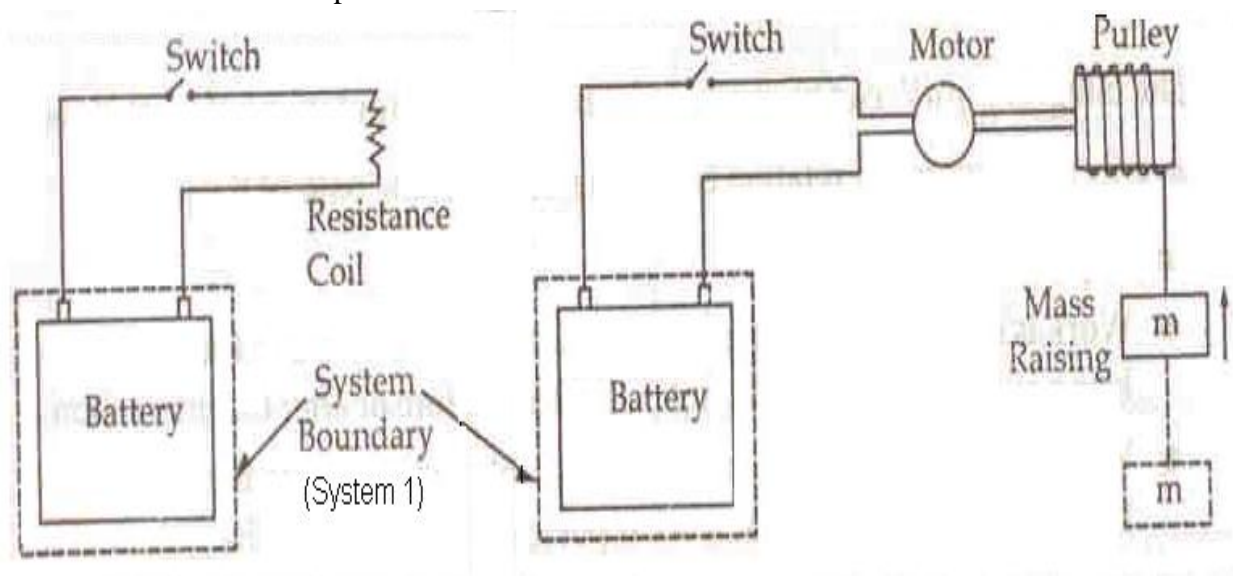

Figure 1: Equivalence of Current Work Interaction between the System and the Surroundings

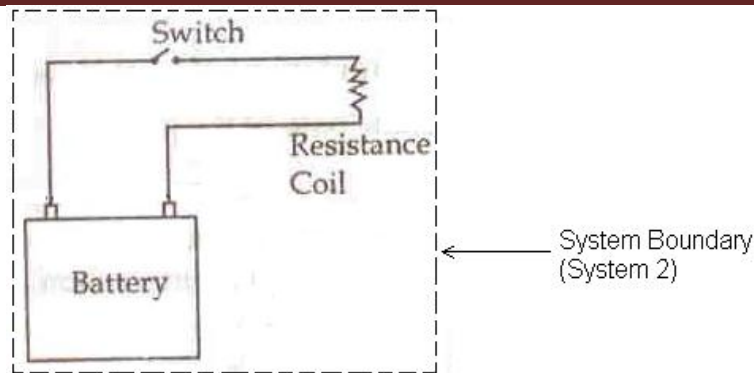

Figure 2: System Comprising of Battery, Switch & Resistance Coil

For the two systems shown in figure, system (1) comprising battery alone has work interaction with the surroundings, whereas for system (2) which includes motor, weights etc along with the battery, the work interaction is zero.

The word 'could be reduced to' indicates that it is not necessary that weights should actually be raised in order to say that there is work interaction between the system and the surroundings. It is just sufficient to have an effect which is equivalent to the raising of weight.

Here an electrical storage battery constitutes system 1 whose terminals are connected to an electrical resistance coil through a switch. The circuit external to the battery constitutes the surroundings. When the switch is closed, the current flow through the coil, and the resistance (surroundings) become warmer and the charge of the battery (system) decreases. Obviously there has been interaction between the system and the surroundings. According to mechanics this interaction cannot be classified as work because there has been no action of force through a distance or of torque through an angle. However, as per thermodynamics concepts, the battery (system) does work as the electrical energy crosses the system boundary. Further, the electrical resistance can be replaced by an ideal frictionless motor pulley arrangement which can wind a string and thereby raise suspended weight. The sole effect, external to the system, is raising of a weight. As such interaction of battery with resistance coil is a work.

Sign Conventions for work:

Work is said to be positive, if it is done by the system on the surroundings

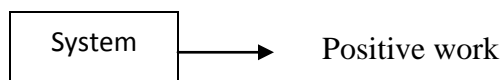

Work is said to be negative, if it is done on the system by the surroundings

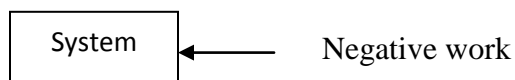

$$\text{Therefore, } W_{\text{system}} + W_{\text{surroundings}} = \text{Zero}$$

The unit of work is N-m or Joule. The rate at which work is done by, or upon, the system is known as power. The unit of power is J/s or watt.

Work is one of the forms in which a system and its surroundings can interact with each other. There are various types of work transfer which can get involved between them.

Work done at the moving boundary of a system (Expression for displacement work)

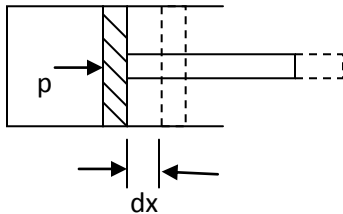

Consider a piston-cylinder arrangement which contains certain working fluid undergoing quasi-static process.

Let p = Pressure exerted by the fluid on the piston

A = Area of c/s of the cylinder

dx = displacement of the piston when the system has undergone an infinitesimal change of state.

∴ Displacement work: dw = Force x displacement

$$= p.A \times dx$$

$$\text{i.e., } dw = p.dV$$

Where dv is the infinitesimal change in volume of the system. If the system undergoes a finite change of state from state (1) to state (2). Then the displacement work is given by

$$\int_1^2 dw = \int_1^2 p.dV$$

The integration of above equation can be done only if the relationship between P and v during the process is known i.e., if the path of the process is well defined. Hence, work is a path function. As work depends on the path of the process which it follows, there will be different values of work for different process between two given states. Hence the differentials of the path functions are in exact differentials. The symbol δ will be used to designate inexact differentials. The magnitude of the work transfer by the system during the process from state (1) to state (2) containing unit mass of the fluid will be written as, $\int_1^2 \delta w = W_1 W_2$ or W_{1-2} .

The process can be represented by a full line on an appropriate thermodynamic coordinate system (in this case p - V diagram) and the area under the curve gives the work done by the system during the process.

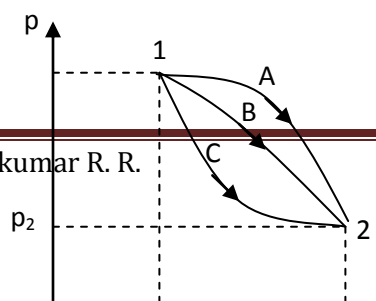

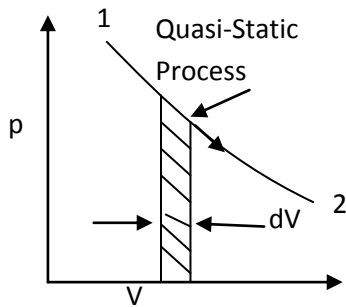

Quasi-Static pdV work

Work-a path function

Inspection of the pV diagram above shows that just by specifying the end states 1 and 2 does not determine the area (or work); the nature of the curve needs to be known. The curve may be arched upwards or it may sag downwards, and the area under the curve will vary accordingly. For the same initial and final states, the work done by the system in following the paths A, B and C are different. Therefore the work is a path function and not a point function. Accordingly the work transfer across the system boundaries is not classified as a thermodynamic property.

The expression $\delta w = pdV$ holds good under the following restrictions

- i) The system is closed
- ii) There is no friction within the system
- iii) The pressure and all other properties are the same on all the boundaries of the system
- iv) The system is not influenced by motion, gravity, capillarity, electricity and magnetism

Expression for Displacement work for various Quasi-Static Processes (pdV work):

1. Constant volume process: (Isochoric Process).

For a constant volume process i.e., $V = \text{constant}$ ($dV = 0$) as represented in the p-V diagram below.

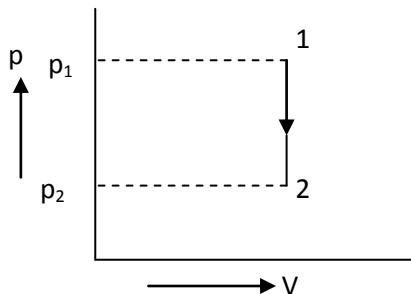

$$W_{1-2} = \int_1^2 p \cdot dV \quad \text{but } dV = 0$$

$\therefore (W_d)_{1-2} = 0$

2. Constant pressure process: (Isobaric process).

For a closed system undergo a constant pressure process from state 1 (volume V_1 and pressure p_1) to a final state 2 (volume V_2). The process is represented in the p-V diagram as shown below.

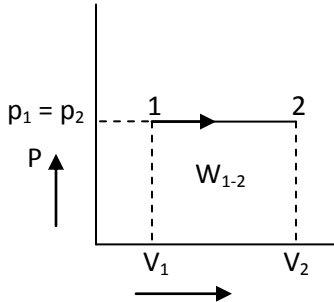

$$W_{1-2} = \int_1^2 p \cdot dV, \text{ where } p = \text{constant}$$

$$\therefore W_{1-2} = p \int_1^2 dV = p (V_2 - V_1)$$

$$\therefore (W_d)_{1-2} = p (V_2 - V_1)$$

3. Hyperbolic process i.e., $pV = \text{constant}$:

The hyperbolic expansion process from state 1 to state 2 is represented on a p-V diagram as shown below.

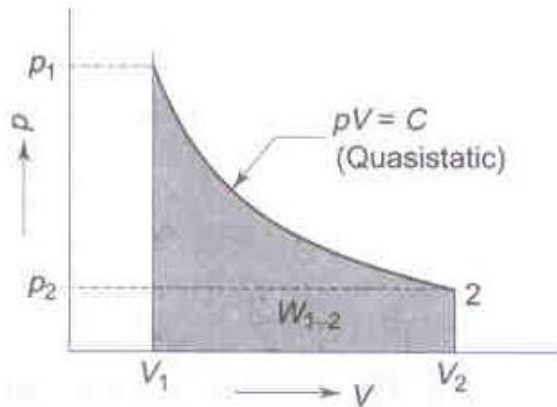

Process in which $pV = \text{Constant}$

$$W_{1-2} = \int_1^2 p \cdot dV$$

But $pV = \text{constant}$ i.e., $pV = p_1V_1$, $\therefore p = \frac{p_1V_1}{V}$

$$\therefore W_{1-2} = \int_1^2 p \cdot dV$$

$$= \int_1^2 \frac{p_1 V_1}{V} .dV = p_1 V_1 \int_1^2 \frac{dV}{V}$$

$$= p_1 V_1 [\ln V_2 - \ln V_1]$$

where p_1 = Initial pressure of the system

V_1 = Initial volume of the system

p_2 = Final pressure of the system

V_2 = Final volume of the system

$$\text{i.e., } (W_d)_{1-2} = p_1 V_1 \ln \frac{V_2}{V_1}$$

4. Polytropic process, i.e., $pV^n = \text{constant}$

A polytropic process is represented on a p-V diagram as shown below.

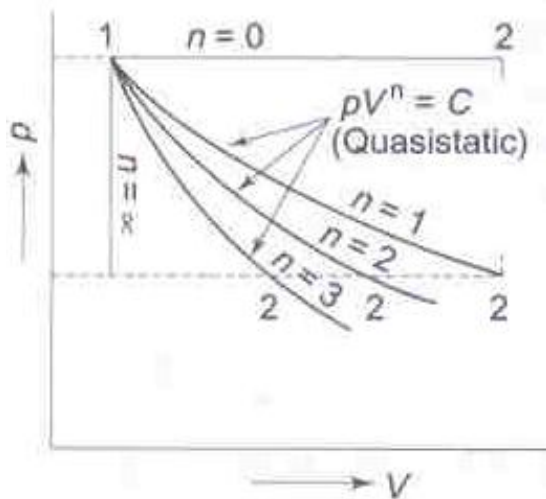

Figure: Process in which $pV^n = \text{Constant}$

$$W_{1-2} = \int_1^2 p .dV$$

$$\text{But } pV^n = \text{constant} \quad \text{i.e., } pV^n = p_1 V_1^n = p_2 V_2^n \quad \therefore p = \frac{p_1 V_1^n}{V^n}$$

$$\therefore W_{1-2} = \int_1^2 \frac{p_1 V_1^n}{V^n} .dV$$

$$= p_1 V_1^n \int_1^2 V^{-n} .dV$$

$$= p_1 V_1^n \left[\frac{V^{-n+1}}{-n+1} \right]_1^2 = \frac{p_1 V_1^n}{1-n} [V_2^{1-n} - V_1^{1-n}]$$

$$= \frac{p_1 V_1^n .V_2^{1-n} - p_1 V_1}{1-n} \quad \text{but } p_1 V_1^n = p_2 V_2^n$$

$$= \frac{p_2 V_2 - p_1 V_1}{1-n}$$

$$\therefore (W_d)_{1-2} = \frac{p_1 V_1 - p_2 V_2}{n-1}$$

Where 'n' is called the index of expansion or compression

Note: 1. Work is a transient phenomenon i.e., it is present only during a process. Mathematically speaking, work is a path function.

$$\begin{aligned} \therefore \int_1^2 dw &= w_2 - w_1 \text{ is wrong} \\ &= w_{1-2} \text{ i.e., } \delta w \text{ is inexact differentials.} \end{aligned}$$

2. For irreversible process $\delta w \neq \int_1^2 P.dv$

Other Types of Work Transfer

1. Shaft Work:

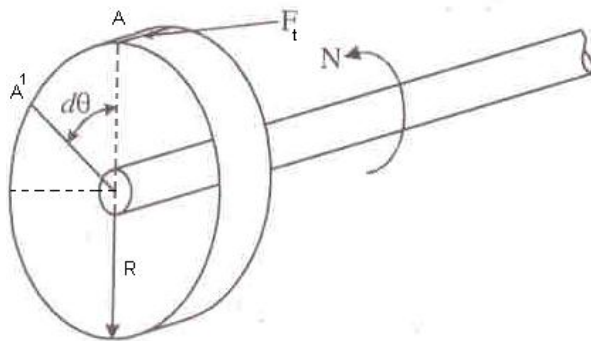

Shaft work

Let F_t = Tangential force on the shaft

R = Radius of the shaft

$d\theta$ = Angular displacement of the shaft in an interval of time 'dt'

$$\begin{aligned} \therefore \text{Shaft work in time interval 'dt', is } dW_s &= F_t \cdot AA^1 \\ &= F_t \cdot R \cdot d\theta \end{aligned}$$

$$\text{i.e., } W_s = T \cdot d\theta$$

$$\therefore \text{Work done / unit time} = \frac{dW_s}{dt} = T \cdot \frac{d\theta}{dt} = T \cdot \omega \quad \text{where } \omega = \text{angular velocity, } T = \text{Torque}$$

$$\text{But } \omega = \frac{2\pi N}{60} \quad \text{where } N = \text{rpm of the shaft}$$

$$\therefore \text{Shaft work, } W_s = \frac{2\pi NT}{60} \text{ watts}$$

2. Stirring Work: Stirring work is nothing but shaft work is done on the system by using a stirrer which is driven by a shaft.

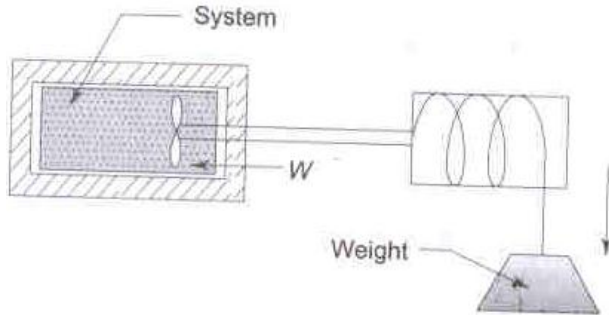

Figure3: Paddle-wheel work

As the weight is lowered, and the paddle wheel turns, there is work transfer into the system which gets stirred. Since the volume of the system remains constant, $\int p dv = 0$. If m is the mass of the weight lowered through a distance dz and T is the torque transmitted by the shaft in rotating through an angle $d\theta$, the differential work transfer to the fluid is given by

$$\delta w = mgdz = Td\theta$$

$$\text{and the total work transfer is } w = \int_1^2 mgdz = \int_1^2 W^1 dz = \int_1^2 Td\theta \quad \text{where } W^1 \text{ is the weight lowered}$$

3. Electrical Work: When a current flows through a resistor, taken as system, there is work transfer into the system. This is because the current can drive a motor, the motor can drive a pulley and the pulley can raise a weight.

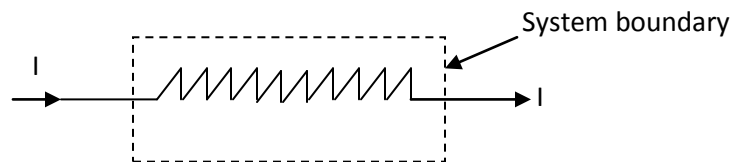

The current I , flows is given by,

$$I = \frac{dC}{d\tau} \quad \text{where } C = \text{charge in coulombs}$$

$$\tau = \text{time in seconds}$$

Thus dC is the charge crossing a system boundary during time $d\tau$. If E is the voltage potential, the work is $\delta w = E.dC$

$$= EI d\tau$$

$$\therefore w = \int_1^2 EI d\tau$$

$$\therefore \text{The electrical work is, } w = \lim_{\delta\tau \rightarrow 0} \frac{dw}{d\tau} = EI$$

This is the rate at which work is transferred.

4. Work done in stretching a wire: Consider a wire as the system. If the length of the wire in which there is a tension T is changed from L to $L + dL$, the infinitesimal amount of work that is done is equal to, $\delta w = -T dL$

The -ve sign is used because a positive value of dL means an expansion of the wire, for which work must be done on the wire i.e., negative work.

$$\text{For a finite change of length, } w = -\int_1^2 T dL$$

Within the elastic limits, if E is the modulus of the elasticity, σ is the stress, ϵ is the strain, and A is the cross sectional area, then

$$T = \sigma A = E.\epsilon.A$$

$$\text{Therefore } \delta w = -E.\epsilon.AdL$$

$$\text{But } d\epsilon = dL/L \text{ or } dL = L \times d\epsilon$$

$$\therefore \delta w = -T dL = -E.\epsilon.A. L d\epsilon$$

$$\begin{aligned} \text{i.e., } w &= -EAL \int_1^2 \epsilon d\epsilon \\ &= -\frac{A\epsilon L}{2} (\epsilon_2^2 - \epsilon_1^2) \end{aligned}$$

5. Work done in changing the area of a surface film: A film on the surface of a liquid has a surface tension which is a property of the liquid and the surroundings. The surface tension acts to make the surface area of the liquid a minimum. It has the unit of force per unit length.

The work done on a homogeneous liquid film in changing its surface area by an infinitesimal amount dA is

$$\delta w = -\sigma dA \quad \text{when } \sigma = \text{surface tension (N/m)}$$

$$\therefore w = -\int_1^2 \sigma dA$$

6. Magnetization of a paramagnetic field: The work done per unit volume on a magnetic material through which the magnetic and magnetization fields are uniform is,

$$\delta w = -H.dI$$

$$\text{i.e., } w = -\int_1^2 H.dI$$

Where H = field strength

I = Component of the magnetization field in the direction of the field.

-ve sign provides that an increase in magnetization (+ve dI) involves -ve work.

Note: It may be noted in the above expressions that the work is equal to the integral of the product of an intensive property and the change in its related extensive property. These expressions are valid only for infinitesimally slow quasi-static process.

Network Transfer: The network interaction between the system and the surroundings for any process will be the algebraic sum of all types of work interaction that has taken place between the system and the surroundings.

Therefore if W_{1-2} represents the net work transfer then,

$$W_{1-2} = (W_d)_{1-2} \pm (W_s)_{1-2} \pm (W_e)_{1-2} \pm (W_{\text{mag}})_{1-2} \pm \dots$$

+ve sign has to be used when the work transfer takes place from the system to the surroundings and –ve sign to be used when work transfer is from the surroundings to the system.

Heat: Heat is a mode of energy transfer that takes place between the system and the surroundings solely due to the temperature difference. Thus, heat is a transient phenomenon. It can be recognized only during a process. It is not a thermodynamic property of the system. Like work, heat is a path function i.e., the magnitude of heat transfer between the system and surroundings depends upon the type of process the system is undergoing.

Heat transfer always takes place from a region of higher temperature to a region of low temperature. The magnitude of the heat transfer into unit mass of the fluid in the system during a process from state (1) to state (2) will be written as $\int_1^2 \delta q = q_2$ or q_{1-2} and not as $\int_1^2 \delta q = q_1 - q_2$. $\int_1^2 \delta q$ represents the total heat transfer that takes place when the system undergoes a change of state from state 1 to state 2.

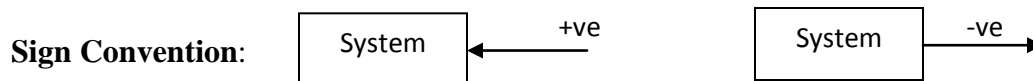

Heat transfer is considered as positive if it takes place from the surroundings to the system and it is considered as negative if it takes place from the system to the surroundings.

During an adiabatic process, $Q = 0$

Units: Since heat is a form of energy transfer it will have the same units as that of energy. In SI units it is expressed in Joules (J) or Kilo Joules (kJ).

Comparison between work and heat:

Similarities:

- Both are path functions and inexact differentials.

- Both are boundary phenomenon i.e., both are recognized at the boundaries of the system as they cross them.
- Both represent transient phenomenon; these energy interactions occur only when a system undergoes change of state i.e., both are associated with a process, not a state. Unlike properties, work or heat has no meaning at a state.
- A system possesses energy, but not work or heat.
- Concepts of heat and work are associated not with a ‘store’ but with a ‘process’.

Dissimilarities:

- Heat is energy interaction due to temperature difference only; work is by reasons other than temperature difference.
- In a stable system, there cannot be work transfer; however there is no restriction for the transfer of heat.
- The sole effect external to the system could be reduced to rise of a weight but in the case of a heat transfer other effects are also observed.
- Heat is a low grade energy whereas work is a high grade energy.

Problems:

1. Evaluate the work done in the following processes. The systems to be considered are underlined.

- a) An agent slowly raises a body of mass 2 kg a distance of 3 mts in a gravitational field of standard acceleration.

Solution: By definition, considering agent as the system, it does positive work. The magnitude of work is measured by the product of the weight its lifts and the distance through which it is lifted.

$$W = + mg \cdot l = 2 \times 9.81 \times 3 = + 58.86 \text{ J}$$

$$\therefore \text{Work done by the agent} = + 58.86 \text{ J}$$

Because, work is done by the agent, work is done on the body to the same amount.

$$\therefore \text{Work done on the body} = 58.86 \text{ J}$$

$$\text{or Work done by the body} = - 58.86 \text{ J}$$

- b) A mass of 1 tonne is suspended from a pulley block. An agent slowly raises the mass against the standard gravitational acceleration by 2m.

Solution: By definition, considering agent as the system, it does positive work.

$$\therefore W = + mg \cdot l = 1000 \times 9.81 \times 2 = 19620 \text{ J} = 19.62 \text{ kJ}$$

$$\therefore \text{Work done by the agent} = 19.62 \text{ kJ}$$

Because, work is done by the agent, work is done on the mass to the same amount.

∴ Work done on the mass = 19.62 kJ
 or Work done by the mass = - 19.62 kJ

- c) After raising the mass as in (b), the mass falls freely through the same vertical distance of 2 m. The drag force of the atmosphere on the body is 50 N.

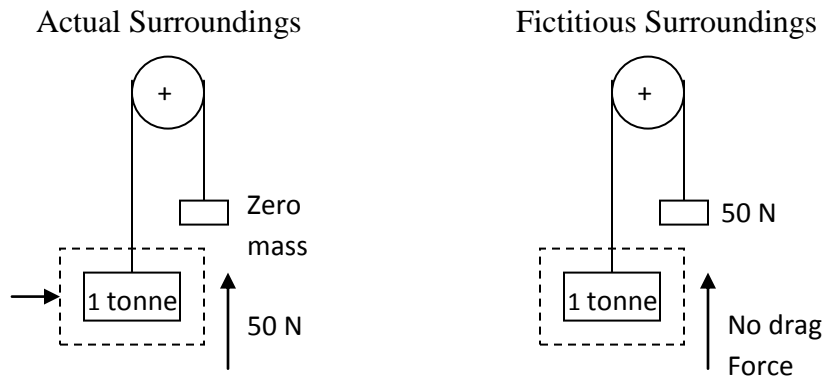

Solution: Considering mass as a system (w r t. fictitious surroundings)

$W = F \times l = 50 \times 30 = 1500 \text{ J} = 1.5 \text{ kJ}$
 ∴ Work done by the mass = 1.5 kJ
 Work done by the atmosphere = - 1.5 kJ
 Or Work done on the atmosphere = 1.5 kJ

- d) A body of mass 15 kg falls freely in a vacuum through a vertical distance of 30m. The gravitational acceleration is 6 m/s^2 .

e)

Solution: Considering body as a system, as it is falling freely there is no interaction with the system boundary and hence work done by the body is zero. (In other words, the work done by the body is zero as it can lift no weight. All that is happening as the body is falling freely is that its PE is decreasing and its KE is increasing accordingly).

- f) A rat weighing 5.0 N climbs a stair 0.2 m in height.

Solution: $W_{\text{rat}} = 0$ (since there is no interaction between the system and its surroundings).

2. Indicate in the following cases, the heat exchange and work exchange are positive, negative or zero, and why

- a) A copper block of 1 kg heated to 100° C is dipped into water at 15° C . Consider copper as system.

Ans: $\delta W = 0$, δQ is negative

b) Heat is added to a *gas* in a rigid container such that pressure and temperature increases.

Consider gas as system,

Ans: $\delta W = 0$, δQ is positive.

c) *Gas* from a bottle is used to inflate a balloon which is originally flat. Consider gas as system.

Ans: δW is Positive, $\delta Q = 0$

d) An insulated *wire* is stretched. Consider wire as a system.

Ans: δW is negative, $\delta Q = 0$

e) A mouse climbs 20 steps of a stair case. Consider mouse as the system.

Ans: $\delta Q = \delta W = 0$

f) *Gas* in an insulated cylinder expands as the piston is slowly moved outwards.

Ans: $\delta Q = 0$, δW is positive

g) A closed rigid vessel containing steam at a temperature of 200°C is left standing in an atmosphere which is at 20°C . Consider steam as the system.

Ans: For a closed rigid vessel, there is no change in volume and accordingly work done is zero. i.e., $\delta W = 0$. Since the steam is at a temperature higher than that of the surrounding atmosphere, the heat is rejected to the atmosphere. i.e., heat interaction is negative or δQ is negative.

h) The air in a *tyre* and connecting pump the pump plunger is pushed down, forcing air into the tyre. The tyre, pump walls and connecting tube can be thought of to be non-conducting. Consider air as a system.

Ans: δW is negative and $\delta Q = 0$

i) An electric current flows steadily through a *resistor* which is immersed in running water.

Ans: Considering resistor as system, current flows through the resistance i.e., electrical work is done on the system $\therefore \delta W_e$ is negative

Due to the flow of current the resistor gets heated up resulting in heat transfer to the surrounding cold water from the resistor.

$\therefore \delta Q$ is negative (heat transfer from the system)

j) A *container* with rigid non-conducting walls holds a complete electrical circuit consisting of a heating element and charged storage battery. The temperature and pressure of the air in the container increases.

Ans: No interaction taking place across the boundary. The system boundary does not move as the walls are rigid. $\therefore \delta W = 0$

The walls are non-conducting \therefore though the temperature inside the system increase, no heat transfer to the surroundings can take place $\therefore \delta Q = 0$

k) 0.1 kg of *gas* contained in an insulated cylinder expands moving the piston slowly outwards

Ans: The cylinder is insulated \therefore No. heat transfer is possible $\therefore \delta Q = 0$

The gas expands \therefore the system boundary expands $\therefore \delta W_d$ is positive

Problems:

3. Gas from a bottle of compressed helium is used to inflate a balloon originally folded completely flat, to a volume of 0.25 m^3 . If the barometer reads 760 mm of mercury, how much work is done by the system comprising the helium initially in the bottle, if the balloon is light and requires no stretching. Sketch the system before and after the process.

Solution:

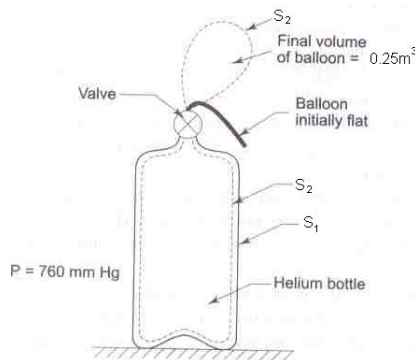

The firm line S_1 shows the boundary of the system before the process, and the dotted line S_2 shows the boundary after the process.

Total displacement work is given by

$$(W_d)_{1-2} = (W_d)_{\text{bottle portion of the system}} + (W_d)_{\text{Balloon portion of the system}}$$

Since there is no displacement of the bottle portion of the system boundary, it follows that $(W_d)_{\text{bottle}} = 0$

$$= 0 + (W_d)_{\text{Balloon}}$$

The balloon is expanding against a constant atmosphere pressure of 760 mm of mercury,

i.e., $p = wh$

$$= 9810 (13.6) 0.76 = 1.01396 \times 10^5 \text{ N/m}^2 = 101.396 \text{ kPa}$$

$$\begin{aligned} \therefore (W_d)_{\text{balloon}} &= \int p dV = p \int_1^2 dV \\ &= p (V_2 - V_1) \\ &= 101.396 (0.25 - 0) \\ &= 25.349 \text{ kJ} \end{aligned}$$

4. Determine the work done by the air which enters an evacuated bottle from the atmosphere when the cork is opened, atmospheric air rushes into it. If the atmospheric pressure is 101.396 kPa and 0.6 m^3 of air (measured at atmosphere conditions) enters the bottle.

Solution:

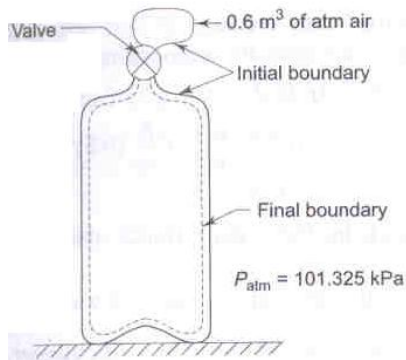

No work is done by the part of the boundary in contact with the bottle. Work is done only by the moving part external to the bottle. The pressure over this moving part is uniform at 101.396 kPa

∴ Displacement work done by the system,

$$\begin{aligned} W_d &= (W_d)_{\text{bottle}} + (W_d)_{\text{atmosphere}} \\ &= 0 + \int_1^2 p \cdot dV \\ &= p (V_2 - V_1) = 101.396 (0 - 0.6) \\ &= - 60.8 \text{ kJ} \end{aligned}$$

Negative, because the boundary is contracting. Thus the surroundings do positive work at the boundary and the work done by the air negative

5. A spherical balloon has a diameter of 25 cm and contains air at a pressure of $1.5 \times 10^5 \text{ Pa}$. The diameter of the balloon increases to 30 cm in a certain process and during this process the pressure is proportional to the diameter. Calculate the work done by the air inside the balloon during this process.

Solution:

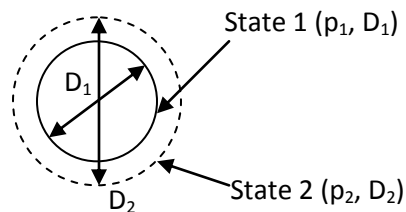

$$D_1 = 0.25 \text{ m}, D_2 = 0.3 \text{ m},$$

$$p \propto D,$$

$$p_1 = 1.5 \times 10^5 \text{ N/m}^2$$

$$\text{We have } W_{1-2} = \int_1^2 p \cdot dV \quad \text{--- (1)}$$

$$\text{But, volume of sphere} = V = \frac{\pi D^3}{6}$$

$$\therefore dV = \frac{\pi}{6} \cdot 3D^2 \cdot dD$$

Also, $p \propto D$ i.e., $\frac{p}{D} = \text{constant} = K$

$$\therefore \frac{p}{D} = \frac{p_1}{D_1} = \frac{p_2}{D_2} \quad \therefore p = \frac{p_1}{D_1} \cdot D$$

Equation (1) becomes, $W_{1-2} = \int_1^2 \frac{p_1}{D_1} \cdot D \cdot \frac{\pi}{6} 3D^2 \cdot dD$

$$= \frac{\pi}{2} \cdot \frac{p_1}{D_1} \int_1^2 D^3 = \frac{\pi}{2} \frac{p_1}{D_1} \left[\frac{D^4}{4} \right]_1^2$$

$$= \frac{\pi}{2} \cdot \frac{p_1}{D_1} \left[\frac{D_2^4 - D_1^4}{4} \right]$$

$$= \frac{\pi}{2} \cdot \frac{1.5 \times 10^5}{0.25} \left[\frac{0.3^4 - 0.25^4}{4} \right]$$

$$W_{1-2} = 988.13 \text{ J}$$

Positive sign indicates that work is done by the system.

6. Gas from a bottle of compressed helium is used to inflate an inelastic flexible balloon, originally folded completely flat to a volume of 0.5 m^3 . If the barometer reads 760 mm of Hg, what is the amount of work done upon the atmosphere by the balloon (50.66 kJ)
7. When the valve of the evacuated bottle is opened, atmosphere air rushes into it. If the atmosphere pressure is 101.325 KPa, and 1.2 m^3 of air (measured at atmosphere conditions) enters the bottle, calculate the work done by the air (-60.8 kJ).
8. A gas system, confined by a piston and cylinder, undergoes a change of state such that the product of pressure and volume remains constant. If the process begins at a pressure of 3 bar and a volume 0.015 m^3 and proceeds until the pressure falls to half its initial value, determine the magnitude and direction of the work flow.

Solution:

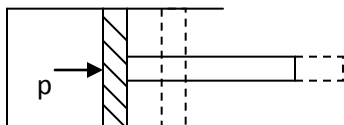

$pV = C$ i.e., hyperbolic process or $p_1 V_1 = p_2 V_2$

Given, $p_1 = 3 \times 10^5 \text{ Pa}$ $V_1 = 0.015 \text{ m}^3$ $p_2 = 1.5 \times 10^5 \text{ m}^3$
 $V_2 = ?$ $W_{1-2} = ?$

We have, $p_1 V_1 = p_2 V_2$ $\therefore V_2 = \frac{p_1 V_1}{p_2} = \frac{3 \times 10^5 \times 0.015}{1.5 \times 10^5} = 0.03 \text{ m}^3$

\therefore Displacement work, $(W_d)_{1-2} = \int_1^2 p \cdot dV = p_1 V_1 \ln \frac{V_2}{V_1}$
 $= 3119.16 \text{ J} = 3.1192 \text{ kJ}$

Positive sign indicates work is done by the system on the surroundings.

9. A certain amount of gas is compressed from 1 bar and 0.1 m^3 to 5 bar and 0.03 m^3 . The process is according to the law $pV^n = K$. Determine the magnitude and direction of work.

Solution: Given: $p_1 = 1 \text{ bar}$; $V_1 = 0.1 \text{ m}^3$; $p_2 = 5 \text{ bar}$; $V_2 = 0.03$

We have for a polytropic process,

Displacement work, $(W_d)_{1-2} = \frac{p_1 V_1 - p_2 V_2}{n - 1}$

To find the compression index n , we have,

$p_1 V_1^n = p_2 V_2^n = C$

i.e., $\frac{p_1}{p_2} = \left(\frac{V_2}{V_1} \right)^n$

Taking log's on both sides we have

$\ln \frac{p_1}{p_2} = n \cdot \ln \frac{V_2}{V_1}$

$\therefore n = \frac{\ln \frac{1}{5}}{\ln \frac{0.03}{0.1}} = 1.34$

$\therefore (W_d)_{1-2} = \frac{1 \times 10^5 (0.1) - 5 \times 10^5 (0.03)}{1.34 - 1} = -14706 \text{ J} = -14.706 \text{ kJ}$

i.e., work done on the gas = 14.706 kJ

10. A gas confined in a cylinder by a piston is at pressure of 3 bar and a volume of 0.015 m^3 . The final pressure is 1.5 bar. Determine the magnitude and direction of work transfer for the following processes. i) $p \propto V$, ii) $p \propto \frac{1}{V}$, iii) $p \propto V^2$ and iv) $p \propto \frac{1}{V^2}$

Solution: Given: $p_1 = 3 \times 10^5 \text{ Pa}$; $V_1 = 0.015 \text{ m}^3$; $p_2 = 1.5 \times 10^5 \text{ Pa}$ $V_2 = ?$ $(W_d) = ?$

i) $p \propto V$ i.e., $\frac{p}{V} = \frac{p_1}{V_1} = C = \frac{p_2}{V_2}$

We have, $(W_d)_{1-2} = \int_1^2 p \cdot dV$

$$\begin{aligned} &= \int_1^2 \frac{p_1 V}{V_1} \cdot dV = \frac{p_1}{V_1} \int_1^2 V \cdot dV \\ &= \frac{p_1}{2V_1} [V_2^2 - V_1^2] \end{aligned}$$

we have $\frac{p_1}{V_1} = \frac{p_2}{V_2} \quad \therefore V_2 = p_2 \frac{V_1}{p_1} = \frac{1.5}{3}(0.015) = 0.0075 \text{ m}^3$

$$\therefore (W_d)_{1-2} = \frac{3 \times 10^5}{2(0.015)} [0.0075^2 - 0.015^2] = -1.688 \text{ kJ}$$

-ve sign indicates that work is done on the system

ii) $p \propto \frac{1}{V} \quad \text{i.e., } pV = C$

Ans: $(W_d)_{1-2} = 3.1192 \text{ kJ}$

iii) $p \propto V^2 \quad \text{i.e., } \frac{p_1}{V_1^2} = \frac{p_2}{V_2^2} = C = \frac{p}{V^2} \quad \therefore V_2 = \sqrt{\frac{p_2 - V_1^2}{p_1}} = 0.0106 \text{ m}^3$

$$(W_d)_{1-2} = \int_1^2 p \cdot dV$$

$$\begin{aligned} &= \int_1^2 \frac{p_1}{V_1^2} V^2 \cdot dV \\ &= \frac{p_1}{V_1^2} \int_1^2 V^2 \cdot dV \\ &= \frac{p_1}{3V_1^2} [V_2^3 - V_1^3] \\ &= \frac{3 \times 10^5}{3(0.015)^2} [0.0106^3 - 0.015^3] = -0.9707 \text{ kJ} \end{aligned}$$

-ve sign indicates that work is done on the system

iv) $p \propto \frac{1}{V^2} \quad \text{i.e., } pV^2 = C = p_1 V_1^2 = p_2 V_2^2$

$$\therefore V_2 = \sqrt{\frac{p_1 V_1^2}{p_2}} = \sqrt{\frac{3 \times 0.015^2}{1.5}} = 0.0212 \text{ m}^3$$

$$\begin{aligned} \text{We have } (W_d)_{1-2} &= \int_1^2 p \cdot dV = \int_1^2 \frac{p_1 V_1^2}{V^2} \cdot dV = p_1 V_1^2 \int_1^2 \frac{1}{V^2} \cdot dV \\ &= p_1 V_1^2 \left[(-2+1)V^{-1} \right]_1^2 \\ &= p_1 V_1^2 \left[-\frac{1}{V} \right]_1^2 \end{aligned}$$

$$= p_1 V_1^2 \left(-\frac{1}{V_2} + \frac{1}{V_1} \right)$$

$$= p_1 V_1^2 \left(\frac{1}{V_1} - \frac{1}{V_2} \right)$$

Substituting the given values, we get $(W_d)_{1-2} = 1.316 \text{ kJ}$

+ve sign indicates that work is done by the system

11. A non-flow reversible process occurs for which $p = 3V^2 + 1/V$ where p is in N/cm^2 and V is in m^3 . What is the work done when V changes from 0.5 m^3 to 1 m^3 .

Solution: We have $(W_d)_{1-2} = \int_1^2 p \cdot dV$

$$= 10^4 \int_1^2 \left(3V^2 + \frac{1}{V} \right) dV$$

$$= \int_1^2 3 V^2 dV + \int_1^2 dV/V$$

$$= 10^4 \left\{ \frac{3}{3} [V_2^3 - V_1^3] + \ln \frac{V_2}{V_1} \right\}$$

$$= 10^4 \left\{ [1^3 - 0.5^3] + \ln \frac{1}{0.5} \right\}$$

$$= 1.568 \times 10^4 \text{ J} = 15.86 \text{ kJ}$$

12. A system consists of a cylinder and piston machine. The external normal load applied to the piston is given by $F = -7000 + 15000L$ Newton's, where L is the distance in mts from the closed end of the cylinder to the piston. How much work is done when the piston moves from the position $L = 1 \text{ m}$ to $L = 1.5 \text{ m}$. Sketch the p - V diagram for this process and show the work done.

Solution: Given: $F = -7000 + 15000 L$

$$\text{We have Work done} = (W_d)_{1-2} = \int p dV$$

$$= \int_1^2 p \cdot A \cdot dL$$

$$= A \int_1^2 p \cdot dL$$

$$\text{But } p = \frac{F}{A} = \frac{-7000 + 15000L}{A}$$

$$\therefore (W_d)_{1-2} = A \int_1^2 \left(\frac{-7000 + 15000L}{A} \right) \cdot dL$$

$$= \int_{L_1}^{L_2} (-7000 + 15000L) \cdot dL$$

$$= -7000 (L_2 - L_1) + 15000/2 (L_2^2 - L_1^2)$$

$$= -7000 (0.5) + 15000/2 (1.25)$$

$$= -3500 + 9375$$

$$= 5875 \text{ J} = 5.875 \text{ kJ}$$

Sketching of p-V diagram:

F	8000	9500	11000	12500	14000	15500
L	1	1.1	1.2	1.3	1.4	1.5

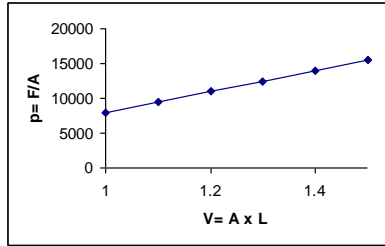

13. An insulated system contains a mixture of ice and water. A paddle wheel is rotated in the system at 100rpm. Torque applied to the shaft is 3 N-m. In order to effect the transformation of 1 kg of ice to liquid water 300 kJ of heat must be transferred to the system. Determine the length of time the paddle wheel must be rotated in order to achieve 2.5 kg reduction in the quantity of ice.

Solution: Given: $T = 3 \text{ N-m}$; $N = 1000 \text{ rpm}$

$$\begin{aligned} \text{Paddle work (done on the system), } W_s &= \frac{2\pi NT}{60} \\ &= \frac{2\pi(1000)3}{60} = 314 \text{ N-m/s} = 314 \text{ J/s} \end{aligned}$$

In order to have a reduction of 2.5 kg of ice into water, the paddle work required is

$$300 (2.5) = 750 \text{ kJ}$$

∴ Length of time for which the paddle wheel should be operated, is

$$\frac{750 \times 10^3}{314} = 2388.5 \text{ sec} \quad \text{i.e., } 39.8 \text{ minutes}$$

14. A system containing 5 kg of a substance is stirred with a torque of 1 N-m at a speed of 500 rpm for 24 hrs. The system mean while expands from 1.5 m^3 to 2.0 m^3 against a constant pressure of 5 bar. Determine the magnitude and direction of net work transfer.

Solution: The system is associated with two interactions with the surroundings i.e., stirring work (surroundings to the system) and displacement work

$$\text{i.e., } W_{1-2} = W_{st(1-2)} + (W_d)_{1-2}$$

Stirring work, $W_{st} = 2\pi NT / 60$

$$= \frac{2\pi(500)1}{60} = 52.359 \text{ n-m/sec}$$

$$\begin{aligned} \therefore W_{st} &= 52.359 \times 24 \times 60 \times 60 \\ &= 4523893 \text{ J} = 4523.893 \text{ kJ} \end{aligned}$$

This is a negative work, as the work is done on the system by the surroundings

$$\begin{aligned} \text{Displacement work, } (W_d)_{1-2} &= \int_1^2 p dV \\ &= p (V_2 - V_1) \\ &= 5 \times 10^5 (2 - 1.5) \end{aligned}$$

$$= 250000 \text{ J} = 250 \text{ kJ}$$

$$\therefore \text{Net work transfer } W_{1-2} = -4523.893 + 250 \\ = -4273.89 \text{ kJ}$$

Negative indicated that net work transfer takes place from the surroundings to the system.

15. A mass of 1.5 kg of a substance is compressed in a quasi-static process from 0.1 MPa to 0.7 MPa. The initial pressure density of the substance is 1.16 kg/m^3 . Determine the magnitude of work done on the substance if i) process is $pV = C$ and $pV^{1.4} = C$

Solution: Given: $m = 1.5 \text{ kg}$ $p_1 = 0.1 \times 10^6 \text{ Pa}$ $p_2 = 0.7 \times 10^6 \text{ MPa}$ $\rho_1 = 1.16 \text{ kg/m}^3$

Since $\rho = 1.16 \text{ kg/m}^3$ and $m = 1.5 \text{ kg}$, volume $V_1 = m/\rho = 1.293 \text{ m}^3$

Case i) $pV = C$

$$\text{i.e., } pV = p_1V_1 = p_2V_2 \quad \text{or } V_2 = \frac{p_1V_1}{p_2} = \frac{0.1}{0.7} \times 1.293 = 0.185 \text{ m}^3$$

We have $(W_d)_{1-2} = \int_1^2 p \cdot dV$

$$= \int_1^2 \frac{p_1V_1}{V} \cdot dV$$

$$\text{i.e., } (W_d)_{1-2} = p_1V_1 \ln \frac{V_2}{V_1} \\ = 0.1 \times 10^6 \times 1.293 \ln \frac{0.185}{1.293} \\ = -251595 \text{ J} = -251.595 \text{ kJ}$$

Negative sign indicates that work is done on the system

Case ii) $pV^{1.4} = C$

$$\text{i.e., } p_1V_1^{1.4} = p_2V_2^{1.4} = \therefore V_2 = \left[\frac{p_1V_1^{1.4}}{p_2} \right]^{1/1.4} = 0.322 \text{ m}^3$$

$$\text{We have, adiabatic process } (W_d)_{1-2} = \frac{p_1V_1 - p_2V_2}{\gamma - 1} \\ = \frac{0.1 \times 10^6 (1.293) - 0.7 \times 10^6 (0.322)}{0.4} \\ = -240381 \text{ J} = -240.381 \text{ kJ}$$

Negative sign indicates that work is done on the system

16. O_2 is compressed in a quasi static process according to the relation $pV^{1.2} = C$. The initial conditions are 98 KPa and 20° C and the final pressure is 1000 KPa. Assuming an ideal gas behaviour, determine the work required to compress 100 kg of O_2 . Compare this work with the work of isothermal compression, i.e., $pV = C$.

Solution: $p_1 = 98 \times 10^3 \text{ Pa}$, $T_1 = 293^\circ \text{ K}$, $p_2 = 1000 \times 10^3 \text{ Pa}$, $m = 100 \text{ kg}$

We have for polytropic process,

$$\begin{aligned} (W_d)_{1-2} &= \frac{p_1 V_1 - p_2 V_2}{n-1} \\ &= \frac{mR(T_1 - T_2)}{n-1} \end{aligned}$$

$$\text{But gas constant, } R = \frac{\bar{R}}{M} = \frac{8.3143}{32} = 0.2598 \text{ kJ}$$

Also for polytropic process we have

$$\frac{T_2}{T_1} = \left(\frac{p_2}{p_1} \right)^{n-1/n} \quad \therefore T_2 = 293 \left(\frac{1000}{98} \right)^{0.2} = 431.52^0 \text{K}$$

$$\begin{aligned} \therefore (W_d)_{1-2} &= \frac{100(0.259)(293 - 431.52)}{0.2} \\ &= -17938.34 \text{ kJ} \end{aligned}$$

Negative sign indicates that work is done on the system

Case ii) for isothermal process, we have

$$(W_d)_{1-2} = p_1 V_1 \ln \frac{V_2}{V_1}$$

Considering oxygen to be a perfect gas, we have $pV = mRT$

$$\begin{aligned} \therefore (W_d)_{1-2} &= mRT_1 \ln \frac{p_1}{p_2} \quad \text{since, } pV = C = p_1 V_1 = p_2 V_2 \text{ i.e., } V_2/V_1 = p_1/p_2 \\ &= -17626.94 \text{ kJ} \end{aligned}$$

Negative sign indicates that work is done on the system

17. The following data refer to a 12 Cylinder, single-acting, two-stroke marine Diesel engine:

Cylinder diameter-0.8m

Stroke of piston-1.2m

Area of indicator diagram- $5.5 \times 10^{-4} \text{ m}^2$

Length of diagram-0.06m

Spring value-147 MPa per m

Find the net rate of work transfer from the gas to the piston in kW.

Solution: Mean effective pressure, P_m , is given by

$$\begin{aligned} P_m &= \frac{a_d}{l_d} * \text{spring constant} \\ &= \frac{5.5 \times 10^{-4} \text{ m}^2}{0.06} \times 147 \frac{\text{MPa}}{\text{m}} \\ &= 1.35 \text{ MPa} \end{aligned}$$

One engine cycle is completed in two strokes of the piston or one revolution of the crank shaft.

\therefore Work done in one minute = $P_m LAN$

$$= 1.35 \times 1.2 \times \frac{\pi}{4} (0.8)^2 \times 150$$

$$= 122 \text{ MJ}$$

Since the engine is single-acting, and it has 12 cylinders, each contributing an equal power, the rate of work transfer from the gas to the piston is given by

$$W = 122 \times 12 \text{ MJ/min}$$

$$= 24.4 \text{ MJ/s}$$

$$= 24.4 \text{ MW} = 24,400 \text{ kW}$$

18. A gas system has mass m , occupies a volume V at a pressure of p and temperature T . These

properties are related by the equation $\left[p + \frac{a}{V^2} \right] [V - b] = mRT$ where a , b and R are constants.

Obtain an expression for the displacement work done by this gas system during a constant temperature process where the gas expands from 1 m^3 to 10 m^3 at a temperature of 293 K .

Assume $a = 15.7 \times 10^4 \text{ Nm}^4$, $b = 1.07 \times 10^{-2}$ and $R = 0.278 \text{ kJ/kg-K}$.

Solution: For a given gas, $\left[p + \frac{a}{V^2} \right] [V - b] = mRT$

Solving for p we get, $p = \left[\frac{mRT}{(V - b)} - \frac{a}{V^2} \right]$

\therefore Displacement work $= (W_d)_{1-2} = \int p dv$

$$= \int_{V_1}^{V_2} \left[\frac{mRT}{(V - b)} - \frac{a}{V^2} \right] dv = mRT \ln \left\{ \frac{(V_2 - b)}{(V_1 - b)} \right\} + a \left(\frac{1}{V_2} - \frac{1}{V_1} \right)$$

On substituting the values we get, $(W_d)_{1-2} = 1744.8 \times 10^3 \text{ J} = 1744.8 \text{ kJ}$

FIRST LAW OF THERMODYNAMICS

First Law of Thermodynamics: Joule's Experiments, Equivalence of heat work. Statement of the 1st law of thermodynamics, extension of the 1st law to non cyclic processes, energy, energy as a property, modes of energy, pure substance; Definition, two property rule, specific heat at constant volume, enthalpy, specific heat at constant pressure. Extension of the 1st law to control volume; Steady state-steady flow energy equation, important applications, analysis of unsteady processes such as filling and evacuation of vessels with and without heat transfer.

The first law of thermodynamics is often called as the law of the conservation of energy, with particular reference to heat energy and mechanical energy i.e., work.

First law of thermodynamics for a closed system undergoing a cyclic process

The transfer of heat and the performance of work may both cause the same effect in a system. Energy which enters a system as heat may leave the system as work, or energy which enters the system as work may leave as heat. Hence, by the law of conservation of energy, the net work done

by the system is equal to the net heat supplied to the system. The first law of thermodynamics can therefore be stated as follows:

“When a system undergoes a thermodynamic cyclic process, then the net heat supplied to the system from the surroundings is equal to the net work done by the system on its surrounding”.

$$\text{i.e., } \oint \delta Q = \oint \delta W \text{ where } \oint \text{ represents the sum for a complete cycle.}$$

The first law of thermodynamics cannot be proved analytically, but experimental evidence has repeatedly confirms its validity and since no phenomenon has been shown to contradict it, therefore the first law is accepted as a ‘law of nature’.

Joule’s Experiment:

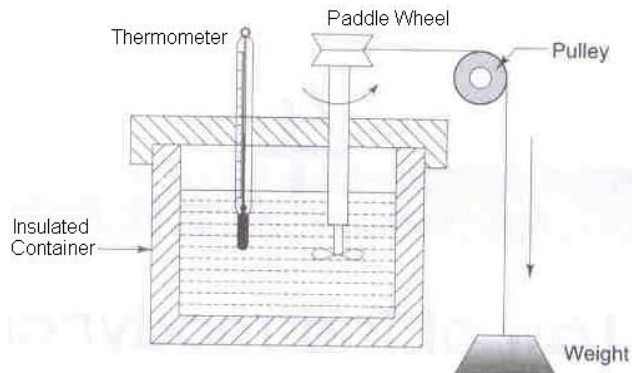

Figure: Joule’s Experiment

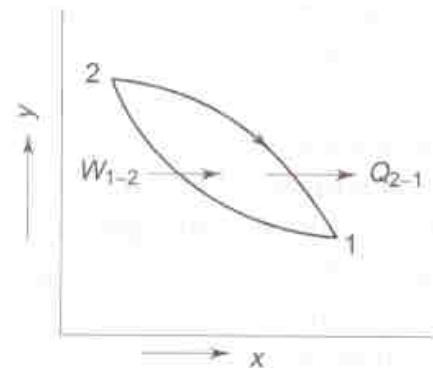

Figure: Cycle completed by a system with two energy interactions i.e., work transfer followed by heat transfer

Figure shows the experiment for checking the first law of thermodynamics. The work input to the paddle wheel is measured by the fall of weight, while the corresponding temperature rise of liquid in the insulated container is measured by the thermometer.

The process 1-2 undergone by the system is shown in figure i.e., W_{1-2} . Let the insulation be removed. The system and the surrounding interact by heat transfer till the system returns to its original temperature, attaining the condition of thermal equilibrium with the atmosphere. The amount of heat transfer Q_{2-1} from the system during this process 2-1 is shown in figure. The system thus executes a cycle, which consists of a definite amount of work input W_{1-2} to the system followed by the transfer of an amount of heat Q_{2-1} from the system.

Joule carried out many such experiments with different type of work interactions in a variety of systems, he found that the net work input the fluid system was always proportional to the net heat transferred from the system regardless of work interaction. Based on this experimental evidence Joule stated that,

“When a system (closed system) is undergoing a cyclic process, the net heat transfer to the system is directly proportional to the net work done by the system”. This statement is referred to as the first law for a closed system undergoing a cyclic process.

$$\text{i.e., } \oint \delta Q \propto \oint \delta W$$

If both heat transfer and work transfer are expressed in same units as in the S.I. units then the constant of proportionality in the above equation will be unity and hence the mathematical form of first law for a system undergoing a cyclic process can be written as

$$\text{i.e., } \oint \delta Q = \oint \delta W$$

If the cycle involves many more heat and work quantities as shown in figure, the same result will be found.

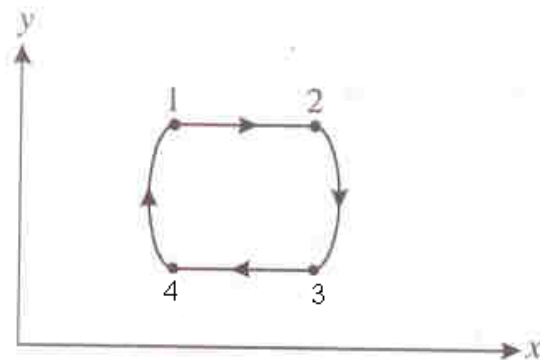

Figure: Cyclic Process on a Property Diagram

For this cyclic process the statement of first law can be written as

$$\oint_{1-2-3-4-1} \delta Q = \oint_{1-2-3-4-1} \delta W$$

The cyclic integral in the above equation can be split into a series of non cyclic integral as

$$\int_1^2 \delta Q + \int_2^3 \delta Q + \int_3^4 \delta Q + \int_4^1 \delta Q = \int_1^2 \delta W + \int_2^3 \delta W + \int_3^4 \delta W + \int_4^1 \delta W$$

$$\text{or } {}_1Q_2 + {}_2Q_3 + {}_3Q_4 + {}_4Q_1 = {}_1W_2 + {}_2W_3 + {}_3W_4 + {}_4W_1$$

$$\text{i.e., } \oint \delta Q = \oint \delta W$$

$$\text{or } (\Sigma Q)_{\text{cycle}} = (\Sigma W)_{\text{cycle}}$$

This is the first law for a closed system undergoing a cyclic process. i.e., it is stated as “When a closed system is undergoing a cyclic process the algebraic sum of heat transfers is equal to the algebraic sum of the work transfers”.

First law for a closed system undergoing a non-cyclic process (i.e., for a change of state):

If a system undergoes a change of state during which both heat transfer and work transfer are involved, the net energy transfer will be stored or accumulated within the system.

If Q is the amount of heat transferred to the system and W is the amount of work transferred from the system during the process as shown in figure,

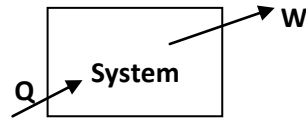

The net energy transfer ($Q-W$) will be stored in the system. Energy in storage is either heat or work and is given the name internal energy or simply, the energy of the system.

$\therefore Q-W = \Delta E$ where ΔE is the increase in the energy of the system

or $Q = \Delta E + W$

If there are more energy transfer quantities involved in the process as shown in figure.

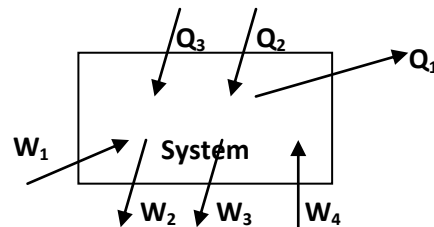

First law gives

$(Q_2 + Q_3 - Q_1) = \Delta E + (W_2 + W_3 - W_1 - W_4)$

i.e., energy is thus conserved in the operation. Therefore the first law is a particular formulation of the principle of the conservation of energy. It can be shown that the energy has a definite value at every state of a system and is therefore, a property of a system.

Energy – A property of the system:

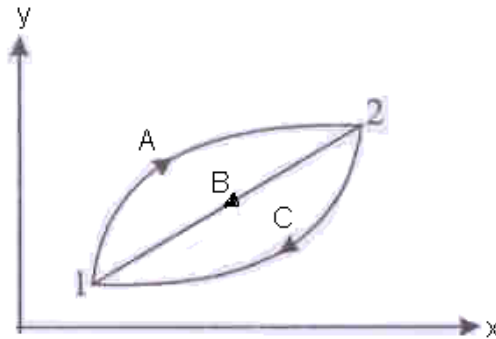

Figure: First law to a non cyclic process

Consider a system that undergoes a cycle, changing from state 1 to state 2 by process A and returning from state 2 to state 1 by process B.

We have from 1st law of thermodynamics, $\oint \delta Q = \oint \delta W$

For the process, 1-A-2-B-1, $\oint_{1-A-2-B-1} \delta Q = \oint_{1-A-2-B-1} \delta W$

Considering the two separate processes, we have

$$\int_A^1 \delta Q + \int_B^2 \delta Q = \int_A^1 \delta W + \int_B^2 \delta W \quad \text{--- (1)}$$

Now consider another cycle, the system changing from state 1 to state 2 by process A, as before and returning to state 1 by process C. For this cycle we can write

$$\int_A^1 \delta Q + \int_C^2 \delta Q = \int_A^1 \delta W + \int_C^2 \delta W \quad \text{--- (2)}$$

Subtracting (2) from (1), we get

$$\int_B^1 \delta Q - \int_C^2 \delta Q = \int_B^1 \delta W + \int_C^2 \delta W$$

Or, by rearranging, $\int_B^1 (\delta Q - \delta W) = \int_C^2 (\delta Q - \delta W)$

Since B and C represent arbitrary processes between state 1 to state 2, we conclude that the quantity $(\delta Q - \delta W)$ is the same for all processes between state 1 and state 2. $\therefore (\delta Q - \delta W)$ depends only on the initial and final states and not on the path followed between the two states. \therefore This is a point function and differential is a property of the system. This property is called the energy of the system, E. Therefore, we can write

$$\delta Q - \delta W = dE$$

$$\text{Or } \delta Q = dE + \delta W$$

If it is integrated between initial and final states, 1 and 2, we get

$$Q_{1-2} = E_2 - E_1 + W_{1-2}$$

$$\text{i.e., } Q_{1-2} - W_{1-2} = E_2 - E_1$$

The above equation is the statement of first law for a closed system undergoing a non cyclic process, where Q_{1-2} represents the net heat transfer between the system and the surroundings during the process, W_{1-2} represents net work transfer between the system and the surroundings during the process and $(E_2 - E_1)$ represents the change in the energy of the system during the process.

Classification of Energy of the System:

The energy E is an extensive property and the specific energy $e = E/m$ (J/kg) is an intensive property. Energy E represents the total energy of the system.

i.e., $E = \text{kinetic energy (KE)} + \text{Potential Energy (PE)} + \text{remaining forms of energy.}$

Since K.E and P.E are macroscopic quantities and can be measured very easily and so they are considered separately in thermodynamics. The remaining energies (associated with the motion and position of the molecules, energy associated with the structure of the atom, chemical energy etc),

which cannot be measured directly and is the summation of all microscopic energies is called internal energy of the system.

Internal energy:

It is the energy associated with internal structure of matter. This energy cannot be determined in its absolute values. But it is possible to determine the change in internal energy of the system undergoing a process by first law of thermodynamics.

$$\therefore \text{Total energy } E = \text{KE} + \text{PE} + \text{IE}$$

Since the terms comprising E are point functions, we can write

$$dE = d(\text{KE}) + d(\text{PE}) + dU$$

The first law of thermodynamics for a change of state of a system may therefore be written as

$$\delta Q = dU + d(\text{KE}) + d(\text{PE}) + \delta W$$

In words this equation states that as a system undergoes a change of state, energy may cross the boundary as either heat or work, and each may be positive or negative. The net change in the energy of the system will be exactly equal to the net energy that crosses the boundary of the system. The energy of the system may change in any of three ways, namely, by a change in IE, KE or P.E

Sub. For KE and PE in the above equation

$$\delta Q = dU + \frac{d(mV^2)}{2} + d(mgZ) + \delta W$$

In the integral form this equation is, assuming 'g' is a constant

$$Q_{1-2} = U_2 - U_1 + \frac{m(V_2^2 - V_1^2)}{2} + mg(Z_2 - Z_1) + W_{1-2}$$

In most of the situations the changes in KE and PE are very small, when compared with the changes in internal energies. Thus KE and PE changes can be neglected.

$$\therefore \delta Q = dU + \delta W$$

$$\text{or } Q_{1-2} = U_2 - U_1 + W_{1-2}$$

Law of conservation of energy (2nd corollary of first law of thermodynamics)

From first law of thermodynamics $Q_{1-2} = E_2 - E_1 + W_{1-2}$

This equation in effect, a statement of the conservation of energy. The net change of the energy of the system is always equal to the net transfer of energy across the system boundary as heat and work.

For an isolated system, $Q = 0$, $W = 0 \therefore E_2 - E_1 = 0$

\therefore For an isolated system, the energy of the system remains constant.

Therefore, the first law of thermodynamics. may also be stated as follows, “Heat and work are mutually convertible but since energy can neither be created nor destroyed, the total energy associated with an energy conversion remains constant”.

Perpetual Machine of first kind (3rd Corollary):

Any system which violates the first law of thermodynamics is called the Perpetual Motion machine of first kind. i.e., “It is impossible to construct a perpetual motion machine of first kind”. A perpetual machine is one which can do continuous work without receiving energy from other systems or surroundings. It will create energy on its own and thus violates first law. But from our experience we also know that it is impossible to construct such a machine, as frictional resistance would not allow it to run for an indefinite period.

The Pure Substance

The system encountered in thermodynamics is often quite less complex and consists of fluids that don not change chemically, or exhibit significant electrical, magnetic or capillary effects. These relatively simple systems are given the generic name the Pure Substance.

Definition

A system is set to be a pure substance if it is (i) homogeneous in chemical composition, (ii) homogeneous in chemical aggregation and (iii) invariable in chemical aggregation.

Homogeneous in chemical composition means that the composition of each part of the system is same as the composition of any other part. Homogeneous in chemical aggregation implies that the chemical elements must be chemically combined in the same way in all parts of the system. Invariable in chemical aggregation means that the chemical aggregation should not vary with respect to time.

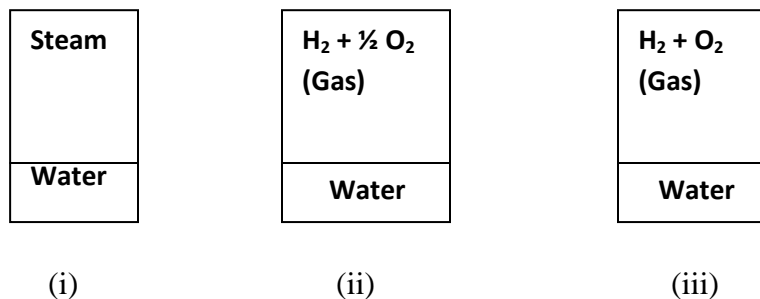

Satisfies condition (i) Satisfies condition (i) Does not satisfies condition (i)
 Satisfies condition (ii) Does not satisfies condition (ii) Satisfies condition (iii)

Figure Illustration of the definition of pure substance

In figure three systems are shown. The system (i) shown in the figure is a mixture of steam and water. It is homogeneous in chemical composition because in every part of the system we have, for

every atom of oxygen we have two atoms of hydrogen, whether the sample is taken from steam or water. The same is through for system (ii) consisting of water and uncombined mixture of hydrogen and oxygen. System (iii) however is not homogeneous in chemical composition because in the upper part of the system hydrogen and oxygen are present in the ratio 1:1 where as in the bottom portion they are present in the ratio 2:1.

System (i) also satisfies condition (ii), because both hydrogen and oxygen have combined chemically in every part of the system. System (ii) on the other hand does not satisfies condition (ii) because the bottom part of the system has two elements namely hydrogen and oxygen have chemically combined where as in the upper part of the system the (ii) elements appear as a mixture of two individual gases.

Invariable in chemical aggregation means that the state of chemical combination of the system should not change with time. Thus the mixture of hydrogen and oxygen, if it is changing into steam during the time the system was under consideration, then the systems chemical aggregation is varying with time and hence this system is not a pure substance. Thus the system (i) is a pure substance where as the systems (ii) and (iii) are not pure substances.

The Two Property Rule for a Pure Substance

The thermodynamics state of a pure substance of a given mass can be fixed by specifying two independent properties provided (i) the substance is in equilibrium and (ii) the effects of gravity, motion, capillarity, electricity and magnetism are negligible.

The above rule indicates that if the values of two properties of a pure substance are fixed then the values for all other properties are fixed. This means that there is a definite relation between the two independent properties and each of the other properties. Each of these relations is called “Equation of state” for a pure substance. The equation of state for a pure substance can be in any one of the following forms: (i) Algebraic equation (example: perfect gas equation), (ii) Tables (example: steam tables) and (iii) Charts (example: Mollier chart for steam).

Specific heat, C

When interaction of heat takes place between a closed system and its surroundings, the internal energy of the system changes. If δQ is the amount of heat transferred to raise the temperature of 1 kg of substance by dT , then, specific heat $C = \delta Q/dT$

As we know, the specific heat of gas depends not only on the temperature but also upon the type of the heating process. i.e., specific heat of a gas depends on whether the gas is heated under constant volume or under constant pressure process.

\therefore We have $dQ = m C_v \cdot dT$ for a rev. non-flow process at constant volume
and $dQ = m C_p \cdot dT$ for a rev. non-flow process at constant pressure

For a perfect gas, C_p & C_v are constant for any one gas at all pressure and temperatures. Hence, integrating above equations.

Flow of heat in a rev. constant pressure process = $m C_p (T_2 - T_1)$

Flow of heat in a rev. constant volume process = $m C_V (T_2 - T_1)$

The internal energy of a perfect gas is a function of temperature only. i.e, $u = f(T)$, to evaluate this function, let 1 kg of gas be heated at constant volume

From non-flow energy equation, $\delta Q = dU + \delta W$

$$\delta W = 0 \quad \text{since volume remains constant}$$

$$\therefore \delta Q = dU = C_V \cdot dT$$

Int. $U = C_V T + k$ where k is a constant

For mass m , Int. energy = $m C_V T$

Any process between state 1 to state 2,

Change in int. energy = $m C_V (T_2 - T_1)$

$$(U_2 - U_1) = m C_V (T_2 - T_1)$$

We can also find the relationship between C_p & C_V & shown that

$$C_p - C_V = R; \quad \frac{C_p}{C_V} = \gamma; \quad C_V = \frac{R}{r-1} \quad \& \quad C_p = \frac{rR}{(r-1)}$$

Enthalpy: Consider a system undergoing a quasi equilibrium constant pressure process. We have from 1st law of thermodynamics for a non-flow process,

$$Q_{1-2} = U_2 - U_1 + W_{1-2}$$

$$W_{1-2} = \int_1^2 p \, dv$$

Since pressure is constant $W_{1-2} = p (V_2 - V_1)$

$$\begin{aligned} \therefore Q_{1-2} &= U_2 - U_1 + p (V_2 - V_1) \\ &= (U_2 + p_2 V_2) - (U_1 + p_1 V_1) \end{aligned}$$

i.e., heat transfer during the process is given in terms of the change in the quantity $(U + pV)$ between initial and final states. Therefore, it find more convenient in thermodynamics to define this sum as a property called Enthalpy (H)

$$\text{i.e., } H = U + pV$$

\therefore In a constant pressure quasi equilibrium process, the heat transfer is equal to the change in enthalpy which includes both the change in internal energy and the work for this particular process.

The enthalpy of a fluid is the property of the fluid, since it consists of the sum of a property and the product of the two properties. Since enthalpy is a property, like internal energy, pressure, specific volume and temperature, it can be introduced into any problem whether the process is a flow or a non-flow process.

$$\begin{aligned} \text{For a perfect gas, we have } h &= u + pV \\ &= C_V T + RT = (C_V + R) T = C_p T \\ \text{i.e., } h &= C_p T \quad \& \quad H = m C_p T \end{aligned}$$

For any process, $\delta Q = dH = m C_p dT$

\therefore For a process between states 1 & 2

$$\text{Change in enthalpy} = (H_2 - H_1) = m C_p (T_2 - T_1)$$

Specific heat at Constant Volume:

When heat interaction takes place at constant volume, $\delta W = 0$ and from 1st law of thermodynamics, for unit mass, $(\delta q)_v = dU$

The amount of heat supplied or removed per degree change in temperature, when the system is kept under constant volume, is called as the specific heat at constant volume,

$$\text{Or } C_v = \left[\frac{\delta Q}{dT} \right]_v \cong \left[\frac{dU}{dT} \right]_v$$

$$\text{Or } dU = C_v dT$$

Specific heat at Constant pressure:

When heat interaction is at constant pressure, $(\delta q)_p = dh$

The amount of heat added or removed per degree change in temperature, when the system is kept under constant pressure, is called as the specific heat at constant pressure.

$$\text{Or } C_p = \left[\frac{\delta Q}{dT} \right]_p \cong \left[\frac{dh}{dT} \right]_p$$

$$\text{Or } dh = C_p dT$$

Application of 1st law of thermodynamics to non-flow or closed system:**a) Constant volume process (V = constant)**

Applying 1st law of thermodynamics to the process,

$$\begin{aligned} Q_{1-2} &= U_2 - U_1 + W_{1-2} \\ &= U_2 - U_1 + 0 \end{aligned}$$

$$\text{i.e., } Q_{1-2} = C_v (T_2 - T_1)$$

For mass 'm' of a substance, $Q = mC_v (T_2 - T_1)$

b) Constant pressure (p = Constant)

Applying 1st law of thermodynamics to the process,

$$Q_{1-2} = u_2 - u_1 + W_{1-2}$$

$$\text{The work done, } W_{1-2} = \int_1^2 p dV = p (V_2 - V_1)$$

$$\begin{aligned} \text{i.e., } Q_{1-2} &= u_2 - u_1 + p (V_2 - V_1) = (u_2 + pV_2) - (u_1 + pV_1) \\ &= h_2 - h_1 \end{aligned}$$

$$\text{i.e., } Q = C_p (T_2 - T_1)$$

For mass 'm' of a substance, $Q = mC_p (T_2 - T_1)$

c) Constant temperature process (Isothermal process, T = constant)

Applying 1st law of thermodynamics to the process,

$$Q_{1-2} = U_2 - U_1 + W_{1-2}$$

$$= C_V (T_2 - T_1) + W_{1-2}$$

$$\text{i.e., } Q_{1-2} = W_{1-2} \quad \because T_1 = T_2$$

$$Q_{1-2} = p_1 V_1 \ln V_2/V_1$$

$$= p_1 V_1 \ln p_1/p_2$$

d) Reversible adiabatic process ($pV^\gamma = \text{constant}$)

Applying 1st law of thermodynamics to the process,

$$Q_{1-2} = U_2 - U_1 + W_{1-2}$$

$$0 = u_2 - U_1 + W_{1-2} \quad \text{--- (1)}$$

$$\text{Or } (U_1 - U_2) = \frac{p_1 V_1 - p_2 V_2}{\gamma - 1}$$

$$(U_1 - U_2) = \frac{R(T_1 - T_2)}{\gamma - 1}$$

The above equation is true for an adiabatic process whether the process is reversible or not. In an adiabatic experiment, the work done W_{1-2} by the fluid is at the expense of a reduction in the internal energy of the fluid. Similarly in an adiabatic compression process, all the work done on the fluid goes to increase the internal energy of the fluid.

To derive $pV^\gamma = C$: For a reversible adiabatic process

We have $\delta q = du + \delta w$

For a reversible process, $\delta w = p dV$

$$\therefore \delta q = du + p dV$$

$$= 0 \quad \because \text{For an adiabatic process } \delta q = 0$$

Also for a perfect gas, $pV = RT$ or $p = \frac{RT}{V}$

$$\therefore dU + RT \frac{dV}{V}$$

Also, $u = C_V T$ or $du = C_V dT$

$$\therefore C_V dT + RT \frac{dV}{V}$$

$$\text{or } C_V \frac{dT}{T} + R \frac{dV}{V} = 0$$

Int., $C_V \ln T + R \ln V = \text{constant}$

Sub. $T = pV/R$

$$C_V \ln \frac{pV}{R} + R \ln V = \text{constant}$$

$$\text{Or } \ln \frac{pV}{R} + \frac{R}{C_V} \ln V = \text{constant}$$

$$\text{Also, } C_v = \frac{R}{\gamma - 1} \text{ or } \frac{R}{C_v} = \gamma - 1$$

$$\therefore \ln \frac{pV}{R} + (\gamma - 1) \ln V = \text{constant}$$

$$\therefore \ln \frac{pV}{R} + \ln V^{\gamma-1} = \text{constant}$$

$$\text{or } \ln \frac{pVxV^{\gamma-1}}{R} = \text{constant}$$

$$\text{i.e., } \ln \frac{pV^\gamma}{R} = \text{constant}$$

$$\text{or } \frac{pV^\gamma}{R} = e^{\text{constant}} = \text{constant}$$

$$\text{i.e., } pV^\gamma = \text{constant}$$

we have $pV = RT$

$$\text{or } p = \frac{RT}{V}$$

sub. This value of p in $pV^\gamma = C$

$$\frac{RT}{V} V^\gamma = C \quad \text{or } TV^{\gamma-1} = \text{constant} \quad \text{--- (a)}$$

Also, $V = \frac{RT}{P}$ sub. This in equation pressure $^\gamma = C$

$$p \left(\frac{RT}{p} \right)^\gamma = \text{constant}$$

$$\therefore \frac{T^2}{p^{\gamma-1}} = \text{constant} \quad \text{or } \frac{T}{p^{\left(\frac{\gamma-1}{\gamma}\right)}} = \text{constant} \quad \text{--- (b)}$$

\therefore For a reversible adiabatic process for a perfect gas between states 1 & 2, we can write

$$p_1 V_1^\gamma = p_2 V_2^\gamma \quad \text{or } \frac{p_2}{p_1} = \left(\frac{V_1}{V_2} \right)^\gamma \quad \text{--- (c)}$$

$$T_1 V_1^{\gamma-1} = T_2 V_2^{\gamma-1} \quad \text{or } \frac{T_2}{T_1} = \left(\frac{V_1}{V_2} \right)^{\gamma-1} \quad \text{--- (d)}$$

$$\frac{T_1}{p_1^{\frac{\gamma-1}{\gamma}}} = \frac{T_2}{p_2^{\frac{\gamma-1}{\gamma}}} \quad \text{or } \frac{T_2}{T_1} = \left(\frac{p_2}{p_1} \right)^{\frac{\gamma-1}{\gamma}} \quad \text{--- (e)}$$

The work done in an adiabatic process is $W = u_1 - u_2$

The gain in I.E. of a perfect gas, is $u_2 - u_1 = C_V (T_2 - T_1)$

$$W = C_V (T_1 - T_2)$$

$$\text{But } C_V = \frac{R}{\gamma - 1}$$

$$\therefore W = \frac{R(T_1 - T_2)}{\gamma - 1}$$

$$\text{Using } pV = RT, \quad W = \frac{p_1 V_1 - p_2 V_2}{\gamma - 1}$$

e) Poly tropic process ($PV^n = \text{constant}$)

Applying 1st law of thermodynamics, $Q_{1-2} = u_2 - u_1 + W_{1-2}$

$$= (u_2 - u_1) + \frac{R(T_1 - T_2)}{n - 1}$$

$$\text{i.e., } Q = \frac{R(T_1 - T_2)}{n - 1} - C_V (T_1 - T_2)$$

$$\text{Also } C_V = \frac{R}{\gamma - 1} \text{ sub. \& simplifying } Q = \left(\frac{\gamma - n}{n - 1} \right) W$$

In a poly tropic process, the index n depends on the heat and work quantities during the process.

Problems:

1. In a cyclic process, heat temperature are + 14.7 kJ, -25.2 kJ, -3.56 kJ and +31.5 kJ. What is the net work for this cyclic process.

Solution: 1st law of thermodynamics for a cyclic process is $\oint \delta Q = \oint \delta W$

i.e., Net work = 14.7 – 25.2 -3.56 + 31.5
= 17.44 kJ

2. Consider a cyclic process in a closed system which includes three heat interactions, namely $Q_1 = 20$ kJ, $Q_2 = -6$ kJ, and $Q_3 = -4$ kJ and two work interactions for which $W_1 = 4500$ N-m. Compute the magnitude of the second work interaction W_2 in Nm.

Solution: We have for a closed system undergoing cyclic process,

$$\oint \delta Q = \oint \delta W$$

$$20000 - 6000 - 4000 = 4500 + W_2$$

$$\therefore W_2 = 5500 \text{ Nm}$$

3. When the state of a system changes from state 1 to state 3 along the path 1-2-3 as shown in figure, 80 kJ of heat flows into the system and the system does 30 kJ of work. (a) How much heat flows into the system along the path 1-4-3 if work done by the system is 10 kJ (b) when the state of the system is returned from state 3 to state 1 along the curved path, the work done on the system is 20 kJ. Does the system absorb or liberate heat? Find its magnitude. (c) If $U_1 = 0$ and $U_4 = 40$ kJ, find the heat absorbed in the process 1-4 and 4-3 respectively.

Solution:

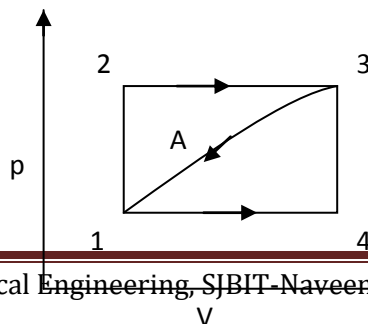

a) Along the path 1-2-3,

From 1st law of thermodynamics, $Q_{1-3} = U_3 - U_1 + W_{1-3}$

From the data given, $80 = (U_3 - U_1) + 30$

$$\therefore (U_3 - U_1) = 50 \text{ kJ}$$

Along the path 1-4-3, we have

$$Q_{1-3} = U_3 - U_1 + W_{1-3}$$

From the data given, $Q_{1-3} = 50 + 10$

$$= 60 \text{ kJ} \quad \therefore U \text{ is property of a system}$$

i.e., Work is done by the system

b) Along the path 3-A-1,

$$(U_1 - U_3) = Q_{3-1} - W_{3-1}$$

Or $Q_{3-1} = (U_1 - U_3) + W_{3-1}$

$$= -50 - 20 = -70 \text{ kJ}$$

Negative sign indicates that heat is liberated from the system.

c) Along the path 1-4

$$Q_{1-4} = U_4 - U_1 + W_{1-4}$$

$$= 40 - 0 + 10 \quad (\text{since } W_{1-4-3} = W_{1-4} + W_{4-3} = 10 + 0 = 10)$$

$$= 50 \text{ kJ}$$

Positive sign indicates heat is absorbed by the system

Along the path 4-3

$$Q_{4-3} = U_3 - U_4 + W_{4-3}$$

$$= 50 - 40 + 0 = 10 \text{ kJ}$$

4. A domestic refrigerator is loaded with food and the door closed. During a certain period the machine consumes 1 kWh of energy and the internal energy of the system drops by 5000 kJ.

Find the net heat transfer for the system.

Solution: $W_{1-2} = 1 \text{ kWh} = -1 \times 3600 \text{ kJ}$ $U_2 - U_1 = -5000 \text{ kJ}$

From 1st law, $Q_{1-2} = (U_2 - U_1) + W_{1-2}$

$$= -5000 - 3600 = -8600 \text{ kJ} = -8.6 \text{ MJ}$$

5. For the following process in a closed system find the missing data (all in kJ)

Process	Q	W	U ₁	U ₂	ΔU
---------	---	---	----------------	----------------	----

a)	<u>35</u>	20	-10	<u>5</u>	15
b)	15	-6	<u>-27</u>	-6	<u>21</u>
c)	-7	10	20	<u>3</u>	<u>-17</u>
d)	<u>-27</u>	-7	<u>28</u>	8	-20

Solution: Process (a): $Q = \Delta U + W$
 $= U_2 - U_1 + W_{1-2}$ but $U_2 - U_1 = 15 \therefore U_2 = 5$
 $= 15 + 20 = 35 \text{ kJ}$

Process (b): $Q = U_2 - U_1 + W$
 $15 = -6 - U_1 - 6$
 $27 = -U_1 \therefore U_1 = -27 \text{ kJ}$
 $\therefore \Delta U = U_2 - U_1 = -6 + 27 = 21 \text{ kJ}$

Process (c) $-7 = U_2 - 20 + 10$
 $\therefore U_2 = 3 \text{ kJ} \therefore \Delta U = 3 - 20 = -17 \text{ kJ}$

Process (d) $\Delta U = U_2 - U_1 = -20$
 $= 8 - U_1 = -20 \therefore U_1 = 28 \text{ kJ}$
 $A = 8 - 28 - 7 = -27 \text{ kJ}$

6. A fluid system, contained in a piston and cylinder machine, passes through a complete cycle of four processes. The sum of all heat transferred during a cycle is -340 kJ. The system completes 200 cycles minutes. Complete the following table showing the method for each item, and compute the net rate of work output in kW.

Process	Q (kJ/min)	W (kJ/min)	ΔE (kJ/min)
1-2	0	4340	<u>-4340</u>
2-3	42000	0	<u>42000</u>
3-4	-4200	<u>69000</u>	-73200
4-1	<u>-105800</u>	<u>-141340</u>	<u>35540</u>

Solution: Given $\sum_{cycle} Q = -340 \text{ kJ}$, No. of cycle = 200 cycles / min

Process 1-2: $Q_{1-2} = (E_2 - E_1) + W_{1-2}$
 $0 = \Delta E + W_{1-2}$
 $\therefore \Delta E = -4340 \text{ kJ/min}$

Process 2-3: $42000 = \Delta E + 0$
 $\therefore Q_{1-2} = 42000 \text{ kJ/min}$

Process 3-4: $-4200 = -73200 + W_{3-4}$
 $\therefore W_{3-4} = 69000 \text{ kJ/min}$

Process 4-1: $\sum_{cycle} Q = -340 \text{ kJ}$

The system completes 200 cycle/min
 $\therefore \sum_{cycle} Q = -340 \times 200 = -68000 \text{ kJ / min}$

$$\text{But, } Q_{1-2} + Q_{2-3} + Q_{3-4} + Q_{4-1} = -68000$$

$$\begin{aligned}\therefore Q_{4-1} &= -68000 - 0 - 42000 + 4200 \\ &= -105800 \text{ kJ/min}\end{aligned}$$

Also, $\int dE = 0$, since cyclic integral of any property is zero

$$\therefore (\Delta E)_{1-2} + (\Delta E)_{2-3} + (\Delta E)_{3-4} + (\Delta E)_{4-1} = 0$$

$$-4340 + 42000 - 73200 + (\Delta E)_{4-1} = 0$$

$$\therefore (\Delta E)_{4-1} = 35540 \text{ kJ/min}$$

$$\text{Therefore } Q_{4-1} = (\Delta E)_{4-1} + W_{4-1}$$

$$-105800 = 35540 + W_{4-1}$$

$$\therefore W_{4-1} = -141340 \text{ kJ/min}$$

$$\text{Since } \sum_{\text{cycle}} Q = \sum_{\text{cycle}} W$$

$$= -68000 \text{ kJ/min}$$

$$\therefore \text{Rate of work output} = \frac{-68000}{60} = 1133.33 \text{ kW}$$

First Law of Thermodynamics to open system:

In the case of closed system there is only energy transfer across the system boundary. But in many engineering applications we come across open systems where in both mass and energy transfer takes place. The energies that cross the system boundary are as follows.

- 1) **Internal energy:** Each kg of matter has the internal energy 'u' and as the matter crosses the system boundary the energy of the system changes by 'u' for every kg mass of the matter that crosses the system boundary.
- 2) **Kinetic energy:** Since the matter that crosses the system boundary will have some velocity say \bar{V} each kg of matter carries a K.E. ($\bar{V}^2 / 2$) thus causing the energy of the system to change by this amount for every kg of matter entering the system boundary.
- 3) **Potential energy:** P.E. is measured with reference to some base. Thus 'Z' is the elevation of the matter that is crossing the system boundary, then each kg of matter will possess a P.E. of gZ.
- 4) **Flow energy or Flow work:** This energy is not directly associated with the matter crossing the system boundary. But it is associated with the fact that there must be some pumping process which is responsible for the movement of the matter across the system boundary. Thus external to the system there must be some force which forces the matter across the system boundary and the energy associated with this is called flow energy.

Flow Work: Consider a flow process in which a fluid of mass dm_1 is pushed into the system at section 1 and a mass dm_2 is forced out of the system at section 2 as shown in fig.

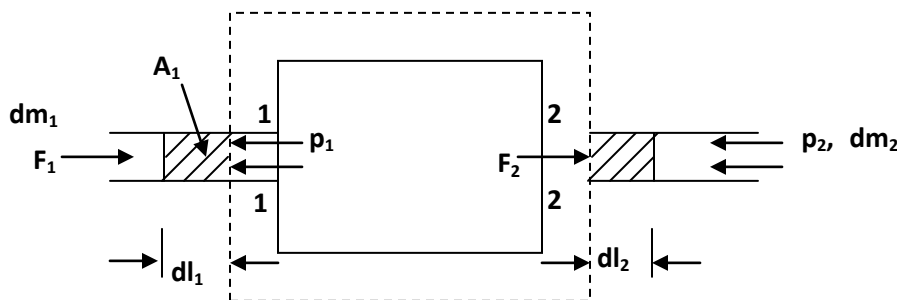

In order to force the fluid to flow across the boundary of the system against a pressure p_1 , work is done on the boundary of the system. The amount of work done is $\delta W = - F_1 \cdot dl_1$,

Where F_1 is the force and dl_1 is the infinitesimal displacement, but $F_1 = p_1 A_1$

$$\therefore \delta W = - p_1 A_1 dl_1 = - p_1 dv_1$$

i.e., the flow work at section 1 = $- p_1 v_1$

Similarly, the work done by the system to force the fluid out of the system at section 2 = $+ p_2 v_2$

Hence net flow work = $p_2 V_2 - p_1 V_1$

For unit mass, the flow work is $(p_2 V_2 - p_1 V_1)$. Flow work is expressed entirely in terms properties of the system. The net flow work depends out on the end state of the fluid and it is a thermodynamics property. Also the fluid contains energies like internal energy, potential energy and due to the motion of the fluid, kinetic energy, in addition to the flow work. When a fluid enters an open system, these properties will be carried into the system. Similarly when the fluid leaves the system, it carries these energies out of the system. Thus in an open system, there is a change in energy of the system.

5. Control Volume: The first and most important step in the analysis of an open system is to imagine a certain region enclosing the system. This region having imaginary boundary is called control volume, which can be defined as follows.

A C.V. is any volume of fixed shape, and of fixed position and orientation relative to the observer. Across the boundaries of the C.V. apart from mass flow, energy transfer in the form of heat and work can take place just as similar to the energy transfer across the boundaries of a system.

Thus the difference between C.V. and system are

- i) The system boundary may and usually does change shape, position, orientation relative to the observer. The C.V. does not by definition.
- ii) Matter may and usually does flow across the system boundary of the C.V. No such flow takes place across the system boundary by definition.

First law of thermodynamics for an open system (Flow process):

We have 1st law of thermodynamics to a closed system as,

$$\begin{aligned} \delta Q - \delta W &= dU + d(KE) + d(PE) \\ &= d[E]_0 \end{aligned}$$

The subscript O refers to the states of the system within the boundary. In the case of open system, energy is transferred into & out of the system not only by heat and work but also by the fluid that enters into and leaves the boundary of the system in the form of internal energy, gravitational potential energy, kinetic energy in addition to the energy in the flow work. Thus, when the first law is applied to an open system, the energy entering into the system must be equal to the energy leaving the system in addition to any accumulation of energy within the system.

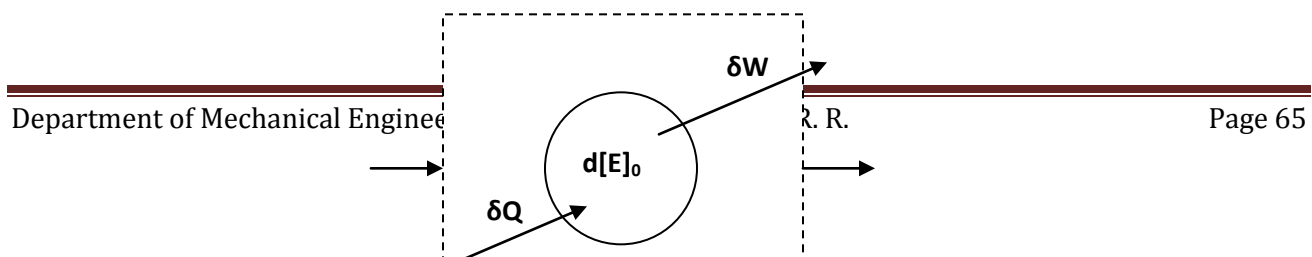

$$dm_1 \left[p_1 v_1 + u_1 + \frac{V_1^2}{2} + gZ_1 \right]$$

$$dm_2 \left[p_2 v_2 + u_2 + \frac{V_2^2}{2} + gZ_2 \right]$$

The flow process is shown in fig. This analysis can be expressed mathematically as,

$$\begin{aligned} \delta Q - \delta W + dm_1 \left[p_1 v_1 + u_1 + \frac{V_1^2}{2} + gZ_1 \right] \\ = dm_2 \left[p_2 v_2 + u_2 + \frac{V_2^2}{2} + gZ_2 \right] + d[E]_0 \quad \text{--- (1)} \end{aligned}$$

Where state (1) is the entering condition and state (2) is the leaving condition of the fluid. This is a general equation of the first law of thermodynamics applied to open system.

Note: The equation is valid to both open and closed system. For closed system, $dm_1=0$ & $dm_2=0$

Energy Equation for open system: The general form of first law of thermodynamics applied to an open system is called steady-flow energy equation (SFEE) i.e., the rate at which the fluid flows through the C.V. is constant or steady flow. SFEE is developed on the basis of the following assumptions.

- i) The mass flow rate through the C.V. is constant, i.e., mass entering the C.V. / unit time = mass leaving the C.V. /unit time. This implies that mass within the C.V. does not change.
- ii) The state and energy of a fluid at the entrance and exit do not vary with time, i.e., there is no change in energy within the C.V.
- iii) The rates of heat and work transfer into or out of the C.V. do not vary with time.

For a steady flow process, $\dot{m} = \dot{m}_1 = \dot{m}_2$ & $d(E)_0 = 0$ as $Q \neq f(T)$ & $W \neq f(T)$

SFEE on the basis unit mass:

Energy entering to the system = energy leaving the system

$$\text{i.e., } \left[u_1 + p_1 v_1 + \frac{V_1^2}{2} + gZ_1 \right] + Q = W + \left[u_2 + p_2 v_2 + \frac{V_2^2}{2} + gZ_2 \right]$$

$$\text{or } \left[h_1 + \frac{V_1^2}{2} + gZ_1 \right] + Q = W + \left[h_2 + \frac{V_2^2}{2} + gZ_2 \right]$$

$$\text{or } (Q - W) = \Delta \left[h + \frac{V^2}{2} + gZ_2 \right]$$

Where Q = heat transfer across the C.V, W = shaft work across the C.V, h = Enthalpy,
 V = velocity, Z = elevation and g = gravitational acceleration

SFEE on the basis of unit time:

$$\dot{Q} - \dot{W} = \dot{m} \Delta \left[h + \frac{V^2}{2} + gZ \right]$$

Where \dot{Q} = heat transfer/unit time; \dot{W} = shaft work / unit time, \dot{m} = mass flow rate / unit time
Hence it can be written as,

$$\dot{Q} + \dot{m} \left(u_1 + p_1 v_1 + \frac{V_1^2}{2} + gZ_1 \right) = \dot{W}_s + \dot{m} \left(u_2 + p_1 v_2 + \frac{V_2^2}{2} + gZ_2 \right)$$

Where $\dot{m}_1 = \rho_1 A_1 V_1$ and $\dot{m}_2 = \rho_2 A_2 V_2$ Where ρ = density A = cross sectional area

But $\dot{m}_1 = \dot{m}_2 = \dot{m}$

$$\therefore \dot{Q} + \dot{m} \left[(h_1 - h_2) + \frac{(V_1^2 - V_2^2)}{2} + g(Z_1 - Z_2) \right] = \dot{W}_s$$

This is the Steady Flow Energy Equation

Displacement work for a flow process (open system):

From SFEE, when changes in kinetic & potential energies are neglected, $\delta q - \delta W = dh$

$$\text{Or } \delta W = \delta q - dh \quad \text{--- (1)}$$

From the 1st law of thermodynamics, we have $\delta q - \delta W = du$

For a rev. process, $\delta W = Pdv$

$$\therefore \delta q = du + Pdv$$

Also, from the definition of enthalpy, $h = u + pv$

$$\text{Or } dh = du + d(pv)$$

Sub δq & dh in equation (i)

$$\begin{aligned} \delta W &= [du + p.dv] - [du + d(pv)] \\ &= p.dv - p.dv - v.dp \quad \therefore W = - \int v dp \end{aligned}$$

Note: With negligible PE & KE, for a non-flow rev. process, the work interaction is equal to $\int_1^2 p.dv$
where as for a steady-flow rev. process, it is equal to $-\int_1^2 v dp$

Application of SFEE:

- i) **Nozzle and Diffuser:** Nozzle is a duct of varying c/s area in which the velocity increases with a corresponding drop in pressure. Since the flow through the nozzle occurs at a very high speed, there is hardly any time for a fluid to gain or lose heat and hence flow of the fluid is assumed to be adiabatic. And also there is no work interaction during the process, i.e., $W_s = 0, Q = 0, Z_1 = Z_2$

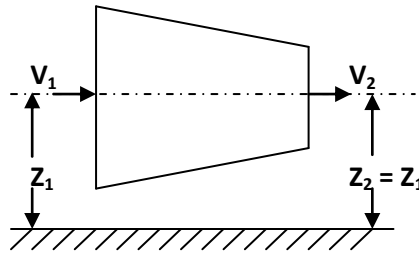

We have from SFEE, $Q - W = \Delta h + \Delta PE + \Delta KE$

$$0 = h_2 - h_1 + \frac{V_2^2 - V_1^2}{2}$$

$$\therefore h_1 - h_2 = \frac{1}{2}(V_2^2 - V_1^2)$$

i.e., the gain in KE during the process is equal to the decrease in enthalpy of the fluid. Diffuser is a device to increase the pressure of a fluid during flow with a corresponding decrease in KE. Thus its function is reverse to that of a nozzle. As final velocity V_2 in a diffuser is very small, it is very often negligible.

- ii) **Turbine and Compressor (rotary):** Turbine is a device which produces work by expanding a high pressure fluid to a low pressure. The fluid is first accelerated in a set of nozzle and then directed through curved moving blades which are fixed on the rotor shaft. The direction of the fluid changes which it flows through the moving blades, due to which there is a change in momentum and a force exerted on the blades producing torque on the rotor shaft. Since the velocity of flow of the fluid through the turbine is very high, the flow process is generally assumed to be adiabatic, hence heat transfer $q = 0$. The change in PE is neglected as it is negligible.

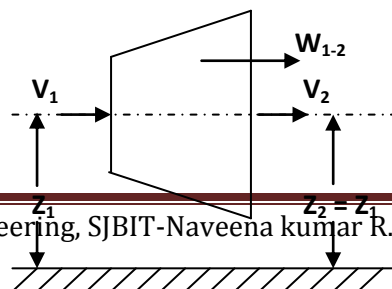

∴ SFEE is $W_{1-2} = (h_1 - h_2) - \frac{1}{2} (V_2^2 - V_1^2)$

If mass flow rate is \dot{m} , then,

$$\dot{W}_{1-2} = \dot{m}(h_1 - h_2) - \frac{1}{2} \dot{m}(V_2^2 - V_1^2) \text{ Watts}$$

i.e., power developed by the turbine

Compressor is a device in which work is done on the fluid to raise its pressure. A rotary compressor can be regarded as a reversed turbine. Since work is done on the system, the rate of work in the above equation is negative and the enthalpy after compression h_2 will be greater than the enthalpy before compression h_1 .

iii) **Throttling Process:** When a fluid steadily through restricted passages like a partially closed valve, orifice, porous plug etc., the pressure of the fluid drops substantially and the process is called throttling. In a throttling process, expansion of the fluid takes place so rapidly that no heat transfer is possible between the system and the surroundings. Hence the process is assumed to occur adiabatically. The work transfer in this process is zero.

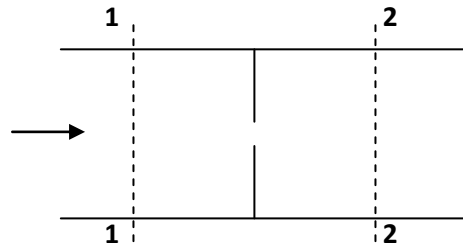

SFEE is $Q_{1-2} - W_{1-2} = \Delta h + \Delta KE + \Delta PE$

We have, $Q = 0$; $W = 0$; $Z_1 = Z_2$, $V_1 \cong V_2$

∴ $0 - 0 = h_2 - h_1 + 0 + 0$ i.e., $h_1 = h_2$

∴ In a throttling process, the enthalpy remains constant. The throttling process is irreversible because when a fluid is throttled, it passes through a series of non-equilibrium states.

iv) **Heat Exchanger:** A heat exchanger is a device in which heat is transferred from one fluid to another. It is used to add or reduced heat energy of the fluid flowing through the device. Radiator in an automobile, condenser in a steam power and refrigeration plants, evaporator in a refrigerator are examples of heat exchangers. There will be no work interaction during the flow of the fluid through any heat exchanger.

Eg: i) Steam condenser: Used to condense the steam. It a device in which steam loses heat as it passes over the tubes through which water is flowing.

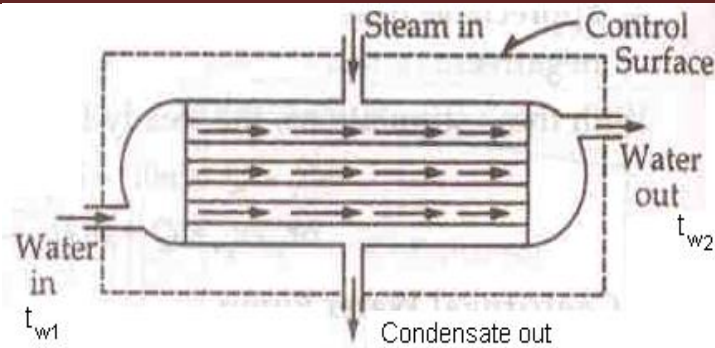

Figure: Heat Exchanger

We have $\Delta KE = 0$, $\Delta PE = 0$ (as their values are very small compared to enthalpies)

$W = 0$ (since neither any work is developed nor absorbed)

\therefore SFEE is $Q = h_2 - h_1$

i.e., $h_1 - Q = h_2$ --- (1)

Where Q = heat lost by 1 kg of steam passing through the condenser.

Assuming there are no other heat interactions except the heat transfer between steam and water, then Q = heat gained by water passing through the condenser.

$$= \dot{m}_w (h_{w_2} - h_{w_1}) = \dot{m}_w C_w (T_{w_2} - T_{w_1})$$

Substituting Q in the above equation (1),

$$h_2 - h_1 = \dot{m}_w C_w (T_{w_2} - T_{w_1})$$

Where \dot{m}_w = mass of cooling water passing through the condenser

C_w = specific heat of water

In a condenser there are 2 steady flow streams namely (i) Vapour that losses heat (ii) The coolant (water) that receives heat.

Let \dot{m}_w = mass flow rate of coolant

\dot{m}_s = mass flow rate of steam

h_{1w} = Enthalpy-coolant entry

h_{1s} = Enthalpy-steam entry

h_{2w}, h_{2s} = Enthalpy of coolant, steam at exit

$$\dot{m}_w h_{1w} + \dot{m}_s h_{1s} = \dot{m}_w h_{2w} + \dot{m}_s h_{2s}$$

$$\text{or } \frac{\dot{m}_w}{\dot{m}_s} = \frac{(h_{2s} - h_{1s})}{(h_{1w} - h_{2w})}$$

ii) Evaporator: An evaporator is a component of a refrigeration system and is used to extract heat from the chamber which is to be kept at low temperature. The refrigerating liquid enters the

evaporator, absorbs latent heat from the chamber at constant pressure and comes out as a vapour. SFEE is

$$\dot{m} h_1 + \dot{Q} = \dot{m} h_2 \quad \text{Since } \dot{W} = 0, \Delta KE = \Delta PE = 0$$

$$\therefore \dot{Q} = \dot{m} (h_2 - h_1)$$

\dot{Q} is taken as positive because heat flows from the chamber to the evaporator coil.

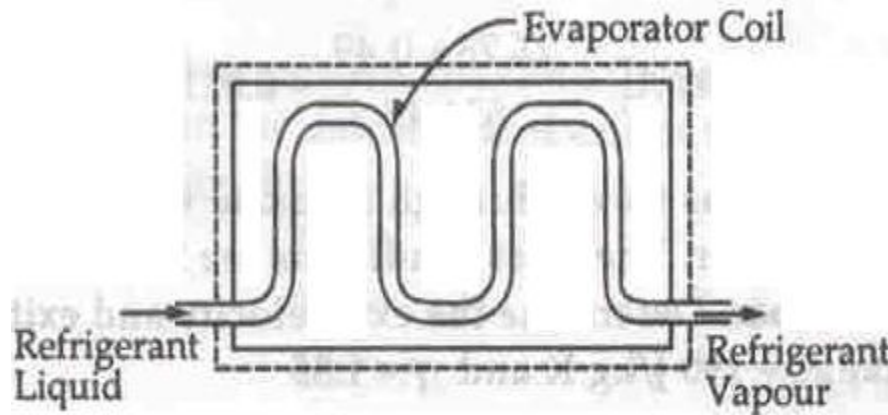

Figure: Evaporator

- v) **Boiler:** It is equipment used for the generation of the steam. Thermal energy released by combustion of fuel is transferred to water which vaporizes and gets converted into steam at the desired pressure and temperature. The steam thus generated is used for
- Producing mechanical work by expanding it in steam engine or steam turbine.
 - Heating the residential and industrial buildings in cold weather and
 - Performing certain processes in the sugar mills, chemical and textile industries.

1. Velocity change is negligible $V_1 = V_2$

2. Change in elevation is also negligible $Z_2 = Z_1$

3. Work done = 0

$$\therefore \text{SFEE is } h_1 + q = h_2$$

$$\therefore q = h_2 - h_1$$

$$= (u_2 - u_1) + (p_2 v_2 - p_1 v_1)$$

Problems:

1. 12 kg of a fluid per minute goes through a reversible steady flow process. The properties of fluid at the inlet are $p_1 = 1.4 \text{ bar}$, $\rho_1 = 25 \text{ kg/m}^3$, $V_1 = 120 \text{ m/s}$ & $u_1 = 920 \text{ kJ/kg}$ and at the exit are $p_2 = 5.6 \text{ bar}$, $\rho_2 = 5 \text{ kg/m}^3$, $V_2 = 180 \text{ m/s}$ and $u_2 = 720 \text{ kJ/kg}$. During the passage, the fluid rejects 60 kJ/s and raises through 60m. Determine i) the change in enthalpy ii) work done during the process.

Solution: i) Change in enthalpy $\Delta h = \Delta(u + pV)$

$$= (720 \times 10^3 - 920 \times 10^3) + (5.6 \times 10^5 \times 1/5 - 1.4 \times 10^5 \times 1/25) \\ = -93.6 \text{ kJ}$$

ii) SFEE for unit time basis is $\dot{Q} - \dot{W} = \dot{m}[\Delta h + \Delta KE + \Delta PE]$ --- (1)

$$\Delta KE = \frac{V_2^2 - V_1^2}{2} = \frac{180^2 - 120^2}{2} = 9000 \text{ J} = 9 \text{ kJ/kg}$$

$$\Delta PE = g(Z_2 - Z_1) = 9.81(60) = 0.589 \text{ kJ/kg}$$

\therefore Substituting in equation (1), $-60 - \dot{W} = 12/60 [-93.6 + 9 + 0.589]$

$$\therefore \dot{W} = -43.2 \text{ kW}$$

Negative sign indicates work is done on the fluid in the reversible steady flow process.

2. In the turbine of a gas turbine unit the gases flow through the turbine at 17 kg/s and the power developed by the turbine is 14000 kW. The enthalpies of the gases at inlet and outlet are 1200 kJ/kg and 360 kJ/kg respectively, and the velocities of the gases at inlet and outlet are 60 m/s and 150 m/s respectively. Calculate the rate at which the heat is rejected from the turbine. Find also the area of the inlet pipe given that the specific volume of the gases at inlet is $0.5 \text{ m}^3/\text{kg}$.

Solution: $\dot{m} = 17 \text{ kg/s}$ $v_1 = 0.45 \text{ m}^3/\text{kg}$

$$P = 14000 \text{ kW} \quad \therefore \text{Work done } W = \frac{14000}{17} = 823.53 \text{ kJ/kg}$$

$$h_1 = 1200 \text{ kJ/kg} \quad h_2 = 360 \text{ kJ/kg} \quad V_1 = 60 \text{ m/s} \quad V_2 = 150 \text{ m/s}$$

We have SFEE, $Q - W = \Delta h + \Delta PE + \Delta KE$

$$\therefore \Delta KE = \frac{V_2^2 - V_1^2}{2} = 9.45 \text{ kJ/kg}$$

$$\Delta h = h_2 - h_1 = -840 \text{ kJ/kg}$$

$$\Delta PE = 0$$

Substituting in SFEE equation,

$$\therefore Q - 823.53 = -840 + 0 + 9.45$$

$$\therefore Q = -7.02 \text{ kJ/kg}$$

i.e., heat rejected = $7.02 \times 17 = 119.34 \text{ kW}$

$$\text{Also, we have } \dot{m} = \rho_1 A_1 V_1 = \frac{1}{v_1} A_1 V_1$$

$$17 = \frac{1}{0.5} A_1 (60) \quad \therefore A_1 = 0.142 \text{ m}^2$$

3. Air flows steadily at the rate of 0.4 kg/s through an air compressor entering at 6 m/s with a pressure of 1 bar and a specific volume of 0.85 m³/kg, and leaving at 4.5 m/s with a pressure of 6.9 bar and a specific volume of a 0.16 m³/kg. The internal energy of air leaving is 88 kJ/kg greater than that of the air entering. Cooling water in a jacket surrounding the cylinder absorbs heat from the air at the rate of 59 kJ/s. Calculate the power required to drive the compressor and the inlet and outlet pipe cross sectional areas.

Solution: $\dot{m} = 0.4 \text{ kg/s}$ $V_1 = 6 \text{ m/s}$ $p_1 = 1 \times 10^5 \text{ Pa}$
 $v_1 = 0.85 \text{ m}^3/\text{kg}$ $V_2 = 4.5 \text{ m/s}$ $P_2 = 6.9 \times 10^5 \text{ Pa}$ $v_2 = 0.16 \text{ m}^3/\text{kg}$
 $\Delta u = 88 \text{ kJ/kg}$ $Q = -59 \text{ kJ/s}$ $\dot{W} = ?$
 $\Delta p v = 6.9 \times 10^5 \times 0.16 - 1 \times 10^5 \times 0.85 = 25.4 \text{ kJ/kg}$
 $\Delta u = 88 \text{ kJ/kg}$
 $\therefore \Delta h = \Delta (u + p v) = 113.4 \text{ kJ/kg}$

SFEE for unit time basis is given by,

$$\dot{Q} - \dot{W} = \dot{m}[\Delta h + \Delta KE + \Delta PE]$$

$$\Delta KE = \frac{V_2^2 - V_1^2}{2} = -7.88 \text{ J/kg}$$

$$\Delta PE = 0$$

Substituting in the SFEE equation,

$$-59 - \dot{W} = 0.4 \left[113.4 - \frac{7.88}{1000} + 0 \right]$$

$$\therefore \dot{W} = -104.4 \text{ kW}$$

Negative sign indicates work is done in the air compressor i.e., power input to the compressor.

ii) We have $\dot{m} = \rho_1 A_1 V_1 = \rho_2 A_2 V_2$
 $= \frac{1}{v_1} A_1 V_1 = \frac{1}{v_2} A_2 V_2$

$$\therefore A_1 = \frac{\dot{m} v_1}{V_1} = 0.057 \text{ m}^2$$

$$A_2 = \frac{\dot{m} v_2}{V_2} = 0.0142 \text{ m}^2$$

4. A turbine operating under steady flow conditions receives steam at the following state. pressure 13.8 bar, specific volume 0.143 m³/kg, i.e., 2590 kJ/kg, velocity 30 m/s. The state of the steam leaving the turbine is pressure 0.35 bar, specific volume 4.37 m³/kg, i.e., 2360 kJ/kg, velocity 90

m/s. Heat is lost to the surroundings at the rate of 0.25 kJ/s. If the rate of steam flow is 0.38 kg/s, what is the power developed by the turbine? (102.8 kW).

5. At the inlet to a certain nozzle the enthalpy of the fluid is 3025 kJ/kg and the velocity is 60 m/s. At the exit from the nozzle the enthalpy is 2790 kJ/kg. The nozzle is horizontal and there is negligible heat loss from it. i) Find the velocity at the nozzle exit. ii) If the inlet area is 0.1 m² and specific volume at inlet is 0.19 m³/kg, find the rate of flow of fluid. iii) If the specific volume at the nozzle exit is 0.5 m³/kg, find the exit area of the nozzle.

Solution: $h_1 = 3025 \text{ kJ/kg}$ $V_1 = 60 \text{ m/s}$ $h_2 = 2790 \text{ kJ/kg}$ $Z_2 = Z_1$ $Q = 0$

SFEE is $Q - W = \Delta h + \Delta PE + \Delta KE$

For a nozzle, $W = 0$, $Q = 0$, $\Delta PE = 0$

Substituting in SFEE, we get

$$\therefore \Delta h = \frac{V_1^2 - V_2^2}{2} \text{ i.e., } h_2 - h_1 = \frac{V_1^2 - V_2^2}{2}$$

$$\text{or } 2(h_2 - h_1) = V_1^2 - V_2^2 \therefore V_2 = \sqrt{V_1^2 - 2(h_2 - h_1)}$$

$$= 688.2 \text{ m/s}$$

ii) $\dot{m}_1 = \rho_1 A_1 V_1$

$$= \frac{1}{v_1} \cdot A_1 V_1 = \frac{1}{0.19} (0.1) (60) = 31.6 \text{ kg/s}$$

iii) $\dot{m}_2 = \rho_2 A_2 V_2$

$$31.6 = \frac{1}{0.5} \cdot A_2 (688.2) \therefore A_2 = 0.0229 \text{ m}^2$$

6. In a steam power plant 1.5 kg of water is supplied per second to the boiler. The enthalpy and velocity of water entering the boiler are 800 kJ/kg and 10 m/s. Heat at the rate of 2200 kJ/kg of water is supplied to the water. The steam after passing through the turbine comes out with a velocity of 50 m/s and enthalpy of 2520 kJ/kg. The boiler inlet is 5m above the turbine exit. The heat loss from the boiler is 1800 kJ/min and from the turbine 600 kJ/min. Determine the power capacity of the turbine, considering boiler and turbine as single unit.

Solution: $\dot{m} = 1.5 \text{ kg/s}$ $h_1 = 800 \text{ kJ/kg}$ $V_1 = 10 \text{ m/s}$ $Q = 2200 \text{ kJ/kg}$
 $V_2 = 50 \text{ m/s}$ $h_2 = 2520 \text{ kJ/kg}$ $Z_1 = 5 \text{ m}$ $Z_2 = 0$ $W = ?$

Heat loss from boiler and turbine is $1800 + 600 = 2400 \text{ kJ/min}$

$$= 40 \text{ kJ/sec} = \frac{40}{1.5} = 26.67 \text{ kJ/kg}$$

Net heat added to the water in the boiler $Q = 2200 - 26.67 = 2173.33 \text{ kJ/kg}$

SFEE is $Q - W = \Delta h + \Delta KE + \Delta PE$ --- (1)

$$\Delta h = h_2 - h_1 = 2500 - 800 = 1720 \text{ kJ/kg}$$

$$\Delta KE = \frac{V_2^2 - V_1^2}{2} = \frac{50^2 - 10^2}{2} = 1200 \text{ J/kg} = 1.2 \text{ kJ/kg}$$

$$\Delta PE = g(Z_2 - Z_1) = 9.81(0 - 5) = -49.05 \text{ J/kg} = -49.05 \times 10^{-3} \text{ kJ/kg}$$

$$\therefore \text{Substituting in (1), } 2173.33 - W = 1720 + 1.2 - 49.05 \times 10^{-3}$$

$$\therefore W = 452.18 \text{ kJ/kg}$$

$$\therefore \text{Power capacity of the turbine } P = 452.18 \times 1.5 = 678.27 \text{ kW}$$

7. A centrifugal air compressor used in gas turbine receives air at 100 KPa and 300 K and it discharges air at 400 KPa and 500 K. The velocity of air leaving the compressor is 100 m/s. Neglecting the velocity at the entry of the compressor, determine the power required to drive the compressor if the mass flow rate is 15 kg/sec. Take $C_p(\text{air}) = 1 \text{ kJ/kgK}$, and assume that there is no heat transfer from the compressor to the surroundings.

$$\text{Solution: } p_1 = 100 \times 10^3 \text{ N/m}^2 \quad T_1 = 300 \text{ K} \quad p_2 = 400 \times 10^3 \text{ N/m}^2 \quad T_2 = 500 \text{ K}$$

$$V_2 = 100 \text{ m/s} \quad W = ? \quad \dot{m} = 15 \text{ kg/s} \quad C_p = 1 \text{ kJ/kgK} \quad Q = 0$$

$$\text{SFEE is } Q - W = \Delta h + \Delta KE + \Delta PE$$

$$\begin{aligned} \Delta h &= \dot{m} C_p (T_2 - T_1) = 15 (1) (500 - 300) \\ &= 3000 \text{ kJ/s} = 3000 / 15 = 200 \text{ kJ/kg} \end{aligned}$$

$$\Delta KE = \frac{V_2^2}{2} = \frac{100^2}{2} = 5000 \text{ J/kg} = 5 \text{ kJ/kg}$$

Substituting in SFEE we have

$$0 - W = 200 + 5 = 205 \text{ kJ/kg}$$

$$\text{i.e., } W = -205 \text{ kJ/kg} = -205 \times 15 \text{ kJ/s} = -3075 \text{ kW}$$

Negative sign indicates work is done on the centrifugal air compressor

$$\therefore \text{Power required} = 3075 \text{ kW}$$

8. In a water cooled compressor 0.5 kg of air is compressed/sec. A shaft input of 60 kW is required to run the compressor. Heat lost to the cooling water is 30% of input and 10% of the input is lost in bearings and other frictional effects. Air enters the compressor at 1 bar and 20°C. Neglecting the changes in KE & PE, determine the exit air temperature. Take $C_p = 1 \text{ kJ/kg}^\circ\text{C}$ air.

$$\text{Solution: } \dot{m} = 0.5 \text{ kg/s} \quad W = 60 \text{ kW} \quad H_L = (30\% + 10\%) \text{ input} = 40\% \text{ input}$$

$$p_1 = 1 \times 10^5 \text{ N/m}^2 \quad t_1 = 20^\circ\text{C}$$

$$\text{SFEE is } Q - W = \Delta h + \Delta KE + \Delta PE$$

$$\Delta KE = 0, \Delta PE = 0$$

$$W = 60 \text{ kW} = 60 \text{ kJ/sec} = \frac{60}{0.5} = 120 \text{ kJ/kg}$$

$$\begin{aligned} \text{Heat lost to the surroundings} &= 40\% (\text{input}) = 0.4 (120) \\ &= 48 \text{ kJ/kg} \end{aligned}$$

Substituting in SFEE we have

$$-48 - (-120) = \Delta h$$

$$\text{But } \Delta h = C_p (t_2 - t_1)$$

$$\therefore -48 + 120 = C_p (t_2 - t_1)$$

$$\text{i.e., } 72 = 1 (t_2 - 20)$$

$$\therefore t_2 = 92^\circ\text{C}$$

9. A petrol engine develops 50 kW brake power. The fuel and air flow rates are 10 kg and 107 kg/hr. The temperature of fuel air mixture entering the engine is 20°C and temperature of gases leaving the engine is 500°C. The heat transfer rate from the engine to the cooling water circulated is 50kJ/s and that to the surroundings 10 kJ/s. Evaluate the increase in the specific enthalpy of the mixture as it flows through the engine.

Solution: $W = 50 \text{ kW} = 50 \text{ kJ/s} = 1538.46 \text{ kJ/kg}$ $\dot{m} = (10 + 107)\text{kg/hr} = 0.0325 \text{ kg/s}$
 $t_1 = 20^\circ\text{C}$ $t_2 = 500^\circ\text{C}$ $Q_L = 50 + 10 = 60 \text{ kJ/s} = 1846.15 \text{ kJ/kg}$

SFEE is $Q_L - W = \Delta h + \Delta KE + \Delta PE$ but $\Delta KE = \Delta PE = 0$

Substituting in SFEE, we have

$$- 1846.15 - 1538.46 = \Delta h$$

$$\therefore \Delta h = - 3384.61 \text{ kJ/kg}$$

$$= - 109.99 \text{ kJ/sec}$$

Negative sign indicates there is decrease in enthalpy of the mixture.

10. Air at a temperature of 15°C passes through a heat exchanger at a velocity of 30 m/s where its temperature is raised to 800°C. It then enters a turbine with the same velocity of 30 m/s and expands until the temperature falls to 650°C. On leaving the turbine, the air is taken at a velocity of 60 m/s to a nozzle where it expands until the temperature has fallen to 500°C. If the air flow rate is 2 kg/s, calculate i) the rate of heat transfer to the air, ii) the power output from the turbine assuming no heat loss, and iii) the velocity at exit from the nozzle, assuming no heat loss. Take the enthalpy of air as $h = C_p t$, where $C_p = 1.005 \text{ kJ/kg}^\circ\text{C}$.

Solution: $t_1 = 15^\circ\text{C}$, $V_1 = 30 \text{ m/s}$, $t_2 = 800^\circ\text{C}$ $V_2 = 30 \text{ m/s}$ $t_3 = 650^\circ\text{C}$
 $V_3 = 60 \text{ m/s}$ $t_4 = 500^\circ\text{C}$ $\dot{m} = 2 \text{ kg/s}$

i) Heat exchanger: $Q = ?$

$$Q - W = (\Delta h + \Delta KE + \Delta PE) \text{ but } \Delta KE = \Delta PE = 0$$

$$\therefore Q = C_p (t_2 - t_1)$$

$$= 1.005 (800 - 15) = 788.93 \text{ kJ/kg}$$

$$\text{or } Q = 1577.85 \text{ kJ/s}$$

ii) Turbine: $W = ?$

$$Q - W = \Delta h + \Delta KE + \Delta PE, \text{ but } Q = 0, \Delta PE = 0$$

$$\Delta h = C_p (t_3 - t_2) = (650 - 800) 1.005 = - 150.75 \text{ kJ/kg}$$

$$\Delta KE = \frac{V_3^2 - V_2^2}{2} = \frac{60^2 - 30^2}{2} = 1350 \text{ J/kg} = 1.35 \text{ kJ/kg}$$

Substituting in SFEE, we have

$$\therefore - W = - 150.75 + 1.35$$

$$\therefore W = 149.4 \text{ kJ/kg}$$

$$= 149.4 \times 2 = 298.8 \text{ kW}$$

iii) Nozzle: $V_4 = ?$

$$Q - W = \Delta h + \Delta KE + \Delta PE, \text{ but } Q = 0, W = 0, \Delta PE = 0$$

Substituting in SFEE, we have

$$(h_3 - h_4) = \frac{V_4^2 - V_3^2}{2}$$

i.e., $2C_p (t_3 - t_4) = V_4^2 - V_3^2$

$$\therefore 2 (1.005) (650 - 500) + 60^2 = V_4^2$$

$$\therefore V_4 = 552.36 \text{ m/s}$$

11. A 260 mm dia cylinder fitted with a frictionless leak proof piston contains 0.02 kg of steam at a pressure of $6 \times 10^5 \text{ N/m}^2$ and a temperature of 200°C . As the piston moves slowly outwards through a distance of 305 mm the steam undergoes a fully resisted expansion according to the law $pV^n = \text{constant}$ to a final pressure $1 \times 10^5 \text{ N/m}^2$. Determine i) value of the index n ii) work done by the steam iii) Magnitude and sign of heat transfer.

Solution: $d = 0.26 \text{ m}$, $m = 0.02 \text{ kg}$ $p_1 = 6 \times 10^5 \text{ Pa}$ $t_1 = 200^\circ\text{C}$
 $l = 0.305 \text{ m}$, $pV^n = C$ $p_2 = 1 \times 10^5 \text{ Pa}$

$$\text{Stroke volume} = \frac{\pi}{4} d^2 l = \frac{\pi}{4} (0.26)^2 (0.305) = 0.016193 \text{ m}^3$$

Considering steam as a perfect gas, $p_1 V_1 = mRT_1$,

$$\therefore V_1 = \frac{0.02 (287) (473)}{6 \times 10^5} = 4.525 \times 10^{-3} \text{ m}^3$$

$$\begin{aligned} \therefore \text{Final volume} = V_2 &= V_1 + \text{stroke volume} \\ &= 4.525 \times 10^{-3} + 0.016193 \\ &= 0.020693 \text{ m}^3 \end{aligned}$$

i) $n = ?$ $p_1 V_1^n = p_2 V_2^n$

$$\text{or } \frac{p_1}{p_2} = \left(\frac{V_2}{V_1} \right)^n \quad \text{i.e., } \frac{6 \times 10^5}{1 \times 10^5} = \left(\frac{0.020693}{4.525 \times 10^{-3}} \right)^n \quad \therefore n = 1.179$$

ii) $\text{Work done} = \frac{p_1 V_1 - p_2 V_2}{n - 1} = 3.607 \text{ kJ}$

iii) For reversible polytropic process,

$$Q = \left(\frac{\gamma - n}{n - 1} \right) W = \left(\frac{1.4 - 1.179}{0.179} \right) 3.607 = 4.453 \text{ kJ}$$

12. Air flows steadily at the rate of 0.5 kg/s through an air compressor, entering at 7 m/s velocity, 100 KPa pressure, $0.95 \text{ m}^3/\text{kg}$ volume, and leaving at 5 m/s velocity, 700 KPa pressure and $0.19 \text{ m}^3/\text{kg}$. The internal energy of the air leaving is 93 kJ/kg greater than that of the air entering. Cooling water in the compressor jackets absorbs heat from the air at the rate of 58 kW. i) compute the rate of shaft work in kW ii) find the ratio of the inlet pipe dia to outlet pipe diameter.

Solution: $\dot{m} = 0.5 \text{ kg/s}$ $V_1 = 7 \text{ m/s}$ $p_1 = 100 \times 10^3 \text{ Pa}$ $V_1 = 0.95 \text{ m}^3/\text{kg}$

$$V_2 = 5 \text{ m/s} \quad p_2 = 700 \times 10^3 \text{ Pa} \quad v_2 = 0.19 \text{ m}^3/\text{kg} \quad (u_2 - u_1) = 93 \text{ kJ/kg}$$

$$Q_L = 58 \text{ kJ/s} = \frac{58}{0.5} = 116 \text{ kJ/kg} \quad Z_1 = Z_2$$

$$Q - W = \Delta h + \Delta KE + \Delta PE \quad \text{--- (1)}$$

$$\begin{aligned} \Delta h = \Delta(U + pV) &= (U_2 - U_1) + (p_2V_2 - p_1V_1) \\ &= 93 \times 10^3 + [700 \times 10^3 \times 0.19 - 100 \times 10^3 \times 0.95] \\ &= 131000 \text{ J/kg} = 131 \text{ kJ/kg} \end{aligned}$$

$$\Delta KE = \frac{V_2^2 - V_1^2}{2} = -12 \text{ J/kg} = -12 \times 10^{-3} \text{ kJ/kg}$$

$$\Delta PE = 0$$

$$\therefore \text{Equation (1) becomes, } -116 - W = 131 - 12 \times 10^{-3}$$

$$\begin{aligned} \therefore W &= -246.99 \text{ kJ/kg} \\ &= -246.99 \times 0.5 = -123.49 \text{ kW} \end{aligned}$$

Negative sign indicates shaft work done on the compressor.

$$\text{ii) } \dot{m} = \rho_1 A_1 V_1 = \rho_2 A_2 V_2$$

$$= \frac{A_1 V_1}{v_1} = \frac{A_2 V_2}{v_2} \therefore \frac{A_1}{A_2} = \frac{V_2 v_1}{V_1 v_2} = 3.5714$$

$$\frac{\frac{\pi}{4} d_1^2}{\frac{\pi}{4} d_2^2} = 3.5714 \quad \therefore \frac{d_1}{d_2} = 1.8898$$

13. A gas flows into a turbine with an initial pressure of 7 bar, specific volume 0.2 m^3 and velocity 150 m/s . The corresponding values of pressure, specific volume and velocity at the exit are 3.5 bar , 0.5 m^3 and 300 m/s respectively. During the expansion of gas in the turbine its internal energy decreases by 92 kJ/kg and loss due to radiation was 13 kJ/kg . What amount of shaft work is developed per kg of gas flow.

14. The compressor of a large gas turbine receives air from the surroundings at 95 KPa and 20°C . The air is compressed to 800 KPa according to the relation $pV^{1.3} = \text{constant}$. The inlet velocity is negligible and the outlet velocity is 100 m/s . The power input to the compressor is 2500 kW , 20% of which is removed as heat from the compressor. What is the mass flow rate of the air? Take $C_p = 1.01 \text{ kJ/kg}^\circ\text{K}$ for air.

$$\begin{aligned} \text{Solution: } p_1 &= 95 \times 10^3 \text{ N/m}^2 \quad T_1 = 293 \text{ K} \quad p_2 = 800 \times 10^3 \text{ N/m}^2 \\ pV^{1.3} &= C \quad V_2 = 100 \text{ m/s} \quad W = -2500 \text{ kW} \quad \dot{Q} = -0.2 (2500) = -500 \text{ kW} \\ \dot{m} &= ? \quad C_p = 1.01 \text{ kJ/kg}^\circ\text{K} \end{aligned}$$

$$\text{we have } \frac{T_2}{T_1} = \left(\frac{p_2}{p_1} \right)^{\frac{n-1}{n}} \quad \therefore T_2 = 293 \left(\frac{800}{95} \right)^{\frac{0.3}{1.3}} = 479.09^\circ\text{K}$$

$$\dot{Q} - \dot{W} = \dot{m} \Delta \left(h + \frac{V_2^2}{2} + gZ \right)$$

$$-500 + 2500 = \dot{m} \left[1.01(479.09 - 293) + \frac{100^2}{2} \times 10^{-3} \right]$$

$$\therefore \dot{m} = 10.365 \text{ kg/sec}$$

15. The steam supply to an engine is comprised of two streams which mix before entering the engine. One stream is supplied at the rate of 0.01 kg/s with an enthalpy of 2950 kJ/kg and a velocity of 20 m/s. The other stream is supplied at the rate of 0.1 kg/s with an enthalpy of 2569 kJ/kg and a velocity of 120 m/s. At the exit from the engine the fluid leaves as two streams, one of water at the rate of 0.001 kg/s with an enthalpy of 420 kJ/kg and the other of steam. The fluid velocity at the exit are negligible. The engine develops a shaft power of 25 kW. The heat transfer is negligible. Evaluate the enthalpy of the second exit stream. (Ans. 2462 kJ/kg)

16. A perfect gas flows through a nozzle where it expands in a reversible adiabatic manner. The inlet conditions are 22 bar, 500°C, 38 m/s. At exit the pressure is 2 bar. Determine the exit velocity and exit area if the flow rate is 4 kg/s. Take $R = 190 \text{ J/kg}\cdot\text{K}$ and $\gamma = 1.35$

[hint: $C_p = \frac{\gamma}{\gamma - 1} R$, $\Delta h = C_p(T_2 - T_1)$, $\frac{T_2}{T_1} = \left(\frac{p_2}{p_1} \right)^{\frac{\gamma - 1}{\gamma}}$

$$p_2 v_2 = RT_2 \quad \therefore v_2 = 0.3933 \text{ m}^3/\text{kg} \quad \therefore \rho_2 = \frac{1}{v_2} \quad \dot{m} = \rho_2 A_2 V_2 \quad]$$

Ans.: $V_2 = 726 \text{ m/s}$, $A_2 = 0.002167 \text{ m}^2$

17. A steam turbine operate under steady flow conditions receiving steam at the following state: Pressure 15 bar, internal energy 2700 kJ/kg, velocity 300 m/s, specific volume 0.17 m³/kg and velocity 100 m/s.

The exhaust of steam from the turbine is at 0.1 bar with internal energy 2175 kJ/kg, specific volume 15m³/kg and velocity 300 m/s. The intake is 3 m above the exhaust. The turbine develops 35 kW and heat loss over the surface of turbine is 20kJ/kg. Determine the steam flow rate through the turbine. [Ans.: 0.0614 kg/s]

18. Determine the power required to drive a pump which raises the water pressure from 1 bar at entry to 25 bar at exit and delivers 2000 kg/hr of water. Neglect changes in volume, elevation and velocity and assume specific volume of water to be 0.001045m³/kg.

Solution: We have $\dot{Q} - \dot{W} = \dot{m}[\Delta h + \Delta KE + \Delta PE]$

$\dot{Q} = 0$, $\Delta KE = 0$, $\Delta PE = 0$

Substituting in the SFEE equation,

$\Delta u = 0 \therefore$ Water does not experience any change in temperature

$$= \dot{m}v(p_2 - p_1) \quad \text{but } v_1 = v_2$$

$$\therefore \dot{W} = - 1.393 \text{ kW}$$

19. In a conference hall comfortable temperature conditions are maintained in winter by circulating hot water through a piping system. The water enters the piping system at 3 bar pressure and 50°C temperature (enthalpy = 240 kJ/kg) and leaves at 2.5 bar pressure and 30°C temperature (enthalpy = 195 kJ/kg). The exit from the piping system is 15 m above the entry. If 30 MJ/hr of heat needs to be supplied to the hall, make calculation for the quantity of water circulated through the pipe per minute. Assume that there are no pumps in the system and that the change in KE is negligible.

Solution: $Q - W = (\Delta h + \Delta KE + \Delta PE)$

$$W = 0, \Delta KE = 0$$

$$Q = (195 - 240) + \frac{9.81(15)}{1000}$$

$$= - 44.853 \text{ kJ/kg}$$

$$\therefore \text{Mass of water to be circulated} = \frac{30 \times 10^6}{44.853 \times 10^3 \times 60} = 11.15 \text{ kg/min}$$

Unsteady flow process: In a steady flow process we have assumed that the mass and energy within the system remain constant and do not vary with time. In an unsteady flow process, mass and energy within the control volume vary continuously. The fluid flow into and out of the system.

Example: Filling or evacuation of a tank, (internal energy as well as mass of the tank changes with time), the condition of water in the cylinder jacket of an I.C. engine (is time dependant)

Analysis: Consider the flow of a fluid through a pipe line into the cylinder. Let m_1 be the mass of the fluid initially in the cylinder at pressure p_1 , temperature t_1 and m_2 the final mass in the cylinder at pressure p_2 , temperature t_2 . The mass that flows into the cylinder is thus $(m_2 - m_1)$.

There are two ways for solving problems involving unsteady flow (i) Closed system analysis (ii) Control volume analysis

(i) **Closed system analysis:**

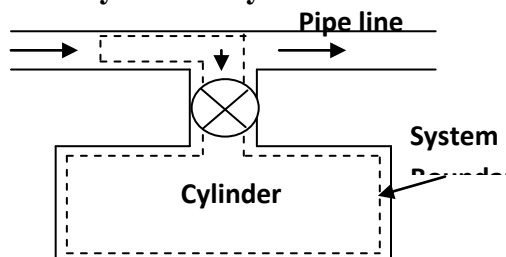

Since no mass crosses the boundary of the system, the boundary of the system is selected in such a way that it includes not only the cylinder but also that portion of the fluid in the pipe line which will be introduced eventually into the cylinder as shown in figure. That means the system has variable boundaries which at the final state will be the same as that of the cylinder. Initially energy of the system E_1 is composed of the internal energy of the mass initially in the cylinder, m_1u_1 plus the energy of the fluid which will eventually flow the pipe line into the cylinder, $(m_2 - m_1) \left[u_p + \frac{\bar{V}_p^2}{2} \right]$

where the subscript 'p' refers to the condition of the fluid in the pipe line. At the final state, energy E_2 of the fluid in the system will be equal to m_2u_2 .

Neglecting the change in PE, the change in energy is,

$$E_2 - E_1 = m_2u_2 - \left[m_1u_1 + (m_2 - m_1) \left\{ u_p + \frac{\bar{V}_p^2}{2} \right\} \right]$$

To find out work done on the system, consider a mass in the pipe line $(m_2 - m_1)$ which is subjected to a controlled pressure P_p . The flow work due to the flow of mass $(m_2 - m_1)$ into the cylinder from the $(m_2 - m_1) v_p$ in the pipe line to a zero volume is

$$W = P_p [0 - (m_2 - m_1) v_p] = - (m_2 - m_1) P_p v_p$$

Where v_p is the specific volume of the fluid in the pipeline.

Applying 1st law of thermodynamics,

$$Q + (m_2 - m_1)P_p v_p = m_2u_2 - \left[m_1u_1 + (m_2 - m_1) \left\{ u_p + \frac{\bar{V}_p^2}{2} \right\} \right]$$

But $h_p = u_p + P_p v_p$,

∴ Above equation becomes,

$$Q = m_2u_2 - m_1u_1 - (m_2 - m_1) \left[h_p + \frac{\bar{V}_p^2}{2} \right] \quad \text{--- (1)}$$

(ii) **Control Volume analysis:**

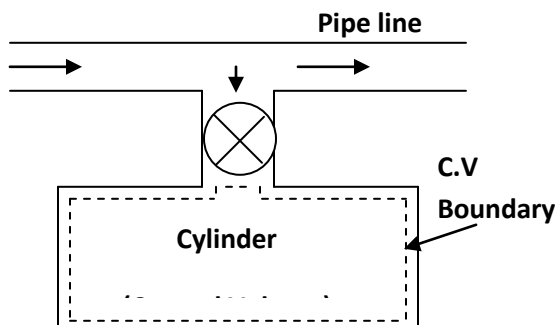

The cylinder itself is taken as the control volume as shown in figure. In this case, there is no work interaction. Using the general equation 1st law and considering no mass flows out of the control volume and neglecting the change in PE, as in the earlier case we have

$$\dot{Q} + (\dot{m}_2 - \dot{m}_1) \left[h_p + \frac{\bar{V}_p^2}{2} \right] = \frac{d}{d\tau} (U)_\sigma$$

$$\text{or } Q + (m_2 - m_1) \left[h_p + \frac{\bar{V}_p^2}{2} \right] = m_2 u_2 - m_1 u_1 \quad \text{--- (2)}$$

If the tank would have been thermally insulated and initially empty, $Q = 0$ and $m_1 = 0$ substituting into equation (1) and simplifying, we get $h_p + \frac{\bar{V}_p^2}{2} = u_2$ --- (3)

Also if KE in the pipe line is not appreciable, $h_p = u_2$ i.e., the specific enthalpy of the fluid in the pipe line is equal to the specific internal energy of the fluid in the cylinder at the final state.

Note: The tank emptying process is the reverse of filling process i.e., there is flow of fluid from the tank (cylinder) to the surroundings.

Analogous to filling process, applying 1st law, of thermodynamics, we have

$$Q = m_1 u_1 - m_2 u_2 - (m_1 - m_2) \left[h_p + \frac{\bar{V}_p^2}{2} \right] \quad \text{--- (4)}$$

Where h_p and V_p are the specific enthalpy and velocity of leaving fluid.

For no heat transfer and negligible exit velocity,

$$(m_1 - m_2) h_p = m_1 u_1 - m_2 u_2$$

Further if the tank is to be fully emptied ($m_2 = 0$)

$$\text{i.e., } m_1 h_p = m_1 u_1$$

$$\text{or } h_p = u_1$$

i.e., the specific enthalpy of the fluid in the cylinder is equal to the specific internal energy of the fluid in the pipe line at the final state.

Problems:

1. A household gas cylinder initially evacuated is filled by 15 kg gas supply of enthalpy 625 kJ/kg. After filling, the gas in the cylinder has the following parameters: pressure 10 bar, enthalpy 750 kJ/kg and specific volume 0.0487 m³/kg. Evaluate the heat received by the cylinder from the surroundings.

Solution: Given: $m_2 = 15$ kg $h_p = 625$ kJ/kg $P_2 = 10$ bar $h_2 = 750$ kJ/kg
 $v_2 = 0.0487$ m³/kg

SFEE to the filling process is

$$Q = m_2 u_2 - m_1 u_1 - (m_2 - m_1) \left[h_p + \frac{\bar{V}_p^2}{2} \right]$$

The cylinder is initially evacuated i.e., $m_1 = 0$, also $\bar{V}_p = 0$

$$\begin{aligned} \text{i.e., } Q &= m_2 u_2 - m_2 h_p \\ &= m_2 [(h_2 - p_2 v_2) - h_p] \\ &= 15 \left[\left(750 - \frac{10 \times 10^5 (0.0487)}{10^3} \right) - 625 \right] \\ &= 1144.5 \text{ kJ} \end{aligned}$$

2. An insulated and rigid tank contains 5 m^3 of air at 10 bar and 425 K. The air is then let off to atmosphere through a valve. Determine the work obtainable by utilizing the KE of the discharge air. Take $C_p = 1 \text{ kJ/kg K}$, $C_v = 0.714 \text{ kJ/kg}^\circ\text{-K}$ atmosphere pressure = 1 bar.

Solution: Given: $V_1 = V_2 = 5 \text{ m}^3$ $P_1 = 10 \text{ bar}$ $T_1 = 425 \text{ K}$

The situation corresponds to emptying process, for which the energy balance equation is,

$$Q + (m_1 - m_2) h_p + \frac{\bar{V}_p^2}{2} = m_1 u_1 - m_2 u_2$$

Insulated and rigid tank i.e., $Q = 0$

$$(m_1 - m_2) \left[h_p + \frac{\bar{V}_p^2}{2} \right] = m_1 u_1 - m_2 u_2 \quad \text{Suffix 'p' refers to discharge condition.}$$

$$\begin{aligned} \text{Or } (m_1 - m_2) \frac{\bar{V}_p^2}{2} &= m_1 u_1 - m_2 u_2 - (m_1 - m_2) h_p \\ &= m_1 C_v T_1 - m_2 C_v T_2 - (m_1 - m_2) C_p T_2 \quad \text{--- (1)} \end{aligned}$$

$$\text{We have, } \gamma = \frac{C_p}{C_v} = \frac{1}{0.714} \cong 1.4 \quad p_2 = 1 \text{ bar,} \quad R = C_p - C_v = 0.286 \text{ kJ/kg K}$$

$$\therefore \frac{T_2}{T_1} = \left(\frac{P_2}{P_1} \right)^{\frac{\gamma-1}{\gamma}} \quad \text{i.e., } T_2 = 425 \left(\frac{1}{10} \right)^{0.286} = 220 \text{ K}$$

$$\text{Also, } p_1 V_1 = m_1 R T_1 \quad \therefore m_1 = \frac{10 \times 10^5 \times 5}{286(425)} = 41.14 \text{ kg}$$

$$\& p_2 V_2 = m_2 R T_2 \quad \therefore m_2 = \frac{1 \times 10^5 \times 5}{286(220)} = 7.95 \text{ kg}$$

Substitute in equation (1) on RHS, we have

$$(m_1 - m_2) \frac{\bar{V}_p^2}{2} = 41.14 (0.714) (425) - 7.95 (0.714) (220)$$

$$- (41.14 - 7.95) (1.0) (220)$$

$$= 3933.35 \text{ kJ}$$

3. A vessel of constant volume 0.3 m^3 contains air at 1.5 bar and is connected via a valve, to a large main carrying air at a temperature of 38°C and high pressure. The valve is opened allowing air to enter the vessel and raising the pressure there in to 7.5 bar. Assuming the vessel and valve to be thermally insulated, find the mass of air entering the vessel.

Solution: The situation corresponds to filling process, for which the energy balance equation is,

$$Q + (m_2 - m_1) \left[h_p + \frac{\bar{V}^2}{2} \right] = m_2 u_2 - m_1 u_1$$

With thermally insulated and neglecting KE of air,

$$(m_2 - m_1) h_p = m_2 u_2 - m_1 u_1$$

$$\text{or } (m_2 - m_1) C_p T_p = m_2 C_v T_2 - m_1 C_v T_1$$

Air is a perfect gas, i.e., $pV = mRT$

$$\text{i.e., } m_2 T_2 = \frac{p_2 V}{R} \quad \text{and} \quad m_1 T_1 = \frac{p_1 V}{R} \quad \text{Given } V_1 = V_2 = V$$

$$\therefore (m_2 - m_1) C_p T_p = C_v \frac{V}{R} (p_2 - p_1)$$

$$\begin{aligned} \text{or } (m_2 - m_1) &= \frac{1}{T_p} \cdot \frac{1}{r} \cdot \frac{V}{R} (p_2 - p_1) \\ &= \frac{1}{311} \cdot \frac{1}{1.4} \cdot \frac{0.3}{287} (7.5 - 1.5) 10^5 \\ &= 1.44 \text{ kg} \\ &= \text{Mass of the air entering} \end{aligned}$$

4. After the completion of exhaust stroke of an I.C. engine the piston cylinder assembly remains filled up with $1 \times 10^{-4} \text{ kg}$ of combustible products at 800 K. During the subsequent suction stroke, the piston moves outward and $16 \times 10^{-4} \text{ kg}$ of air at 290 K is sucked inside the cylinder. The suction process occurs at constant pressure and heat interaction is negligible. Evaluate the temperature of gases at the end of suction stroke. For air and gases, take $C_p = 1 \text{ kJ/kg}$

Solution: The energy equation for the filling process is,

$$Q + (m_2 - m_1) \left[h_p + \frac{\bar{V}^2}{2} \right] = m_2 u_2 - m_1 u_1 + W$$

With no heat interaction and negligible KE of air in the supply line, above equation reduces to,

$$(m_2 - m_1) h_p = m_2 u_2 - m_1 u_1 + W$$

The suction occurs at constant pressure i.e., $W = \int_1^2 p dV = p(V_2 - V_1)$

$$= p (m_2 v_2 - m_1 v_1)$$

$$= m_2 (p_2 v_2 - p_1 v_1)$$

Substituting in the above equation for W , we have

$$\begin{aligned}(m_2 - m_1) h_p &= m_2 u_2 - m_1 u_1 + m_2 (p_2 v_2 - p_1 v_1) \\ &= m_2 (u_2 + p_2 v_2) - m_1 (u_1 + p_1 v_1) \\ &= m_2 h_2 - m_1 h_1\end{aligned}$$

$$\text{Or } (m_2 - m_1) C_p T_p = m_2 C_p T_2 - m_1 C_p T_1$$

$$\text{Or } (m_2 - m_1) T_p = m_2 T_2 - m_1 T_1$$

Substitute the given data, we get

$$(16 \times 10^{-4} - 1 \times 10^{-4}) 290 = 16 \times 10^{-4} \times T_2 - 1 \times 10^{-4} \times 800$$

$$T_2 = 321.87 \text{ K (Temperature of gas at the end of suction stroke)}$$

5. An air receiver of volume 6 m^3 contains air at 15 bar and 40.5°C . A valve is opened and some air is allowed to blow out to atmosphere. The pressure of the air in the receiver drops rapidly to 12 bar when the valve is then closed. Calculate the mass of air which has left the receiver.

Solution: The situation correspond to emptying process for which the energy balance equation is,

$$Q + (m_1 - m_2) \left[h_p + \frac{\bar{V}_p^2}{2} \right] = m_1 u_1 - m_2 u_2$$

But $Q = 0$, $V_p = 0$

$$\text{i.e., } (m_1 - m_2) h_p = m_1 u_1 - m_2 u_2$$

$$\text{Or } (m_1 - m_2) C_p T_p = m_1 C_v T_1 - m_2 C_v T_2$$

$$\text{From perfect gas equation, } p_1 V_1 = m_1 R T_1 \quad \text{i.e., } m_1 T_1 = \frac{p_1 V}{R}, \quad \text{Similarly } m_2 T_2 = \frac{p_2 V}{R}$$

\therefore Above equation becomes,

$$(m_1 - m_2) = \frac{C_v}{C_p T_p} \cdot \frac{V}{R} (p_1 - p_2)$$

$$\text{i.e., Mass of air left the receiver, } (m_1 - m_2) = \frac{1}{\gamma T_p} \cdot \frac{V}{R} (p_1 - p_2)$$

$$= \frac{1}{1.4(313.5)} \cdot \frac{6}{287} (15 - 12) 10^5$$

$$= 14.3 \text{ kg}$$

$$\text{Also, } m_1 = \frac{p_1 V_1}{R T_1} = 100.03 \text{ kg}$$

$$\therefore m_2 = 85.74 \text{ kg}$$

6. The internal energy of air is given, at ordinary temperature by, $u = u_0 + 0.718t$. Where u is in kJ/kg, u_0 is any arbitrary value of u at 0°C , kJ/kg and t is temperature in $^\circ\text{C}$. Also for air, $p v = 0.287 (t + 273)$ where p is in KPa and v is in m^3/kg .

- i) An evacuated bottle is fitted with a valve through which air from the atmosphere, at 760 mm oxygen and 25°C , is allowed to flow slowly to fill the bottle. If no heat transfer to or from the air in the bottle, what will its temperature be when the pressure in the bottle reaches 760 mm Hg?

- ii) If the bottle initially contains 0.03 m^3 of air at 400 mm Hg and 25°C , what will the temperature be when the pressure in the bottle reaches 760 mm of Hg ?

Solution: $u = u_0 + 0.718t$

$$pv = 0.287 (t + 273)$$

Using above equation determine C_v , C_p i.e., $C_v = du/dt = 0.718 \text{ kJ/kg} \cdot ^\circ\text{K}$

$$\& \quad C_p = \frac{dh}{dt} = \frac{d}{dt}(u + pv) = 1.005 \text{ kJ/kg} \cdot ^\circ\text{K}$$

- i) Situation corresponds to filling process, for which the energy balance equation is,

$$Q + (m_2 - m_1) \left[h_p + \frac{\bar{V}^2}{2} \right] = m_2 u_2 - m_1 u_1$$

Heat transfer $Q = 0$, evacuated bottle, $m_1 = 0$ and negligible KE, $V_p = 0$

$$\therefore m_2 h_p = m_2 u_2$$

Or $h_p = u_2$

i.e., $C_p T_p = C_v T_2$

$$\therefore T_2 = \frac{C_p}{C_v} T_p$$

$$= \gamma T_p = 1.4 (298)$$

$$= 417.12^\circ\text{K} \quad \text{or } 144.12^\circ\text{C}$$

- ii) Energy balance equation is, $(m_2 - m_1) h_p = m_2 u_2 - m_1 u_1$

i.e., $(m_2 - m_1) C_p T_p = m_2 C_v T_2 - m_1 C_v T_1$

Using perfect gas equation, $p_1 V_1 = m_1 R T_1$

But $p_1 = \omega h$

$$= 9810 (13.6) (400 \times 10^{-3}) = 53366.4 \text{ N/m}^2$$

$$\therefore m_1 = \frac{53366.4(0.03)}{287(298)} = 0.0187 \text{ kg}$$

Similarly $p_2 V_2 = m_2 R T_2$

$$P_2 = \omega h = 9810 (13.6) (760 \times 10^{-3})$$

$$= 101396.2 \text{ N/m}^2$$

$$\therefore m_2 = \frac{101396.2(0.03)}{287(T_2)} \quad \therefore V_1 = V_2$$

$$= \frac{10.59}{T_2}$$

Substituting in energy balance equation,

$$\left(\frac{10.59}{T_2} - 0.0187 \right) 1005(298) = \frac{10.59}{T_2} (718)T_2 - 0.0187 (718) (298)$$

Solving, $T_2 = 344.92^\circ\text{K}$ or 71.92°C

7. The internal energy of air is given by $u = u_0 + 0.718 t$ also for air, $pv = 0.287 (t + 273)$. A mass of air is stirred by a paddle wheel in an insulated constant volume tank. The velocities due to stirring make a negligible contribution to the internal energy of the air. Air flows out through a small valve in the tank at a rate controlled to keep the temperature in the tank constant. At a certain instant the conditions are as follows: tank volume 0.12m^3 , pressure 1 MPa, temperature 150°C and power to paddle wheel 0.1 kW. Find the rate of flow of air out of the tank at this instant.

Solution: The energy balance equation for emptying process is,

$$Q - W_s + (m_1 - m_2) \left(h_p + \frac{\bar{V}_p^2}{2} \right) = m_1 u_1 - m_2 u_2$$

Insulated tank, $Q = 0$, there is no change in i.e., of air in the tank. Internal energy, $u = 0$ and $\text{KE} = 0$

∴ Above equation becomes,

$$- W_s + (m_1 - m_2) h_p = 0$$

$$\text{i.e., } (m_1 - m_2) = W_s/h_p$$

Or rate of flow of air out of the tank at this instant

$$= \frac{0.1}{1.005 (425)} \quad \because h_p = C_p T_p$$

$$= 2.3412 \times 10^{-4} \text{ kg/s}$$

$$= 0.843 \text{ kg/hr}$$

8. A certain water heater operates under steady flow conditions receiving 4.2 kg/s of water at 75°C temperature, enthalpy 314 kJ/kg. The water is heated by mixing with steam which is supplied to the heater at temperature 100°C and enthalpy 2676 kJ/kg. The mixture leaves the heater as liquid water at temperature 100°C and enthalpy 419 kJ/kg. How much steam must be supplied to the heater per hour.

Solution: Energy entering = energy leaving

$$\begin{aligned} \dot{Q} + \dot{m}_1 \left[h_1 + \frac{V_1^2}{2} + gZ_1 \right] + \dot{m}_2 \left[h_2 + \frac{V_2^2}{2} + gZ_2 \right] \\ = \dot{m}_3 \left[h_3 + \frac{V_3^2}{2} + gZ_3 \right] + \dot{W} \end{aligned}$$

By the nature of the process, $\dot{W} = 0$ $\Delta\text{KE} = 0$ $\Delta\text{PE} = 0$ $\dot{Q} = 0$

$$\text{i.e., } \dot{m}_1 h_1 + \dot{m}_2 h_2 = \dot{m}_3 h_3$$

$$4.2(314) + \dot{m}_2(2676) = (4.2 + \dot{m}_2)(419)$$

$$\dot{m}_2 \cong 0.196 \text{ kg/s}$$

$$= 705 \text{ kg/hr}$$

MODULE 3

SECOND LAW OF THERMODYNAMICS

The first law states that when a closed system undergoes a cyclic process, the cyclic integral of the heat is equal to the cyclic integral of the work. It places no restrictions on the direction of the heat and the work.

As no restrictions are imposed on the direction in which the process may proceed, the cycle may be reversed and it will not violate the first law.

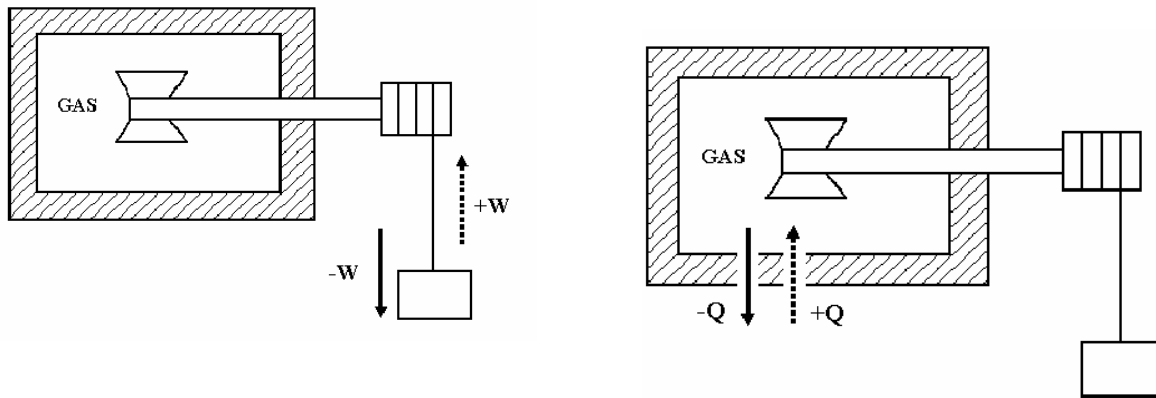
Example (1):

A closed system that undergoes a

In the example considered the system undergoes a cycle in which work is first done on the system by the paddle wheel as the weight is lowered. Then let the cycle be completed by transferring heat to the surrounding.

From experience it has been learnt that we cannot reverse this cycle. i.e., if we transfer heat to the gas, as shown by the dotted line, the temperature of the gas will increase, but the paddle wheel will not turn and lift the weigh. This system can operate in a cycle in which the heat and work transfers are both negative, but it cannot operate in a cycle when both are positive, even though this would not violate the first law.

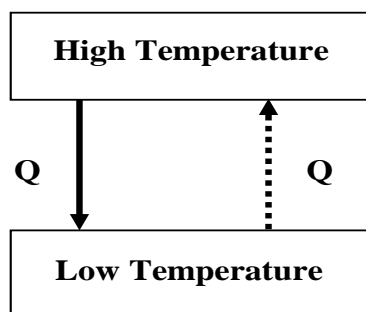
Example (2):

Let two systems, one at a high temperature and the other at a low temperature undergoes a process in which a quantity of heat is transferred from the high – temperature system to the low temperature system. From experience we know that this process can take place. But the reverse process in which heat is transferred from the low temperature system to the high temperature system does not occur and that it is

impossible to complete the cycle by heat transfer only.

These two examples lead us to the consideration of the heat engine and heat pump (i.e., refrigerator).

Experience tells us that the reversed processes described above do not happen. The total energy of each system would remain constant in the reversed process and thus there would be no violation of the first law. It follows that there must be some other natural principle in addition to the first law and not deducible from it, which governs the direction in which a process can take place in an isolated system. This principle is the Second law of thermodynamics.

Example (3) **Work of the mechanical form, can be converted completely into heat**

Consider the pushing of a block over a rough surface. The work used in pushing the block to overcome friction produces a heating effect on the block and the surface. To restore the temperature of the system to its original value, heat, equivalent in amount to the work input must be removed from the system. But from experience the converse of the operation is impossible. The heat that was removed will not of its own accord flow back into system, restore the block to its original position and deliver an amount of work equivalent to the original work input. Furthermore, heating the block will obviously not cause it to move, either.

The first law does not answer many questions (1) why there cannot be complete transformation of heat into work but work can be completely transformed into heat. (2) Why some processes can proceed in one direction but not in the other and the first law in no way explain, why it is possible for certain processes to take place but impossible for other processes to occur.

The second law does provide answers to these questions. The second law is broad and the heart of the second law is a property called **Entropy**.

Heat Engine:

Any device which converts heat into work. Consider a heat engine as a system which work in a thermodynamic cycle and converts a portion of the heat into the work, when the heat transfer occur from a body at higher temperature to a low temperature body. E.g., steam power plant, Thermocouple etc.

Gas turbines are also called heat engines though they do not work in a thermodynamic cycle

Steam power plant:

Let Q_H = Heat transferred from a high temperature reservoir like a furnace to the working fluid (water)

Q_L = Heat rejected from the steam to the low temperature reservoir like coolant in the condenser.

W = Amount of work done by the fluid during the cycle to run the generator or any other devices.

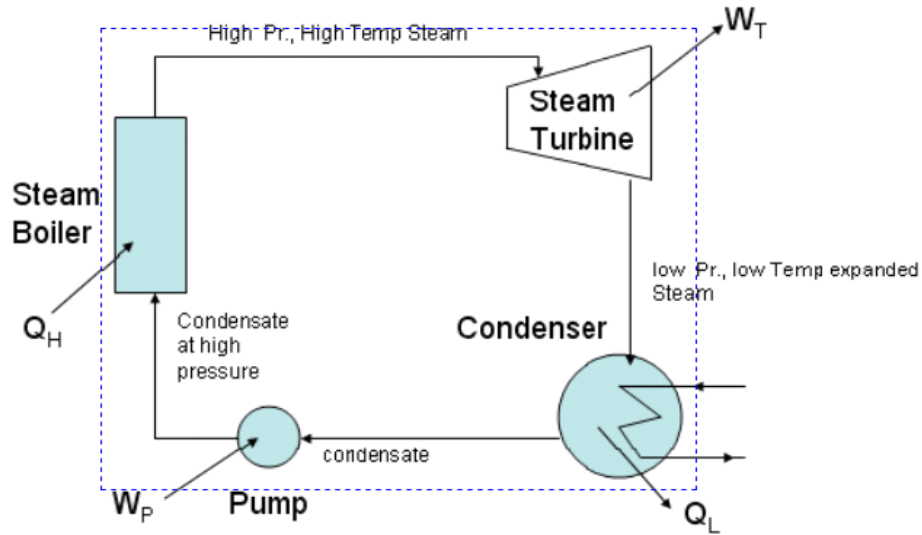

A steam turbine power plant

Thermal Efficiency (η_{th})

$$\eta_{th} = \frac{\text{Energy output}}{\text{Energy input}} = \frac{\text{Energy Sought for}}{\text{Energy that costs}}$$

$$= \frac{W}{Q_H} = \frac{Q_H - Q_L}{Q_H} = 1 - \frac{Q_L}{Q_H}$$

The first law has put no restriction by which the whole heat energy Q_H cannot be converted into work W , by reducing the transfer of heat to the low temperature reservoir to zero i.e., by reducing Q_L to zero. The η_{th} in that case would have 100%. But from experience such performance is impossible. During the process there will always be some loss of energy. This is also one of the limitation of the first law.

Refrigerator:

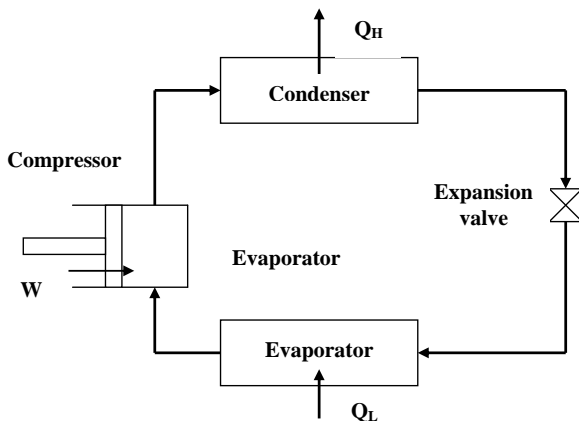

Heat cannot flow from a low temperature body to a high temperature body. But this can be done by providing external work to the system.

Consider a simple vapour compression system.

$W \rightarrow$ Amount of work done on the fluid (Refrigerant)

$Q_L \rightarrow$ Amount of heat that is transferred to the fluid (Refrigerant) in the evaporator (low temperature reservoir)

$Q_H \rightarrow$ Heat transferred from the fluid to the coolant in the condenser (High temperature reservoir)

The efficiency of a refrigerator is given by the term COP.

When the system works as refrigerator, the main interest is the net cooling effect Q_L for a refrigerator,

$$\begin{aligned} COP &= \frac{\text{Energy sought for}}{\text{Energy that costs}} = \frac{Q_L}{W} \\ &= \frac{Q_L}{Q_H - Q_L} \end{aligned}$$

When the system works as a heat pump, the main interest is the heat Q_H . Therefore for a heat pump.

$$COP = \frac{Q_H}{W} = \frac{Q_H}{Q_H - Q_L}$$

This illustration shows the limitation of the first law. From these we conclude that there must be some physical principle which though not derivable from the first law, directs the direction and extent up to which energy can be converted into one form to the other form. This principle is the second law of thermodynamics.

Second law like first law has no mathematical proof. It is based on the results of countless observations in nature.

PERPETUAL MOTION MACHINE OF FIRST KIND (PMMKI)

No machine can produce energy without corresponding expenditure of energy without corresponding expenditure of energy i.e., it is impossible to construct a PMMK of first kind. The machine violates the first law of thermodynamics. All attempts made so far to make PMMKI have failed, thus showing the validity of the first law.

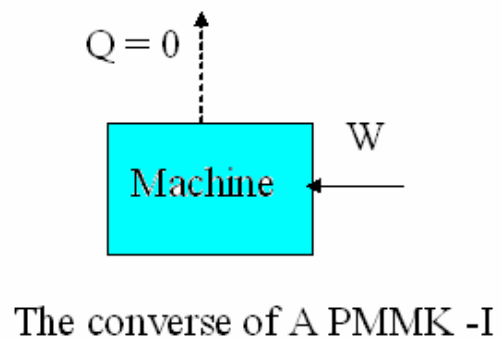
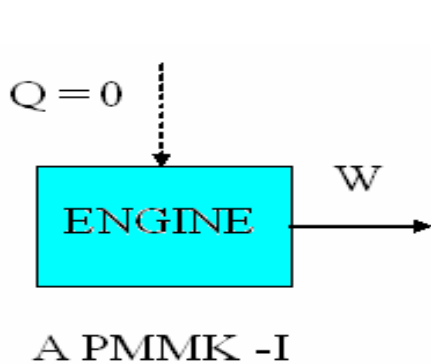

Second law of Thermodynamics

There are two classical statements of the second law of thermodynamics

- 1) Kelvin – Planck statement
- 2) Clausius statement

Kelvin – Planck statement

“It is impossible to construct a device which will operate in a cycle & produce no effect other than the raising of a weight and the exchange of heat with a single reservoir”

i.e., it is impossible to construct an engine which will operate in a cycle will produce no effect other than the transfer of heat from a single thermal reservoir and the performance of an equivalent amount of work”.

No actual or ideal engine operating in cycles can convert into work all the heat supplied to the working substance, it must discharge some heat into a naturally accessible sink because of this aspect and the second law is often referred as the law of degradation of energy.

The statement implies that it is impossible to construct a heat engine that working in a cyclic process can absorb an amount of heat from a high temperature reservoir and can do an equivalent amount of work. In other words it is not possible to construct a heat engine having thermal efficiency of 100 percent.

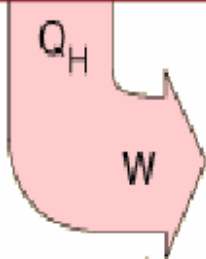

Extracting heat Q_H and using it all to do work W would constitute a perfect heat engine, forbidden by the second law.

IMPOSSIBLE

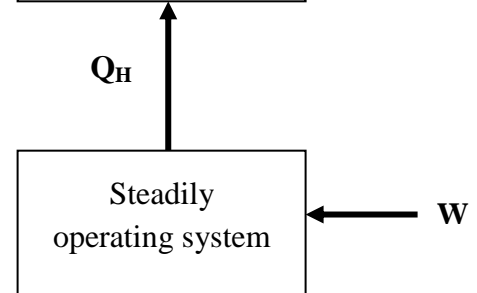
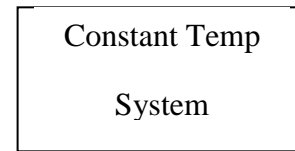

POSSIBLE

A directional implication of the 2nd Law

PERPETUAL MOTION MACHINE OF SECOND KIND (PMMKII)

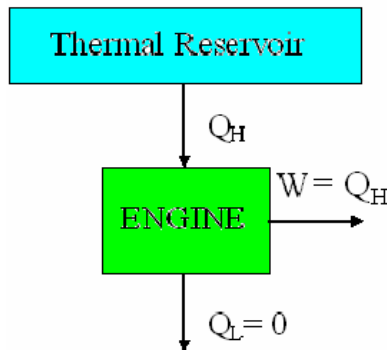

A PMMK -II

Without violating the first law a machine can be imagined which would continuously absorb heat from a single thermal reservoir and would convert this heat completely into work. The efficiency of such a machine would be 100%. This machine is called PMMK II. A machine of this kind will violate the second law of thermodynamics and hence does not exist.

Clausius Statement

It is impossible to construct a heat pump which operating in a cycle will produce no effect other than the transfer of heat from a low temperature thermal reservoir to a higher temperature thermal reservoir.

That is in order to transfer heat from a low temperature thermal reservoir to a high temperature thermal reservoir work must be done on the system by the surroundings.

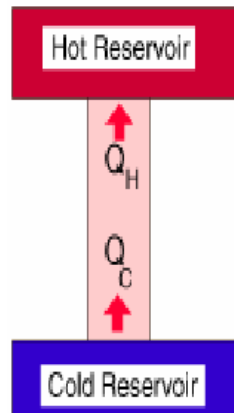

IMPOSSIBLE

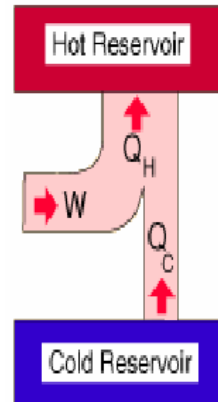

POSSIBLE

Although the Kelvin – Planck and Clausius statements appear to be different, they are really equivalent in the sense that a violation of one statement involves violation of the other.

Although the Kelvin – Planck and Clausius statements appear to be different, they are really equivalent in the sense that a violation of one statement involves violation of the other.

Proof of violation of the Kelvin – Planck statement results in violation of the Clausius statement.

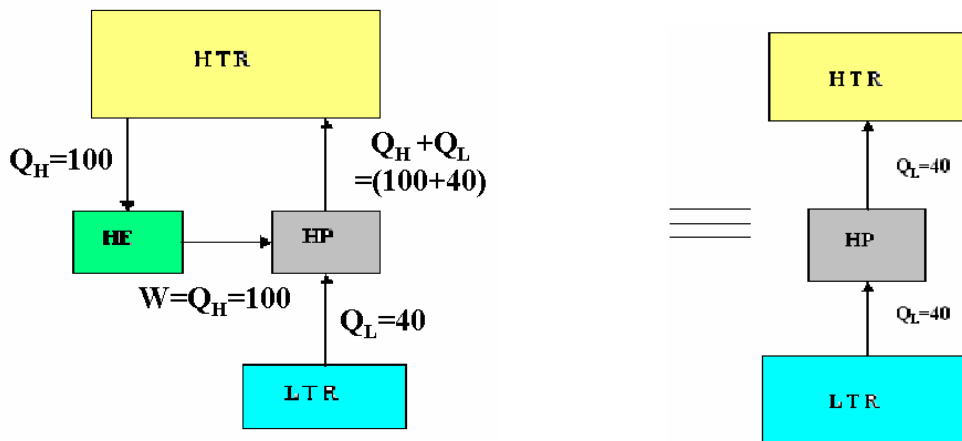

Consider a heat engine that is operating in a cyclic process takes heat (Q_H) from a high temperature reservoir & converts completely into work (W), violating the Kelvin – Planck statement.

Let the work W , which is equal to Q_H , be utilized to drive a heat pump as shown. Let the heat pump take in Q_L amount of heat from a low temperature reservoir and pump ($Q_H + Q_L$) amount of heat to the high temperature reservoir.

From the diagrams we see that a part of heat Q_H , pumped to the high temperature reservoir is delivered to the heat engine, while there remains a heat flow Q_L , from the low temperature reservoir to the high temperature reservoir, which in fact violates the Clausius statement.

Proof of violation of the Clausius statement results in violation of the Kelvin – Planck statement.

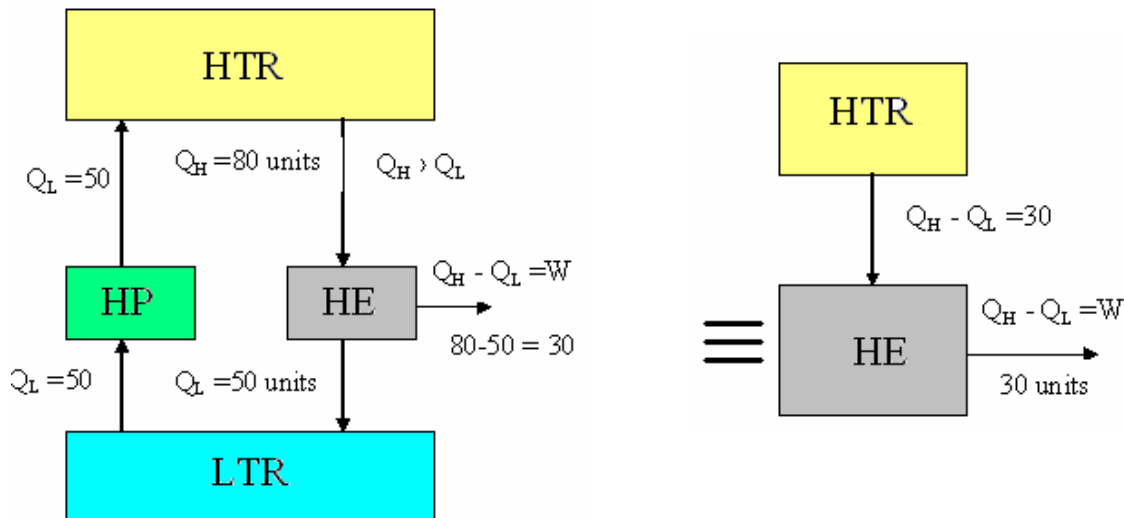

and

transfer the heat equivalent amount of heat Q_L to the HTR violating the Clausius statement.

Let an amount of heat Q_H , which is greater than Q_L , be transferred from high temperature reservoir to a heat engine, an amount of heat Q_L , be rejected by it to the LTR and an amount of work W which is equal to $(Q_H - Q_L)$ be done by the heat engine on the surrounding.

Since there is no change in heat transfer in the LTR, the heat pump, the HTR and the heat engine together can be considered as a device which absorbs an amount of heat $(Q_H - Q_L)$ from the HTR and produce an equal amount of work $W = Q_H - Q_L$ which in fact violates the Kelvin – Planck statement.

Reversibility and Irreversibility

If 100% efficiency is unattainable, what is the max possible efficiency which can be attained and what factors promote the attainment of this max value? In trying to answer these questions, thermodynamics has invented & used the concept of reversibility, absolute temperature and entropy.

Reversible Process:

-for a system is defined as a process which once having taken place, can be reversed and leaves no change in either the system or surroundings. Only ideal processes can do this and restore both system and surroundings to their initial states. Hence an ideal process must be a reversible process.

No real process is truly reversible but some processes may approach reversibility, to a close approximation.

Example:

- 1) Frictionless relative motion
- 2) Extension and compression of a spring
- 3) Frictionless adiabatic expansion or compression of fluid.
- 4) Polytropic expansion or compression etc.,

The conditions for a process to be reversible may be given as follows:

- i) There should be no friction
- ii) There should be no heat transfer across finite temperature difference.
- iii) Both the system and surrounding be stored to original state after the process is reversed.

Any process which is not reversible is irreversible.

Example: Movement of solids with friction, A flow of viscous fluid in pipes and passages mixing of two different substances, A combustion process.

Every quasistatic process is reversible, because a quasistatic process is of an infinite succession of equilibrium states.

Examples of Irreversible processes:

(i) Solid Friction

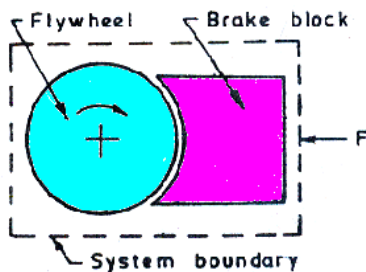

(ii) Free expansion

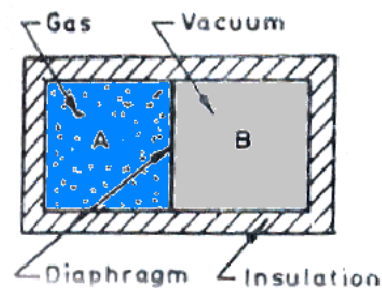

Proof that heat transfer through a finite temperature difference is irreversible

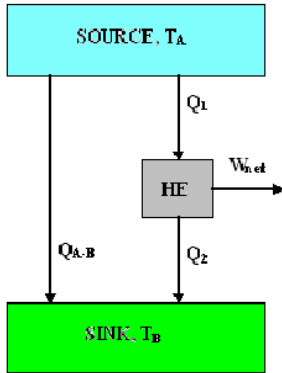

Heat transfer through a finite temperature difference

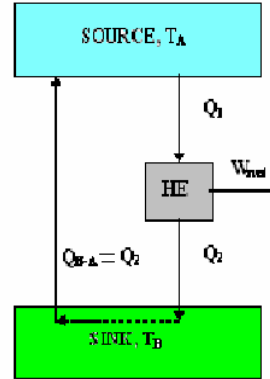

Heat transfer through a finite temperature difference is irreversible

Proof that Unrestrained expansion makes process irreversible

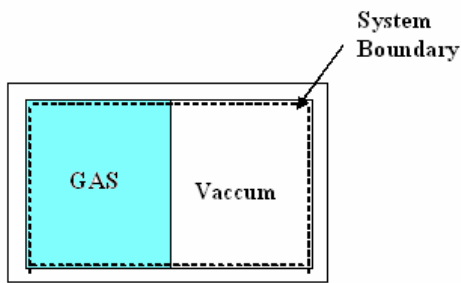

INITIAL STATE

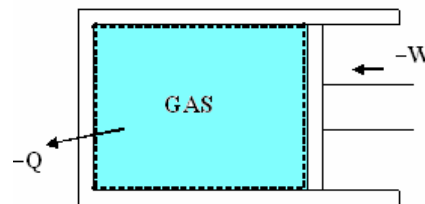

REVERSED PROCESS

CARNOT cycle:

To convert heat continuously into work, at least two thermal reservoirs are required, one will be a HTR (Heat source) which will supply heat to the heat engine and the other will be a low temperature reservoir LTR (sink) to which the heat rejected by the heat engine will flow.

Carnot was the first man to introduce the concept of reversible cycle. The CARNOT engine works between HTR & LTR.

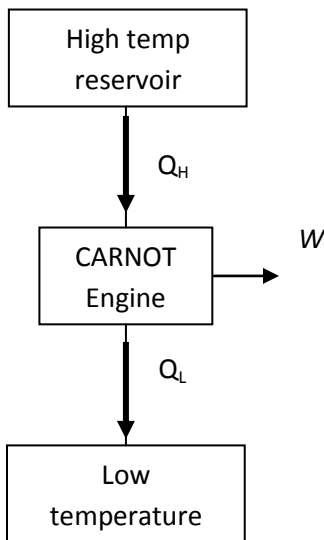

The Carnot cycle consists of an alternate series of two reversible isothermal and two reversible adiabatic processes. Since the processes in the cycle are all reversible the Carnot cycle as a whole is reversible.

The Carnot cycle is independent of the nature of the working substance and it can work with any substance like gas, vapour, electric cell etc.,

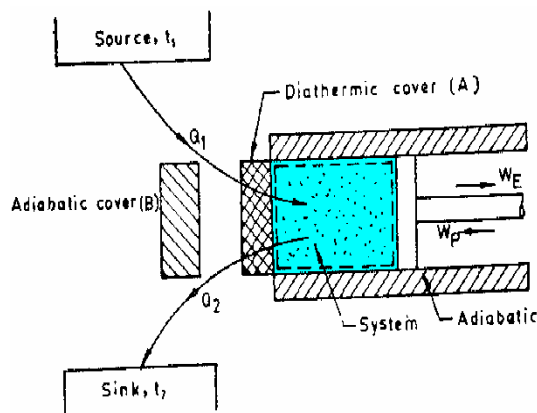

CARNOT CYCLE ENGINE

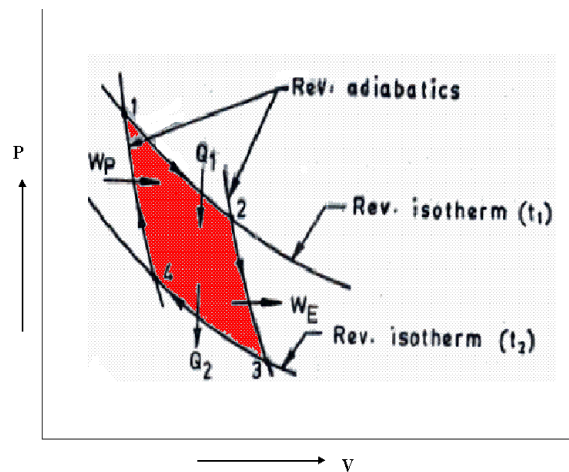

CARNOT CYCLE

- 1) Process 1–2: Gas expands isothermally absorbing heat Q_1 from the source at Temperature T_1 . Work done during this process is given by the area under 1 – 2 (W_{12})
- 2) Process 2–3: During this process cylinder is thermally isolated from the heat reservoir and the head is insulated by the piece of perfect insulator. Gas expands reversibly and adiabatically to temperature T_2 to point 3. Work done is W_{23} .
- 3) Process 3–4: Cylinder is in contact with the heat reservoir at T_2 . Gas is isothermally and reversibly compressed to point 4 rejecting an amount of heat Q_2 to the sink. The work done on the W_{34} .
- 4) Process 4–1: Cylinder is again isolated thermally from the thermal reservoir; gas is recompressed adiabatically and reversibly to point 1. The cycle is now complete. Work done is W_{41}

The efficiency of the Carnot engine is given by,

$$\eta_{\text{carnot}} = \frac{\text{Work output}}{\text{Heat input}} = \frac{Q_1 - Q_2}{Q_1} \text{----- (1)}$$

$$Q_1 = \text{Heat added during process 1 – 2} = mRT_1 \ln \frac{V_2}{V_1} \text{----- (2)}$$

$$Q_2 = \text{Heat rejected during process 3 – 4} = mRT_2 \ln \frac{V_3}{V_4} \text{----- (3)}$$

$$\text{Therefore, } \eta_{\text{carnot}} = \frac{Q_1 - Q_2}{Q_1} = \frac{mRT_1 \ln \frac{V_2}{V_1} - mRT_2 \ln \frac{V_3}{V_4}}{mRT_1 \ln \frac{V_2}{V_1}} = \frac{T_1 \ln \frac{V_2}{V_1} - T_2 \ln \frac{V_3}{V_4}}{T_1 \ln \frac{V_2}{V_1}} \text{----- (4)}$$

Since process 2 – 3 is reversible adiabatic

$$\frac{V_2}{V_3} = \left(\frac{T_2}{T_1} \right)^{\frac{1}{\gamma-1}} \text{----- (5)}$$

Process 4 – 1 is also reversible adiabatic

$$\frac{V_1}{V_4} = \left(\frac{T_2}{T_1} \right)^{\frac{1}{\gamma-1}}, \text{ Therefore, } \frac{V_2}{V_3} = \frac{V_1}{V_4} \text{ or } \frac{V_2}{V_1} = \frac{V_3}{V_4} \text{----- (6)}$$

$$\eta_{\text{carnot}} = \frac{T_1 - T_2}{T_1} \text{-----} (7)$$

$$\eta_{\text{carnot}} = \frac{T_1 - T_2}{T_1} = 1 - \frac{T_2}{T_1} = 1 - \frac{\text{Low Temperature}}{\text{High Temperature}} \text{-----} (8)$$

From the above equation we can have the following conclusions.

Even in an ideal cycle, it is impossible to convert all the energy received as heat from the source into mechanical work. We have to reject some of the energy as heat to a receiver at a lower temperature than the source (sink).

The part of the heat which is converted into work is the available energy. The remainder of the heat which is to be rejected to the sink is unavailable energy.

Carnot cycle is the most efficient cycle, but it is impossible to carry out the Carnot cycle in real engines because of the following reasons.

- i) To achieve isothermal process, the piston must move very slowly allowing heat interchange to keep temperature constant.

- ii) To achieve adiabatic process the piston must move very fast so that the heat interchange is negligible due to very short time available.

The isothermal & adiabatic processes take place in the same stroke which means that for part of the stroke the piston must move very slowly and for remaining part, it must move very fast. But this is not possible.

Since Carnot cycle consists of reversible processes, it may be performed in either direction.

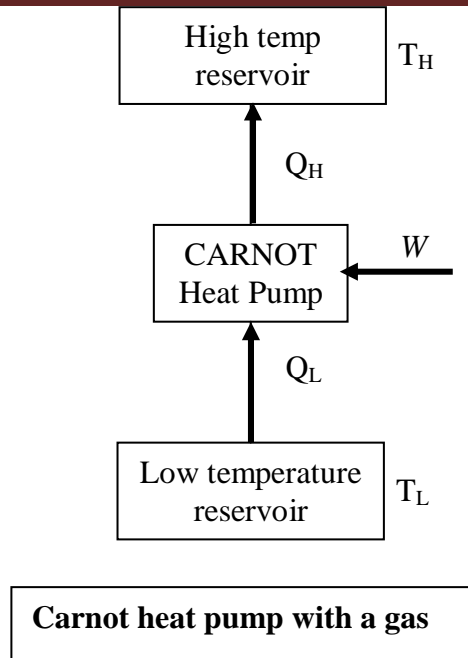

Process 1 - 4	Reversible adiabatic expansion	Temperature falls down from T_H to T_L
Process 4 - 3	Reversible isothermal expansion	Temperature remains constant
Process 3 - 2	Reversible adiabatic Compression	Temperature increases from T_L to T_H
Process 2 - 1	Reversible isothermal Compression	Temperature remains constant

$$\text{COP}_{\text{of heat pump}} = \frac{Q_H}{W} = \frac{Q_H}{Q_H - Q_L} = \frac{T_H}{T_H - T_L}$$

$$\text{COP}_{\text{of refrigerator}} = \frac{Q_L}{W} = \frac{Q_L}{Q_H - Q_L} = \frac{T_L}{T_H - T_L}$$

Problems:

A heat engine works on the Carnot cycle between temperature 900° C & 200° C. If the engine receives heat at the higher temperature at the rate of 60 kW, calculate the power of the engine.

$$T_H = 900 + 273 = 1173 \text{ k}$$

$$T_L = 200 + 273 = 473 \text{ k}$$

$$\eta_{th} = \frac{T_H - T_L}{T_H} = \frac{1173 - 473}{1173} = 0.597$$

Also,
$$\eta_{th} = \frac{\dot{W}}{Q_H} = \frac{\dot{W}}{\dot{Q}_H} \Rightarrow \dot{W} = \eta_{th} Q_H$$

$$\therefore \dot{W} = 0.597 \times 60 = 35.82 \text{ kW}$$

CARNOT theorem and corollary

“An irreversible heat engine cannot have efficiency greater than a reversible one operating between the given two temperatures”.

That is $\eta_{reversible}$ engine is maximum

This theorem can be proved by a process of reasoning.

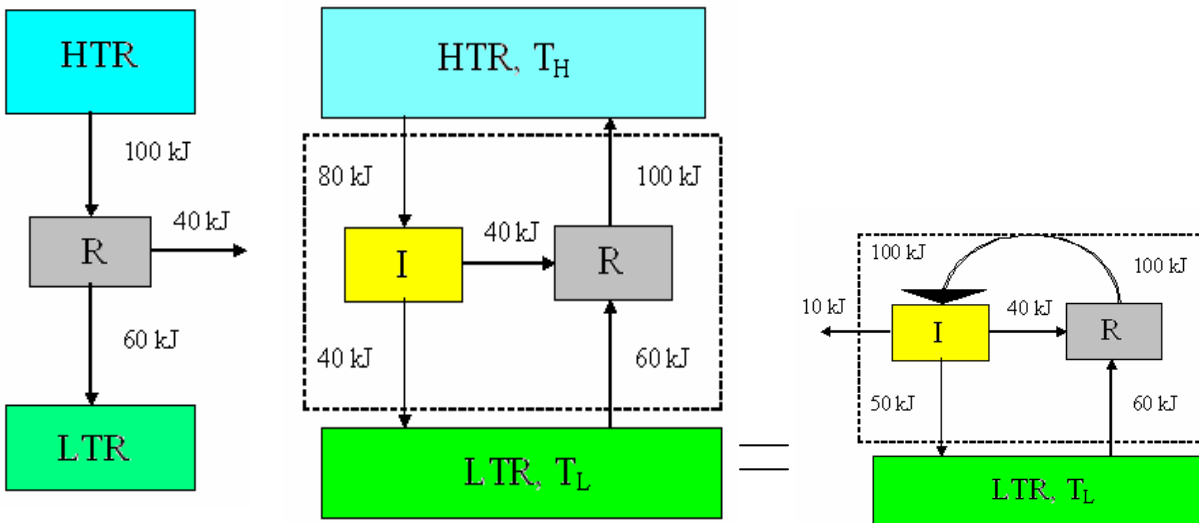

Fig. (a)

Fig. (b)

Fig. (c)

Imagine a reversible engine R as shown in fig (a). The thermal efficiency of the engine is therefore $\frac{40}{100} = 40\%$. Now if this engine is reversed 40 KJ of heat will be necessary to drive it, 60 KJ will be taken from LTR and 100 KJ will be discharged to the HTR.

In fig (b) an irreversible engine I is driving the reversible engine R.

Now for a moment, let us assume that the irreversible engine I is more efficient than the reversible engine R, say $\eta_I = 50\%$. Then, since it takes 40 KJ to drive R, engine I will need to take $Q_H = \frac{W}{\eta_I} = \frac{40}{0.5} = 80\text{KJ}$ from HTR and it will reject 40 KJ to the LTR.

We now observe that, we have in fig (b) an isolated system where in the reversible engine R discharges $100 - 80 = 20$ KJ more to the HTR than the irreversible engine I takes from the HTR. Moreover, the reversible engine R takes $60 - 40 = 20$ KJ more from the cold reservoir than the irreversible engine I rejects to the LTR.

In other words, for the assumed condition that I is more efficient than R, we find that heat is being moved continuously from LTR to HTR without the external aid.

Instead of simply moving the heat as shown in fig (b), we could direct the flow of energy from the reversible engine directly into the irreversible engine, as in fig (c), whose efficiency is 50% would allow to drive engine R, and at the same time deliver 10 KJ of work to something outside of the system. This means the system exchanges heat with a single reservoir and delivers work.

These events have never been known to happen.

\therefore We say that the assumption that I is more efficient than R is impossible.

$$\therefore \eta_I \leq \eta_R$$

Corollary

$$\eta_{\text{rev, engine}} = f(T_H, T_L)$$

All reversible engines have the same efficiency when working between the same two temperatures.

Consider two reversible engines R_1 and R_2 , operating between the two temperatures. If we imagine R_1 driving R_2 backward, then Carnot theorem states that.

$$\eta_{R_1} < \eta_{R_2}$$

If R_2 drives R_1 backward, then

$$\eta_{R_2} < \eta_{R_1}$$

It therefore follows that

$$\eta_{R_1} = \eta_{R_2}$$

If this were not so, the more efficient engine could be used to run the less efficient engine in the reverse direction and the net result would be the transfer of heat from a body at low temperature to a high temperature body. This is impossible according to the second law.

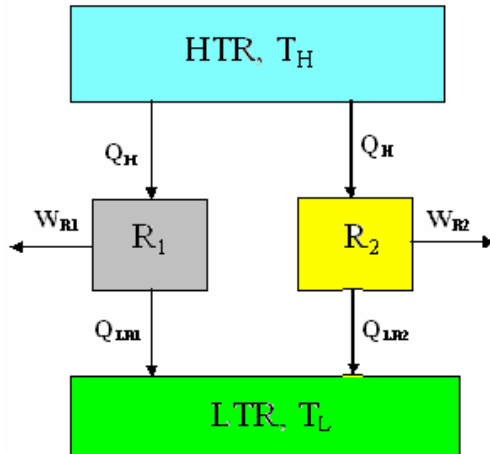

Suppose **R₁** & **R₂** are two reversible engines working between the two same reservoirs as shown let us assume that **R₁** is more efficient than **R₂**.

By our assumption

$$W_{R_1} > W_{R_2}$$

$$\text{i.e., } (Q_H - Q_{LR_1}) > (Q_H - Q_{LR_2})$$

$$\text{i.e., } (Q_{LR_2} > Q_{LR_1})$$

$$\& W_{R_1} - W_{R_2} = (Q_{LR_2} - Q_{LR_1}) \dots\dots\dots (1)$$

Now let engine **R₂** be reversed so that it abstracts heat Q_{LR₂} from LTR at T_L and delivers heat Q_H to HTR at T_H. Since the heat required by **R₁** is also Q_H we can replace the reservoir 1 by a conductor between **R₁** & **R₂**. This new combination would become a PMMK II because it would abstract a net amount of heat (Q_{LR₂} - Q_{LR₁}) from the single reservoir at T_L and convert it completely into work.

$$W_{net} = W_{R_1} - W_{R_2} = Q_{LR_2} - Q_{LR_1}$$

But this is impossible; hence the corollary must be true.

The Thermodynamics Temperature Scale

Zeroth law provides a basis for temperature measurement, but it has some short comings, since the measurement of temperature depends on the thermometric property of a particular substance and on the mode of working of the thermometer.

We know that the η of a reversible engine operating between two thermal reservoirs at different temperatures depends only on the temperatures of the reservoir and is independent of the nature of the working fluid.

With this principle lord Kelvin decided a temperature scale that is independent of the thermometric property of the working substance and this is the Kelvin temperature scale or thermodynamic temperature scale or absolute temperature scale.

The concept of this temperature scale may be developed as follows.

$$\eta_{th} = 1 - \frac{Q_L}{Q_H} = \Phi(T_L, T_H) \dots\dots\dots(1)$$

Where, T \rightarrow absolute temperature

There are many functional relations possible to relate Q_L & Q_H to T_L & T_H , which will serve to define the absolute scale. the relation that has been selected for the thermodynamic scale of temperature is

$$\frac{T_H}{T_L} = \frac{Q_H}{Q_L} \dots\dots\dots(2)$$

The Carnot efficiency may be expressed as

$$\eta_{th} = 1 - \frac{Q_L}{Q_H} = 1 - \frac{T_L}{T_H} \dots\dots\dots(3)$$

This means that if η_{th} of a Carnot cycle operating between two given constant temperature reservoirs is known, the ratio of the to absolute temperature is also known, in order to assign values of absolute temperature, however one other relation between T_L and T_H must be known.

Construction of Kelvin temperature scale

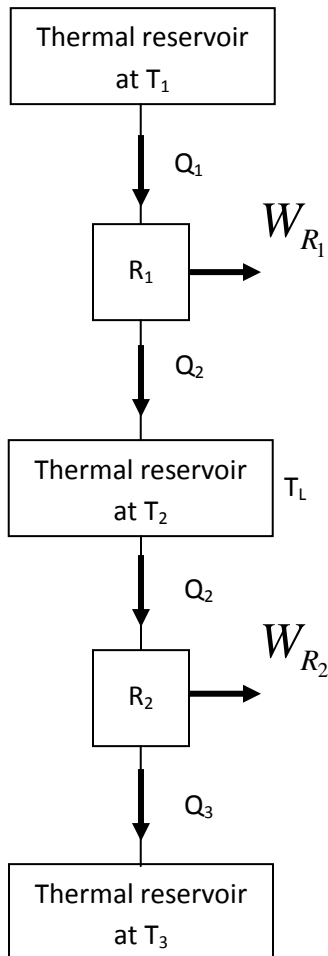

Consider a series of reversible engines operating between thermal temperature reservoirs in the following way. R1 absorbs an amount of heat Q1 from a thermal reservoir at T1 and rejects heat Q2 to a thermal reservoir at T2. R2 absorbs an amount of heat Q2 from the reservoir at T2 and rejects Q3 to a reservoir at T3 and so on. The temperatures are selected in such a way that the work done by each engine is the same i.e.,

$$W_{R_1} = W_{R_2} = W_{R_3} = \dots = W$$

Or

$$(Q_1 - Q_2) = (Q_2 - Q_3) = (Q_3 - Q_4) = \dots = W \longrightarrow (1)$$

From the definition of Kelvin temperature scale we have

$$\frac{Q_1}{Q_2} = \frac{T_1}{T_2}, \frac{Q_2}{Q_3} = \frac{T_2}{T_3}, \frac{Q_3}{Q_4} = \frac{T_3}{T_4} \dots \text{etc}$$

$$\therefore \frac{Q_1}{T_1} = \frac{Q_2}{T_2} = \frac{Q_3}{T_3} = \dots \quad (2)$$

On solving equations (1) & (2) we get

$$T_1 - T_2 = T_2 - T_3 = T_3 - T_4 = \dots \quad (3)$$

From this equations we conclude that the reversible engines operating in series in this way as shown in Fig develops equal work when the temperature difference across them are equal.

Now a decision to be made on the magnitude of the degree of the Kelvin temperature scale. This is usually done by choosing the steam point and the ice point at one atmosphere as the reference temperatures. As the difference between these points is 100 degrees, we can write

$$T_s - T_i = 100 \dots\dots\dots (4)$$



Steam pt



ice pt

On the other equation involving T_s & T_i can be derived experimentally by finding out the η of a reversible engine operating between the steam point and the ice point. The efficiency $\eta = 26.80\%$

Hence, $\eta_R = 1 - \frac{T_i}{T_s} = 0.2680 \quad \therefore \frac{T_i}{T_s} = 0.7320 \dots\dots\dots (5)$

Solving (4) & (5), we get

$$T_s = 373.15 \text{ K}, \quad T_i = 273.15 \text{ K}$$

\therefore Relationship between K & $^{\circ}\text{C}$ is given by K = $^{\circ}\text{C} + 273.15$

Problems (on second Law of thermodynamics)

Problem 1. An engineer claims to have developed an engine which develops 3.4 kW while consuming 0.44 Kg of fuel of calorific value of 41870 kJ / kg in one hour. The maximum and minimum temperatures recorded in the cycle are 1400° C & 350° C respectively is the claim of the engineer genuine (Sept./Oct. 1996)

Solution:

$$\text{Temperature of source, } T_H = 1400^\circ \text{ C} = 1673 \text{ K}$$

$$\text{Temperature of sink, } T_L = 350^\circ \text{ C} = 673 \text{ K}$$

We know that the thermal efficiency of the CARNOT cycle is the maximum between the specified temperature limits and is given as.

$$\eta_{carnot} = 1 - \frac{Q_L}{Q_H} = 1 - \frac{T_L}{T_H}$$

$$\begin{aligned} \text{i.e., } \eta_{carnot} &= 1 - \frac{T_L}{T_H} = 1 - \frac{623}{1673} = 0.628 \\ &= 62.8\% \end{aligned}$$

The thermal efficiency of the engine developed by the engineer is given as

$$\eta_{thermal} = 1 - \frac{\dot{Q}_L}{\dot{Q}_H} = \frac{\dot{W}}{\dot{Q}_H}$$

We have, $\dot{W} = 3.4 \text{ kW}$

$$\dot{Q}_H = \frac{0.44 \times 41870}{3600} = 5.12 \text{ kW}$$

$$\& \eta_{thermal} = \frac{3.4}{5.12} = 0.664 \text{ or } 66.4\%$$

Since $\eta_{thermal} > \eta_{Carnot}$ Engineer claim is not genuine **Answer**

Problem 2. Two Carnot engines A and B are connected in series between two thermal reservoirs maintained at 1000 K and 100 K respectively. Engine A receives 1680 kJ of heat from the high temperature reservoir and rejects heat to Carnot engine B. Engine B takes in the heat rejected by engine A and rejects heat to the low temperature reservoir. If engines A and B have equal thermal efficiencies determine (1) The heat rejected by engine B (2) The temperature at which heat is rejected by engine A and (3) The work done during the process by engines A and B respectively.

Solution:

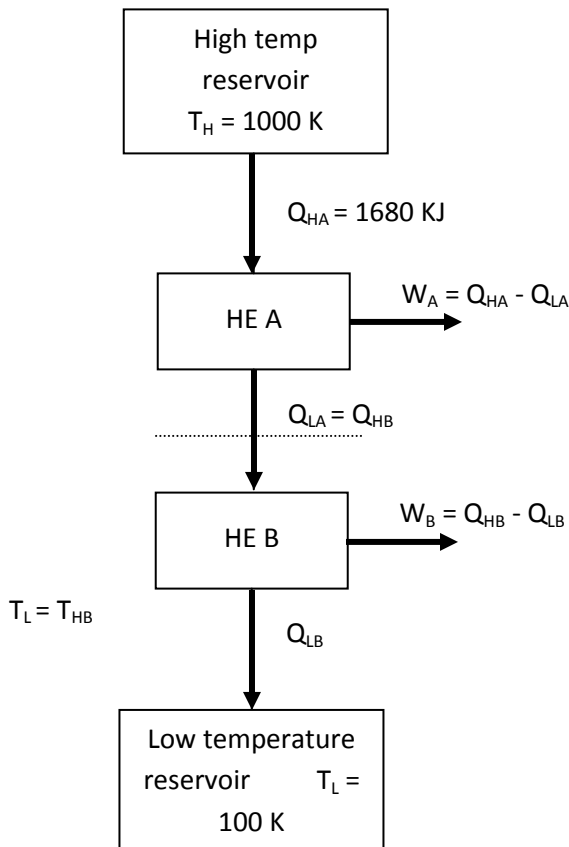

$$Q_{HA} = 1680 \text{ KJ}$$

$$\eta_A = \eta_B$$

We have,

$$\begin{aligned} \eta_A &= 1 - \frac{Q_{LA}}{Q_{HA}} \\ &= 1 - \frac{T_{LA}}{T_H} \end{aligned}$$

$$\& \eta_B = 1 - \frac{Q_{LB}}{Q_{HB}}$$

$$= 1 - \frac{T_L}{T_{HB}}$$

i) Given $\eta_A = \eta_B$

$$\therefore 1 - \frac{T_{LA}}{T_H} = 1 - \frac{T_L}{T_{HB}}$$

$$i.e., \frac{T_L}{T_{HB}} = \frac{T_{LA}}{T_H} \Rightarrow \frac{T_L}{T_{LA}} = \frac{T_{LA}}{T_H} \quad [\because T_{HB} = T_{LA}]$$

$$\begin{aligned} \text{i.e., } T_{LA}^2 &= T_L \times T_H = 100 \times 1000 \\ &= 100000 \text{ K}^2 \end{aligned}$$

[∴ $T_{LA} = T_{HB} = 316.23 \text{ K}$, i.e., the temperature at which heat is rejected by engine A]

ii) We have also

$$\begin{aligned} \eta_A = \eta_B &= 1 - \frac{T_{LA}}{T_H} = 1 - \frac{316.23}{1000} \\ &= 0.684 \text{ or } 68.4\% \end{aligned}$$

The heat rejected by engine B

$$\eta_B = 1 - \frac{Q_{LA}}{Q_{HB}} = 1 - \frac{T_{LH}}{T_{HB}} = 1 - \frac{T_L}{T_{LA}}$$

$$\text{i.e., } \frac{Q_{LB}}{Q_{HB}} = \frac{T_L}{T_{LA}} \Rightarrow Q_{LB} = Q_{HB} \frac{T_L}{T_{LA}} \text{-----(1)}$$

We have,

$$\eta_A = 1 - \frac{Q_{LA}}{Q_{HA}} = 1 - \frac{T_{LA}}{T_H}$$

$$\begin{aligned} \text{i.e., } Q_{LA} &= Q_{HA} \frac{T_{LA}}{T_H} = 1680 \times \frac{316.23}{1000} \\ &= 531.27 \text{ KJ} = Q_{HB} \end{aligned}$$

Substituting this in (1) we get $Q_{LB} = 531.27 \times \frac{100}{316.23} = 168 \text{ KJ}$ Ans.

iii) Work done

$$W_A = Q_{HA} - Q_{LA} = 1680 - 531.27 = 1148.73 \text{ KJ}$$

$$W_B = Q_{HB} - Q_{LB} = 531.27 - 168 = 363.27 \text{ KJ}$$

Problem 3. A reversible refrigerator operates between 35°C and -12°C . If the heat rejected to reservoir is 1.3 kW , determine the rate at which to heat is leaking into the refrigerator.

Solutions: Reversible refrigerator

$$T_H = 35^\circ \text{C} = 308 \text{ K}$$

$$T_L = -12^\circ \text{C} = 261 \text{ K}$$

$$(\text{COP})_{\text{Ref}} = \frac{\dot{Q}_L}{\dot{W}} = \frac{\dot{Q}_L}{\dot{Q}_H - \dot{Q}_L}$$

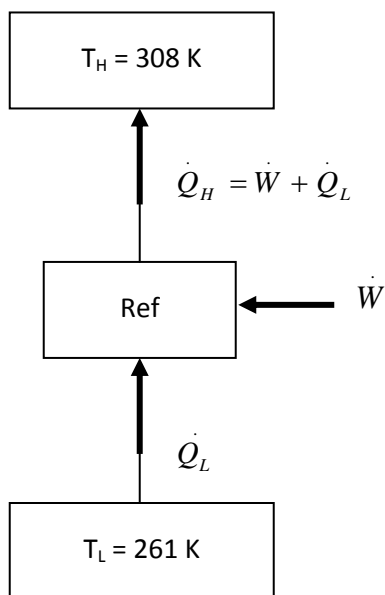

$$= \frac{T_L}{T_H - T_L} \quad (\because \text{It is a reversible refrigerator})$$

$$\begin{aligned} \text{i.e., } \frac{\dot{Q}_L}{\dot{Q}_H - \dot{Q}_L} &= \frac{T_L}{T_H - T_L} = \frac{261}{308 - 261} \\ &= 5.553 \end{aligned}$$

$$\text{i.e., } \dot{Q}_L = 5.553 \left[\dot{Q}_H - \dot{Q}_L \right] = 5.553 \dot{Q}_H - 5.553 \dot{Q}_L$$

$$\text{i.e., } \dot{Q}_L + 5.553 \dot{Q}_L = 5.553 \dot{Q}_H$$

$$\text{i.e., } \dot{Q}_L = \frac{5.553}{6.553} \times \dot{Q}_H = \frac{5.553}{6.553} \times 1.3 = 1.102 \text{ kW Ans.}$$

Problem 4. A reversible power cycle is used to drive heat pump cycle. The power cycle takes in Q_1 heat units at T_1 K and rejects Q_2 at T_2 K. The heat pump abstract Q_4 from the sink at T_4 k and discharges Q_3 units of heat to a reservoir at T_3 K. Develop an expression for the ratio Q_4 / Q_1 in terms of the four temperatures

Solution:-

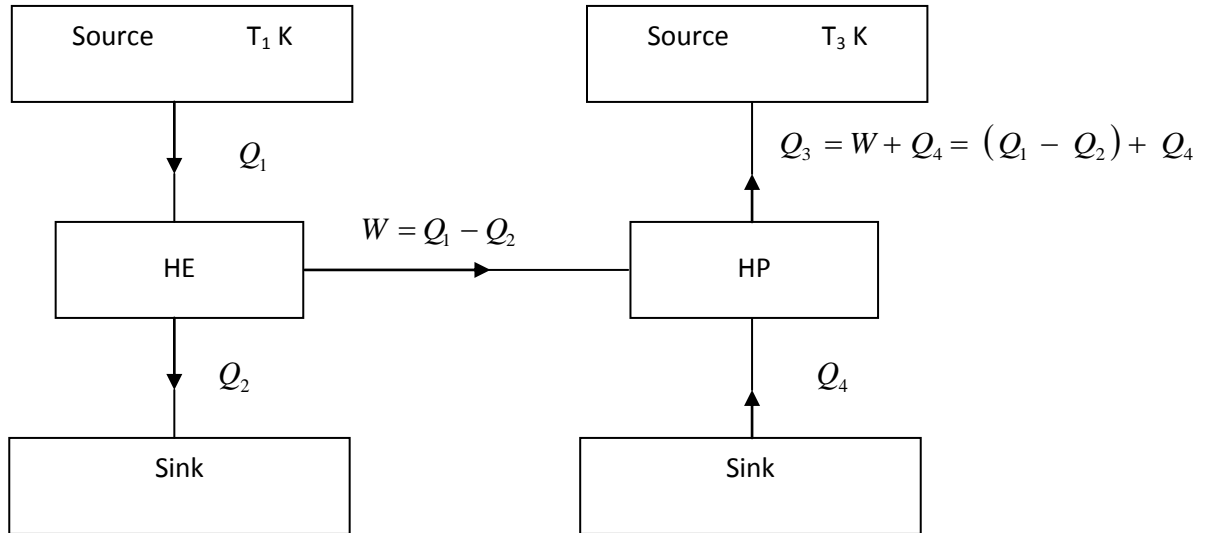

We have

For reversible power cycle,

$$\eta_{thermal} = \frac{Q_1 - Q_2}{Q_1} = \frac{T_1 - T_2}{T_1} \text{-----(1)}$$

For reversible heat pump cycle,

$$(COP)_{H.P} \frac{Q_3}{Q_3 - Q_4} = \frac{T_3}{T_3 - T_4} \text{-----(2)}$$

Multiply (1) by (2), we get

$$\frac{(Q_1 - Q_2)}{Q_1} \times \frac{Q_3}{Q_3 - Q_4} = \frac{(T_1 - T_2)}{T_1} \times \frac{T_3}{(T_3 - T_4)}$$

Considering LHS,

Since $Q_3 - Q_4 = W = Q_1 - Q_2$, we get

$$\frac{Q_1 - Q_2}{Q_1} \times \frac{Q_3}{Q_1 - Q_2} = \frac{Q_3}{Q_1} = \frac{W + Q_4}{Q_1}$$

$$= \frac{(Q_1 - Q_2) + Q_4}{Q_1} = \frac{(Q_1 - Q_2)}{Q_1} + \frac{Q_4}{Q_1}$$

$$= \left(\frac{T_1 - T_2}{T_1} \right) + \frac{Q_4}{Q_1}$$

On substitution in the above equation

$$\left(\frac{T_1 - T_2}{T_1} \right) + \frac{Q_4}{Q_1} = \left(\frac{T_1 - T_2}{T_1} \right) \times \frac{T_3}{(T_3 - T_4)}$$

$$\text{i.e., } \frac{Q_4}{Q_1} = \left(\frac{T_1 - T_2}{T_1} \right) \times \left(\frac{T_3}{(T_3 - T_4)} \right) - \left(\frac{T_1 - T_2}{T_1} \right)$$

$$= \left(\frac{T_1 - T_2}{T_1} \right) \left(\frac{T_3}{(T_3 - T_4)} - 1 \right)$$

$$= \left(\frac{T_1 - T_2}{T_1} \right) \left(\frac{T_3 - T_3 + T_4}{T_3 - T_4} \right)$$

$$= \left(\frac{T_1 - T_2}{T_1} \right) \times \left(\frac{T_4}{T_3 - T_4} \right) \text{ Ans}$$

Problem 5. A Heat engine is used to drive a heat pump. The heat transfers from the heat engine and from the heat pump are used to heat the water circulating through the radiators of a building. The efficiency of the heat engine is 27% and the coefficient performance of heat pump is 4. Evaluate the ratio of heat transfer to the circulating water to the heat transfer to the heat engine.

Solution:-

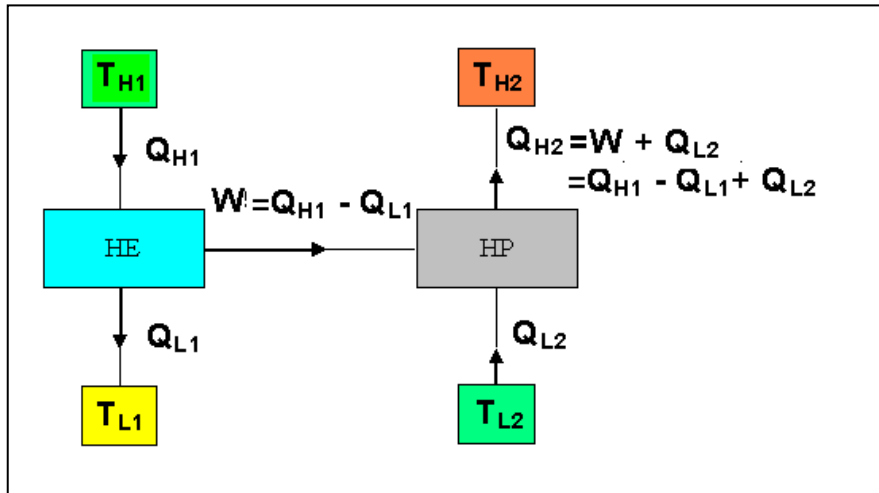

$$\eta_{HE} = 27\%$$

$$(\text{COP})_{HP} = 4$$

We have

$$\text{Heat rejected from heat engine} = Q_{L_1}$$

$$\text{Heat transfer from heat pump} = Q_{H_2}$$

$$\text{Heat transfer from circulating water} = Q_{L_1} + Q_{H_2}$$

∴ The ratio of heat transfer to the circulating water to the heat transfer to the engine

$$= \frac{Q_{L_1} + Q_{H_2}}{Q_{H_1}} \text{-----(1)}$$

We also have,

$$\eta_{HE} = \frac{Q_{H_1} - Q_{L_1}}{Q_{H_1}} = 0.27 \text{-----(2)}$$

$$(COP)_{HP} = \frac{Q_{H_2}}{Q_{H_2} - Q_{L_2}} = 4 \text{-----(3)}$$

We have from (2),

$$Q_{L_1} = Q_{H_1} - 0.27 Q_{H_1} = 0.73 Q_{H_1} \text{-----(4)}$$

From (3),

$$\begin{aligned} Q_{H_2} &= 4 \times (Q_{H_2} - Q_{L_2}) = 4 \times (Q_{H_1} - Q_{L_1}) \\ &= 4 \times (Q_{H_1} - 0.73 Q_{H_1}) = 1.08 Q_{H_1} \text{-----(5)} \end{aligned}$$

Substituting in equation (1), We obtain

$$\frac{(Q_{L_1} + Q_{H_2})}{Q_{H_1}} = \frac{0.73 Q_{H_1} + 1.08 Q_{H_1}}{Q_{H_1}} = 1.81 \text{ Ans.}$$

Problem 6. It is proposed to construct a refrigeration plant for a cold storage to be maintained at -3°C . The ambient temperature is 27°C . If 5×10^6 kJ /hr of energy has to be continuously removed from the cold storage, calculate the maximum power required to run.

Problem 7. There are three reservoirs at temperatures of 827°C , 127°C and 27°C parallel. A reversible heat engine operates between 827°C and 127°C and a reversible refrigerator operates between 27°C and 127°C respectively 502 kJ of heat are extracted from the reservoir at 827°C by the heat engine and 251 kJ of heat are abstracted by the refrigerator from the reservoir at 27°C . Find the net amount of heat delivered to the reservoir at 127°C .

Can the heat engine drive the refrigerator and still deliver some net amount of work? If so how much?

Solutions: Given: Reversible heat engine and refrigerator

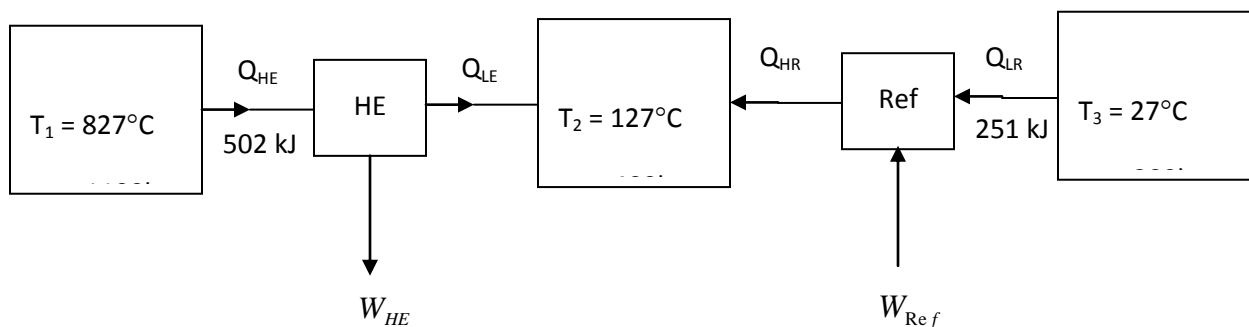

$$\text{For heat engine } \eta = 1 - \frac{Q_{LE}}{Q_{HE}} = 1 - \frac{T_2}{T_1}$$

$$\text{For Refrigerator } (COP)_{Ref} = 1 - \frac{Q_{LR}}{Q_{HR} - Q_{LR}} = \frac{T_3}{T_2 - T_3}$$

$$\text{We have } \eta = 1 - \frac{400}{1100} = 0.636$$

$$\text{Also, } \frac{W_{HE}}{Q_{HE}} = 0.636 \Rightarrow W_{HE} = 0.636 \times 502 = 319.27 \text{ kJ}$$

$$\& (COP)_{Ref} = \frac{T_3}{T_2 - T_3} = \frac{300}{400 - 300} = 3.0$$

$$\text{Also } \frac{Q_{LR}}{Q_{HR} - Q_{LR}} = 3.0 \Rightarrow Q_{LR} = 3.0 (Q_{HR} - Q_{LR})$$

$$Q_{LR} = 3Q_{HR} - 3Q_{LR} \Rightarrow 3Q_{HR} = 4Q_{LR}$$

$$\text{i.e., } Q_{HR} \frac{4}{3} Q_{HR} = \frac{4}{3} \times 251 = 334.67 \text{ kJ}$$

$$\text{For HE, } Q_{LE} = Q_{HE} - W_{HE} = 502 - 319.27 = 182.73 \text{ kJ}$$

Net amount of Heat delivered

$$Q_{LE} + Q_{HR} = 182.73 + 334.67 = 517.4 \text{ kJ Ans.}$$

W_{Ref} i.e. work required to drive the refrigerator

$$= Q_{HR} - Q_{LR} = 334.67 - 251 = 83.67 \text{ kJ}$$

Since $W_{HE} > W_{Ref}$ Heat engine drives the refrigerator and still deliver some net amount of work

$$\text{i.e., } W_{HE} - W_{Ref} = 319.27 - 83.67 = 235.6 \text{ kJ}$$

THE THERMODYNAMIC TEMPERATURE SCALE

A Temperature scale that is independent of the properties of the substances that are used to measure temperature is called a Thermodynamic scale of temperature. It can be defined with the help of reversible heat engines.

The thermal efficiency of a reversible engine is given by

$$\eta_{th, rev} = 1 - \frac{Q_L}{Q_H} = 1 - \frac{T_L}{T_H}$$

i.e., $\eta_{th, rev} = f(T_H, T_L)$ ------(1)

Also, $\frac{Q_L}{Q_H} = f(T_H, T_L)$ ------(2)

If some functional relationship is assigned between T_H , T_L and Q_H , Q_L equation (2) then becomes the definition of a temperature scale.

This functional form of $f(T_H, T_L)$ can be developed by considering the three reversible heat engines as shown.

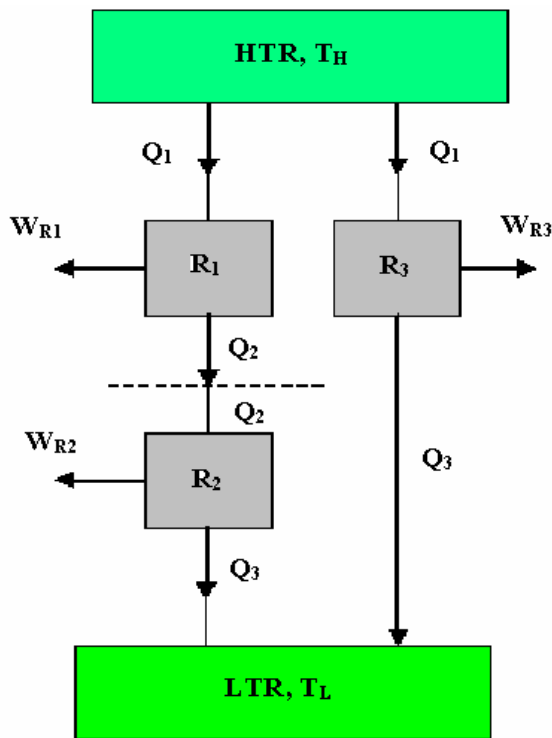

Engines R_1 & R_2 can be combined into one reversible engine operating between the same reservoirs as engine R_3 and thus this combined engine will have the same efficiency as engine R_3

Using equation (2) we can write for engines R_1 , R_2 and R_3 respectively.

$$\frac{Q_1}{Q_2} = f(T_1, T_2), \frac{Q_2}{Q_3} = f(T_2, T_3)$$

and $\frac{Q_1}{Q_3} = f(T_1, T_3)$

Also $\frac{Q_1}{Q_3}$ can be expressed as

$$\frac{Q_1}{Q_3} = \frac{Q_1}{Q_2} \times \frac{Q_2}{Q_3}$$

i.e., $f(T_1, T_3) = f(T_1, T_2) \times f(T_2, T_3)$

From the above equation we see that, the left hand side is a function of T_1 and T_3 , the right hand side too must be a function of T_1 and T_3 , only and not T_2 . That is the value of the product on R.H.S is independent of T_2 . To satisfy this condition, the function f must have the following form:

$$f(T_1, T_2) = \frac{\phi(T_1)}{\phi(T_2)} \quad \& \quad f(T_2, T_3) = \frac{\phi(T_2)}{\phi(T_3)}$$

So that,

$$\frac{Q_1}{Q_3} = f(T_1, T_3) = \frac{\phi(T_1)}{\phi(T_3)} \quad \text{----- (3)}$$

For a reversible heat engine operating between two reservoirs at T_H & T_L , equation (3) can be written as:

$$\frac{Q_H}{Q_L} = \frac{\phi(T_H)}{\phi(T_L)} \quad \text{----- (4)}$$

This is the only condition that the second law stipulates on the ratio of heat flows to and from the reversible heat engines. Since the function $\phi(T)$ is completely arbitrary, several values of it will satisfy equation (4). Lord Kelvin first proposed taking $\phi(T) = T$ to define thermodynamic temperature scale as:

$$\left[\frac{Q_H}{Q_L} \right]_{rev} = \frac{T_H}{T_L} \quad \text{----- (5)}$$

This scale is called the Kelvin scale and the temperatures on this scale are called absolute temperatures.

With equation (5) the thermodynamic scale is not completely defined, since it gives only a ratio of the absolute temperatures. The triple point of water is assigned the value 273.15 k. The magnitude of a Kelvin is defined as 1/273.15 of the temperature interval between absolute zero and triple point temperature of water. The magnitudes of temperature units on the Kelvin and Celsius scales are identical ($1k = 1^\circ C$) the temperature on the scales are related by a constant 273.15 (the temperature of the ice point) as:

$$T (^{\circ}C) = T (k) - 273.15 *$$

Additional Problems:

Problem 8. There are two ways of increasing the efficiency of a Carnot heat engine:

- i) Lowering the temperature T_2 of the low temperature reservoir by ΔT , while keeping the temperature T_1 of the high temperature reservoir a constant.

ii) Increasing the temperature T_1 by ΔT , while keeping the temperature T_2 a constant. Which is more effective? Prove your answer.

Problem 9. An inventor claims that his engine has the following:

Specifications

Heating value of the fuel: 74500 kJ / kg, Temperature limits: 750 °C and 25 °C

Power developed: 75 kW,

Fuel burned: 0.07 kg / min

State whether the claim is valid or not.

Problem 11. A Carnot refrigerator consumes 200 W of power in summer when the ambient atmosphere is 40 °C. The rate of energy leak into the refrigerator is estimated at 20 W per degree Celsius temperature difference between the ambient atmosphere and the cold space of the refrigerator. If the refrigerator is continuously operated, determine the temperature at which the cold space is maintained.

Problem 12. Direct heat engine operating between two reservoirs at 327 °C and 27 °C drives a refrigerator operating between 27 °C and 13 °C. The efficiency of the heat engine and the COP of the refrigerator are each 70% of their maximum values. The heat transferred to the direct heat engine is 500 kJ. The net heat rejected by the engine and the refrigerator to the reservoir at 27 °C is 400 kJ. Find the net work output of the engine-refrigerator combination. Draw the schematic representation.

Problem 13. A reversible heat engine operates between two reservoirs at constant temperature of 160 °C and 20 °C. The work output from the engine is 15 kJ / sec. Determine: i) Efficiency of the cycle ii) Heat transfer from the reservoir at 160 °C iii) heat rejected to the reservoir at 20 °C. If the engine is reversed and operates as a heat pump between the same two reservoirs, determine the COP of the heat pump & the power required when the heat transfer from the reservoir at 20 °C is 300 kJ / min.

Problem 14. A cyclic heat engine operates between a source temperature of 800 °C and a sink temperature of 30 °C. What is the least rate of heat rejection per kW net output of the engine?

Problem 15. A reversible heat engine operates with two environments. In the first it draws 12000 kW from a source at 400 °C and in the second it draws 25000 kW from a source at 100 °C. In both the operations the engine rejects heat to a thermal sink at 20 °C. Determine the operation in which the heat engine delivers more power.

ENTROPY

The first law of thermodynamics introduces the concept of the internal energy U , and this term helps us to understand the nature of energy, as defined by the first law. In the similar way the second law introduces the concept of entropy S , like internal energy it is also a thermodynamic property and is defined only in terms of mathematical operations.

General Discussion:

For a system undergoing a quasistatic process, work done at the boundary is given by,

$$\delta W = P dV \text{ --- (1)}$$

Since a reversible process is a quasistatic process this relation gives the work done at the boundary of a system during a reversible process.

Considering a reversible cycle in which only work involved is done at the boundary of the system, we have

$$\oint \delta Q = \oint \delta W = \oint P dV \text{ --- (2)}$$

Form the equation (2), Work is given by the cyclic integral of product of two properties viz. P is an intensive property & dV is change in an extensive property.

For a reversible cycle when work (which is a path function) is defined by the product of two properties one is intensive and the other is change in an extensive property, why can't Heat (which is also a path function) is defined by the cyclic integral of product of two properties one intensive and the other change in an extensive property.

Yes, the intensive property most closely associated with heat is temperature and the other extensive property for this answer is ENTROPY. Total entropy is denoted by capital letter S and lower case 's' represents the specific entropy, i.e. entropy / unit mass.

If entropy is an extensive property then what exactly is entropy?

Entropy is –

1. The amount of Energy that is not available for work during a certain process
2. A measure of the disorder of a system.
3. Measure of disorganization or degradation in the universe that reduces available energy, or tendency of available energy to dwindle. Chaos, opposite of order.
4. The state of disorder in a thermodynamic system: the more energy the higher the entropy.
5. A measure of the dispersal or degradation of energy.
6. A measure of the disorder or randomness in a closed system. For example, the entropy of an unburned piece of wood and its surroundings is lower than the entropy of the ashes, burnt remains, and warmed surroundings due to burning that piece of wood.
7. The scientific measure of the disorder in a system; the greater the disorder, the greater the entropy.
8. The thermodynamic entropy S , often simply called the entropy in the context of thermodynamics, is a measure of the amount of energy in a physical system that cannot be used to do work. It is also a measure of the disorder present in a system. The SI unit of entropy is $J \cdot K^{-1}$ (joule per Kelvin), which is the same unit as heat capacity.
9. "Entropy" is defined as a measure of unusable energy within a closed or isolated system (the universe for example). As usable energy decreases and unusable energy increases, "entropy" increases. Entropy is also a gauge of randomness or chaos within a closed system. As usable energy is irretrievably lost, disorganization, randomness and chaos increase.

Understanding entropy:

Example 1.

If the particles represent gas molecules at normal temperatures inside a closed container, which of the illustrated configurations came first?

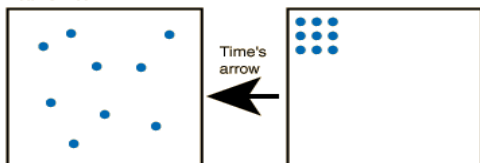

If you tossed bricks off a truck, which kind of pile of bricks would you more likely produce?

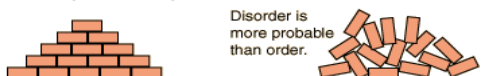

One of the ideas involved in the concept of entropy is that nature tends from order to disorder in isolated systems. This tells us that the right hand box of molecules happened before the left. Using Newton's laws to describe the motion of the molecules would not tell you which came first.

Example 2.

Which is more disordered?
The glass of ice chips or the glass of water?

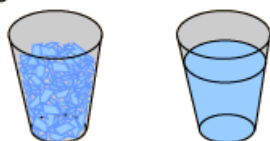

For a glass of water the number of molecules is astronomical. The jumble of ice chips may look more disordered in comparison to the glass of water which looks uniform and homogeneous. But the ice chips place limits on the number of ways the molecules can be arranged. The water molecules in the glass of water can be arranged in many more ways; they have greater "multiplicity" and therefore greater entropy.

Solids have lesser entropy than liquids. Statistically, in solids the atoms or molecules are in their fixed places, whereas in liquids and even more in gases you never know exactly where to find them. The fixed sequence of atoms in solids reflects a higher ordered state.

Consider a body which is heated and another one is cooled. What happens to the entropy of the two bodies? Entropy increases on heating. Does disorder increase, too?

Yes, it does. We know that heat is stored in a piece of matter as the random motion of particles. The hotter a body, the more its atoms and molecules jiggle around. It is not difficult to identify disorder by faster jiggling motion.

CLAUSIUS THEOREM:

The thermal efficiency of reversible Carnot cycle is given by the expression,

$$\eta_{Carnot} = 1 - \frac{Q_L}{Q_H} = 1 - \frac{T_L}{T_H} \text{ or } \frac{Q_H}{T_H} = \frac{Q_L}{T_L} \text{ -----(1)}$$

Where T_H and T_L are the temperatures of high temperature thermal reservoir and low temperature thermal reservoir respectively, and Q_H is the heat supplied and Q_L is the heat rejected by the Carnot engine.

Considering the usual sign convention, +ve for the heat absorbed and -ve for the heat rejected, we may write,

$$\frac{Q_H}{T_H} = -\frac{Q_L}{T_L} \text{ or } \frac{Q_H}{T_H} + \frac{Q_L}{T_L} = 0 \text{ -----(2)}$$

Equation (2) shows that the sum of the quantities $\frac{Q_H}{T_H}$ and $\frac{Q_L}{T_L}$, associated with absorption and rejection of heat by the fluid of a reversible heat engine is zero for the entire cycle. Since the working fluid returns to its initial state at the end of the cycle, it undergoes no net change in properties, suggesting that the quantities $\frac{Q_H}{T_H}$ and $\frac{Q_L}{T_L}$ represents property changes of the working fluid because their sum is zero for the cycle and this is the characteristic of a property or state function. The amount of heat transfer is known to depend on the path of the process. However if the heat is divided by the temperature at which the transfer takes place, the result is independent on the path.

The above conclusion is for the Carnot reversible cycle. But it can be proved that the conclusion is valid for any reversible cycle.

Consider any arbitrary reversible cycle a-b-c-d-a as shown. In such cycle absorption and rejection of heat do not occur at two constant temperatures but take place at continuously changing temperatures.

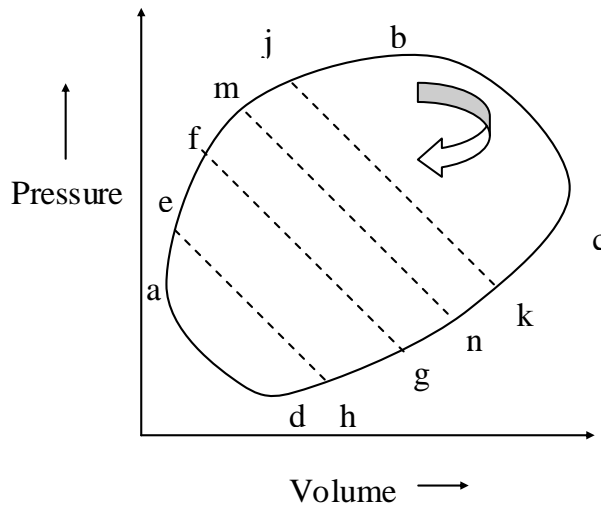

The cycle can be now broken into an infinite number elementary Carnot cycle by drawing a series of infinitely close adiabatic lines, eh, fg, mn, etc. efgh, fmng etc represents elementary Carnot cycle in which sections ef, gh etc can be considered as isothermal lines.

For any differential Carnot cycle, efgh, let Q_{H1} be the heat absorbed during isothermal process ef and Q_{L1} be the heat rejected during the isothermal process gh. The temperature of ef is T_{H1} and gh process is T_{L1} . Then we may write,

$$\frac{Q_{H1}}{T_{H1}} = \frac{Q_{L1}}{T_{L1}}$$

Using proper sign convention +ve for the absorption of heat and -ve for rejection, we get,

$$\frac{Q_{H1}}{T_{H1}} + \frac{Q_{L1}}{T_{L1}} = 0 \text{ ----- (1)}$$

Similarly,

$$\frac{Q_{H2}}{T_{H2}} + \frac{Q_{L2}}{T_{L2}} = 0 \text{ ----- (2) for the cycle fmng}$$

From these relations we see that the algebraic sum of the ratios of the amounts of heat transferred to the absolute temperature for the Carnot cycles taken together is equal to zero, thus,

$$\left(\frac{Q_{H1}}{T_{H1}} + \frac{Q_{L1}}{T_{L1}} \right) + \left(\frac{Q_{H2}}{T_{H2}} + \frac{Q_{L2}}{T_{L2}} \right) + \text{-----} = 0$$

$$\text{i.e. } \sum \left(\frac{Q_H}{T_H} + \frac{Q_L}{T_L} \right) = 0 \text{-----(3)}$$

As the number of Carnot cycles is very large, the sum of the terms $\frac{Q}{T}$ over the complete cycle becomes equal to the cyclic integral of $\frac{\delta Q}{T}$, We may, therefore write

$$\oint_R \frac{\delta Q}{T} = 0 \text{-----(4)}$$

Where R represents reversible cycle. This result is known as **CLAUSIUS THEOREM**. $\frac{\delta Q}{T}$ is known as **ENTROPY**.

ENTROPY:

Definition: Entropy, S is a property of system such that its increase $S_2 - S_1$ as the system changes from state 1 to state 2 is given by,

$$S_2 - S_1 = \int_1^2 \frac{\delta Q_R}{T} \text{-----(1)}$$

In differential form equation (1) can be written as $dS = \frac{\delta Q_R}{T}$

THE CLAUSIUS INEQUALITY:

When any system undergoes a cyclic process, the integral around the cycle of $\frac{\delta Q}{T}$ is less than or equal to zero.

In symbols, $\oint \frac{\delta Q}{T} \leq 0 \text{-----(1)}$

Where δQ is an infinitesimal heat transfer, **T** is absolute temperature of the part of the system to which heat transfer δQ occurs.

PROOF:

For any reversible cycle from Clausius theorem,

$$\oint_R \frac{\delta Q}{T} = 0 \text{-----(2)}$$

From the Carnot's theorem we know that the efficiency of an irreversible engine is less than that of a reversible engine, i.e. $\eta_I < \eta_R$

Where η_I is efficiency of the irreversible engine and η_R is efficiency of the reversible engine.

$$\text{Hence, } 1 - \left(\frac{\delta Q_L}{\delta Q_H} \right)_I < 1 - \left(\frac{\delta Q_L}{\delta Q_H} \right)_R \text{ ----- (3)}$$

Where I and R represents irreversible and reversible processes respectively.

For a reversible engine, the ratio of the heat absorbed and heat rejected is equal to the ratio of the absolute temperatures. Therefore

$$1 - \left(\frac{\delta Q_L}{\delta Q_H} \right)_I < 1 - \left(\frac{T_L}{T_H} \right) \text{ ----- (4)} \quad \text{i.e.} \quad \left(\frac{\delta Q_L}{\delta Q_H} \right)_I > \left(\frac{T_L}{T_H} \right)$$

$$\text{or} \quad \left(\frac{\delta Q_H}{\delta Q_L} \right)_I < \left(\frac{T_H}{T_L} \right) \quad \text{i.e.} \quad \left(\frac{\delta Q_H}{T_H} \right)_I - \left(\frac{\delta Q_L}{T_L} \right)_I < 0 \text{ ----- (5)}$$

Using sign conventions of +ve for absorption of heat and -ve for the rejection of heat, we get,

$$\left(\frac{\delta Q_H}{T_H} \right)_I + \left(\frac{\delta Q_L}{T_L} \right)_I < 0 \text{ ----- (6)}$$

From this we see that the algebraic sum of the ratios of the amounts of heat transferred to the absolute temperature for a cyclic irreversible process is always less than zero,

$$\oint_I \frac{\delta Q}{T} < 0 \text{ ----- (7)}$$

$$\text{Combining equations (2) and (7), we get } \oint \frac{\delta Q}{T} \leq 0 \text{ ----- (8)}$$

This is known as **CLAUSIUS INEQUALITY**.

CLAUSIUS INEQUALITY is helpful in determining whether the process is reversible or not.

If $\oint \frac{\delta Q}{T} = 0$, the cycle is reversible, $\oint \frac{\delta Q}{T} < 0$, the cycle is irreversible and possible and

$\oint \frac{\delta Q}{T} > 0$, the cycle is impossible since it violates the second law of thermodynamics.

ILLUSTRATION OF CLAUSIUS INEQUALITY:

Example 1. Consider the flow of heat from the reservoir at temp T_1 to that at T_2 across the conductor as shown. Conductor is the system. In the steady state there is no change in the state of the system.

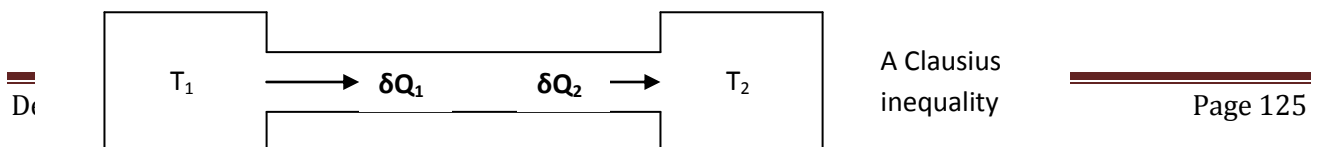

Let $\delta Q_1 = 1000 \text{ kJ}$, $T_1 = 500 \text{ K}$, $T_2 = 250 \text{ K}$

Since $\delta Q_1 = 1000 \text{ kJ}$, $\delta Q_2 = -1000 \text{ kJ}$

$$\sum \frac{\delta Q}{T} = \frac{1000}{500} - \frac{1000}{250} = -2.5 \text{ kJ/K}, \text{ Hence } \sum \frac{\delta Q}{T} < 0, \text{ proved.}$$

Example 2. E is the system which executes a cyclic process.

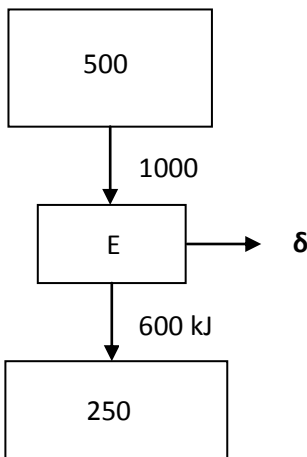

$$\sum \frac{\delta Q}{T} = \frac{1000}{500} - \frac{600}{250} = -0.4 \text{ kJ/K}$$

However, if E were a reversible engine, then work δW would have been,

$$\delta W = \frac{1000(500 - 250)}{500} = 500 \text{ kJ} \quad \text{and}$$

$$\sum \frac{\delta Q}{T} = \frac{1000}{500} - \frac{1000 - 500}{250} = 0 \text{ kJ/K}$$

Hence

A heat engine receives reversibly 420 kJ of heat from a source at 27°C . It rejects heat reversibly to a sink at 27°C . There are no other heat transfers. For each of the three hypothetical

amounts of heat rejected, in (a), (b) and (c) below, compute the cyclic integral of $\frac{\delta Q}{T}$. From these

results show which case is irreversible, which reversible and which impossible. (a) 210 kJ / cycle rejected (b) 105 kJ / cycle rejected and (c) 315 kJ / cycle rejected.

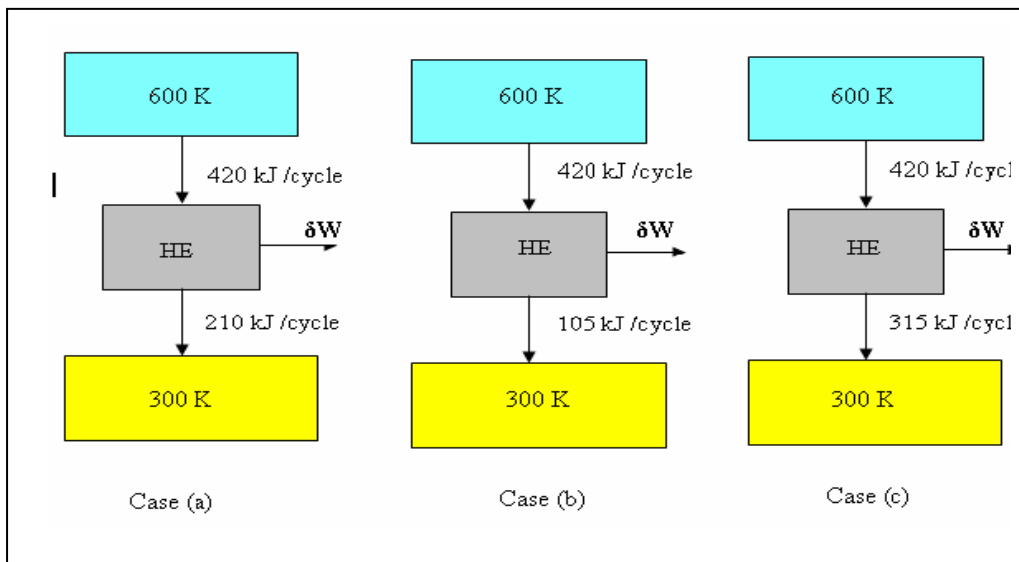

Case (a)

$$\sum \frac{\delta Q}{T} = \frac{420}{600} - \frac{210}{300} = 0, \text{ Since } \sum \frac{\delta Q}{T} = 0, \text{ reversible}$$

Case (b)

$$\sum \frac{\delta Q}{T} = \frac{420}{600} - \frac{105}{300} = 0.35, \text{ Since } \sum \frac{\delta Q}{T} > 0, \text{ Impossible}$$

Case (c)

$$\sum \frac{\delta Q}{T} = \frac{420}{600} - \frac{315}{300} = -0.35, \text{ Since } \sum \frac{\delta Q}{T} < 0, \text{ irreversible}$$

ENTROPY IS A PROPERTY:

Proof that entropy is a property:

Statement: For any system undergoing internally reversible cycle, the integral of $\frac{\delta Q_R}{T}$ is zero, in

symbols, $\oint \frac{\delta Q_R}{T} = 0 \text{ -----(1)}$

Let the system executes a cyclic process, starting at state 1, proceeding to state 2 along the reversible path A, and returning state 1 along a different path B.

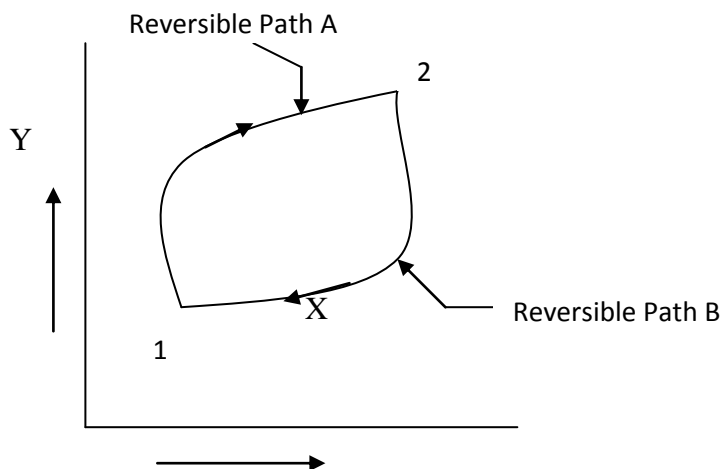

From the Clausius inequality we have along path 1A2B1, $\oint \frac{\delta Q_R}{T} \leq 0 \text{ -----(2)}$

Since the process is reversible, we may reverse it and thus cause the system to retrace its path precisely. Let the element of heat transfer corresponding to the system boundary at temperature T be $\delta Q'_R$, for this reversed process.

Then we have along path 1B2A1,
$$\oint \frac{\delta Q'_R}{T} \leq 0 \text{ -----(3)}$$

But, since the second cycle is simple the first one with the direction reversed, we have,

$$\delta Q'_R = -\delta Q_R \text{ ----- (4)}$$

Therefore, statement (3) becomes; along path 1B2A1,
$$-\oint \frac{\delta Q_R}{T} \leq 0 \text{ -----(5)}$$

or
$$\oint \frac{\delta Q_R}{T} \geq 0 \text{ -----(6)}$$

Comparing statements (2) and (6) we see that they can be both true simultaneously only

if,
$$\oint \frac{\delta Q_R}{T} = 0 \text{ -----(7)}$$
, hence Entropy is a property.

Statement: The integral of $\frac{\delta Q_R}{T}$, when a system executes any reversible process between fixed end states, is independent of the path of the process.

In symbols, for arbitrary paths A and B,
$$\int_{1A}^2 \frac{\delta Q_R}{T} = \int_{1B}^2 \frac{\delta Q_R}{T}$$

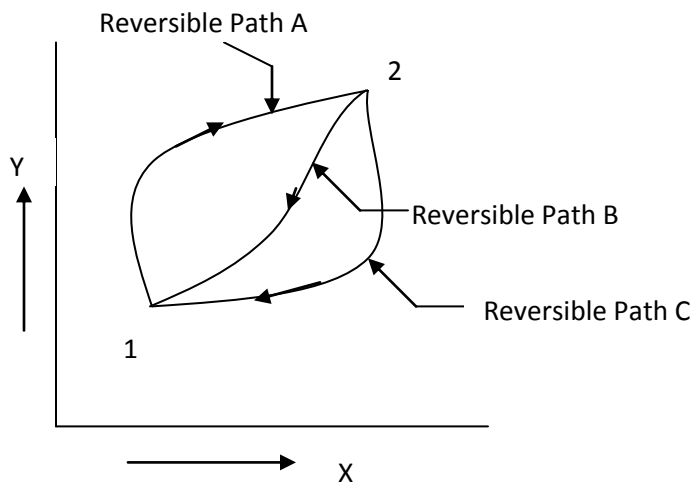

Consider a system which executes a reversible cyclic process, from 1 along path A to 2, and back along path C to 1. Then we have,

$$\oint_{AC} \frac{\delta Q_R}{T} = \int_{1A}^2 \frac{\delta Q_R}{T} + \int_{2C}^1 \frac{\delta Q_R}{T} = 0 \text{ ----- (1)}$$

Similarly, for the reversible cyclic process 1B2C1, we can write,

$$\oint_{BC} \frac{\delta Q_R}{T} = \int_{1B}^2 \frac{\delta Q_R}{T} + \int_{2C}^1 \frac{\delta Q_R}{T} = 0 \text{ ----- (2)}$$

From equations (1) and (2) we get, i.e. (1) – (2) gives,

$$\int_{1A}^2 \frac{\delta Q_R}{T} + \int_{2C}^1 \frac{\delta Q_R}{T} - \int_{1B}^2 \frac{\delta Q_R}{T} - \int_{2C}^1 \frac{\delta Q_R}{T} = 0 \text{ ----- (2)}$$

i.e.
$$\int_{1A}^2 \frac{\delta Q_R}{T} = \int_{1B}^2 \frac{\delta Q_R}{T} \text{ ----- (3)}$$

Path A and path B are arbitrary and $\int_1^2 \frac{\delta Q_R}{T}$ has the same value for any reversible

path between (1) and (2) , hence from the definition of entropy we may write (S₂- S₁) has the same value for any reversible path between 1 and 2 . Therefore **ENTROPY** is a property.

CALCULATION OF ENTROPY CHANGE FOR DIFFERENT PROCESS

Entropy change in **IRREVERSIBLE** process:

For a process that occurs irreversibly, the change in entropy is greater than the heat change divided by the absolute temperature. In symbols,

$$dS > \frac{\delta Q}{T}$$

Proof:

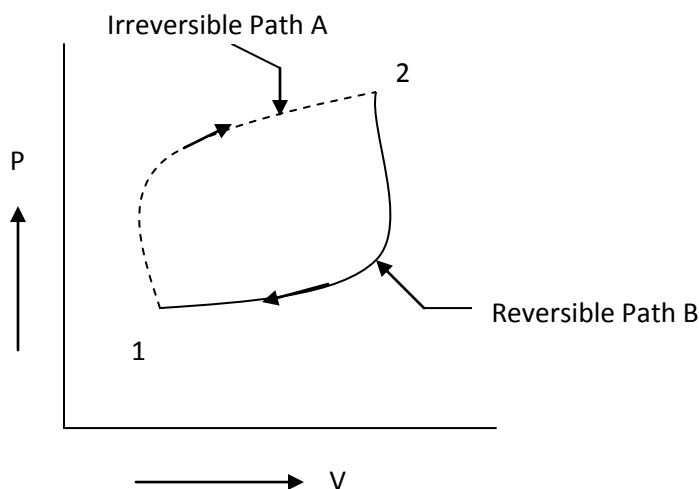

Consider an arbitrary irreversible cycle 1-A-2-B-1 as shown in figure. The path 1 to 2 (1-A-2) is traversed irreversibly and the path 2 to 1 (2-B-1) reversibly. From the Clausius Inequality, we have

$$\oint \frac{\delta Q}{T} < 0, \text{ for the cycle which is irreversible and}$$

$$\oint \frac{\delta Q}{T} = 0, \text{ for the cycle which is reversible} \text{----- (1)}$$

Since the entropy is a thermodynamic property, we can write

$$\oint dS = \int_{1A}^2 dS_I + \int_{2B}^1 dS_R = 0 \text{----- (2)}$$

For a reversible process we have, $\int_{2B}^1 dS_R = \int_{2B}^1 \frac{\delta Q_R}{T}$ ----- (3)

Substituting this in equation (2), we get

$$\int_{1A}^2 dS_I + \int_{2B}^1 \frac{\delta Q_R}{T} = 0 \text{----- (4)}$$

Using equation (1), for an irreversible cycle,

$$\oint \frac{\delta Q}{T} = \int_{1A}^2 \left(\frac{\delta Q}{T} \right)_I + \int_{2B}^1 \left(\frac{\delta Q}{T} \right)_R < 0 \text{----- (5)}$$

Now subtracting equation (5) from equation (4), we get

$$\int_{1A}^2 dS_I > \int_{1A}^2 \left(\frac{\delta Q}{T} \right)_I \text{----- (6)}$$

For small changes in states the above expression can be written as,

$$dS_I > \left(\frac{\delta Q}{T} \right)_I \text{----- (7)}$$

Where the subscript I represents the irreversible process. The equation (7) states that in an irreversible process the change in entropy is greater than $\frac{\delta Q}{T}$. Therefore we can write,

$dS_I \geq \frac{\delta Q}{T}$, where equality sign is for reversible process and inequality sign is for irreversible process.

IMPORTANT: The effect of irreversibility is always to increase the entropy of the system. If an isolated system is considered, from the first law of thermodynamics the internal energy of the system will remain constant. $\delta Q=0$, from the above expression $dS_{isolated} \geq 0$, i.e., the entropy of an isolated system either increases or remains constant. This is a corollary of the second law of thermodynamics and this explains the principle of increase in entropy.

MATHEMATICAL EXPRESSION OF THE SECOND LAW:

$Q = TdS$ for reversible processes and $Q < TdS$ for irreversible processes

The above equation may be regarded as the analytical expression of the second law of thermodynamics.

ENTROPY CHANGES FOR AN OPEN SYSTEM:

In an open system the entropy is increased because the mass that crosses the boundary of the system has entropy. Thus for an open system, we may write,

$$dS \geq \frac{\delta Q}{T} + \delta m_i s_i - \delta m_e s_e \text{ ----- (1)}$$

Where, δm_i and δm_e are the masses entering and leaving the system & s_i, s_e are the entropies. As the mass δm_i enters the system, the entropy is increased by an amount $\delta m_i s_i$, similarly as the mass δm_e leaves the system, the entropy decreases by an amount $\delta m_e s_e$

In steady flow process there is no change in the mass of the system and $\delta m_i = \delta m_e = \delta m$. We can write, therefore

$$\delta m (s_e - s_i) \geq \frac{\delta Q}{T} \text{ ----- (2)}$$

For steady flow adiabatic process $s_e \geq s_i$ (since $\delta Q=0$) i.e. in a steady flow adiabatic process the entropy of the fluid leaving must be equal to or greater than the entropy of the fluid coming in. Since the equality sign holds for a reversible process, we conclude that for a reversible steady – flow adiabatic process,

$$s_e = s_i \text{ ----- (3)}$$

IMPORTANT RELATIONS FOR A PURE SUBSTANCE INVOLVING ENTROPY

PURE SUBSTANCE:

A pure substance has a homogeneous and invariable chemical composition even though there occurs a phase change.

The first law for a closed system is given by,

$$\delta Q = dE + \delta W \text{ ----- (1)}$$

In the absence of changes in kinetic and potential energies the equation (1) can be written as

$$\delta Q = dU + \delta W \text{ ----- (2)}$$

For a reversible process $Q = TdS$

Therefore equation (2) becomes

$$TdS = dU + \delta W \text{ ----- (3)}$$

The work done at the boundary of a system during a reversible process is given by

$$\delta W = PdV \text{ ----- (4)}$$

Substituting this in equation (3), we get

$$TdS = dU + PdV \text{ ----- (5)}$$

From equation (5) we realize that it involves only changes in properties and involves no path functions. Therefore we conclude that this equation is valid for all processes, both reversible and irreversible and that it applies to the substance undergoing a change of state as the result of flow across the boundary of the open system as well as to the substance comprises a closed system.

In terms of per unit mass the equation (5) can be written as

$$Tds = du + PdV \text{ ----- (6)}$$

$$dU = d(H - PV)$$

Since $= dH - PdV - VdP$ (since $H = U + PV$)

$$TdS = dH - PdV - VdP + PdV = dH - VdP$$

Therefore $TdS = dH - PdV - VdP + PdV = dH - VdP$

i.e. $TdS = dH - VdP$

In terms of unit mass, $Tds = dh - v dP$

or $ds = \frac{dh - v dP}{T} \text{ ----- (7)}$

PRINCIPLE OF THE INCREASE OF ENTROPY:

Entropy Change for the System + Surroundings

Consider the process shown. Let δQ is the heat transfer from a system at temperature T to the surroundings at temperature T_0 , and δW is the work of this process (either +ve or -ve). Using the principle of increase in entropy

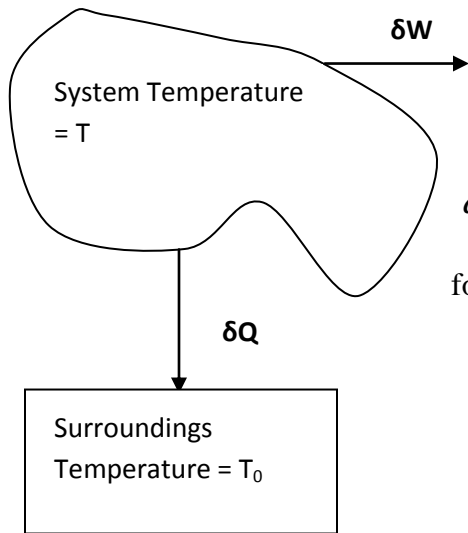

$$dS_{system} \geq -\frac{\delta Q}{T} \text{-----(1)}$$

$$dS_{surroundings} = \frac{\delta Q}{T_0} \text{-----(2)}$$

for a reversible process

The total change of entropy for the combined system

$$dS_{system} + dS_{surroundings} \geq -\frac{\delta Q}{T} + \frac{\delta Q}{T_0}$$

$$\text{or } dS_{system} + dS_{surroundings} \geq \delta Q \left(-\frac{1}{T} + \frac{1}{T_0} \right)$$

The same conclusion can be had for an open system, because the change in the entropy of the system would be

$$dS_{opensystem} \geq -\frac{\delta Q}{T} + \delta m_i s_i - \delta m_e s_e$$

The change in the entropy of the surroundings would be,

$$dS_{surroundings} = \frac{\delta Q}{T_0} - \delta m_i s_i + \delta m_e s_e$$

$$dS_{system} + dS_{surroundings} \geq -\frac{\delta Q}{T} + \frac{\delta Q}{T_0}$$

Therefore,

$$\text{or } dS_{system} + dS_{surroundings} \geq \delta Q \left(-\frac{1}{T} + \frac{1}{T_0} \right) \text{ since } T > T_0 \text{ and it follows}$$

that $-\frac{1}{T} + \frac{1}{T_0} > 0$ and therefore $dS_{system} + dS_{surroundings} \geq 0$

This means that processes involving an interaction of a system and its surroundings will take place only if the net entropy change is **greater than zero** or **in the limit remains constant**. The entropy attains its maximum value when the system reaches a stable equilibrium state from a non equilibrium state.

ENTROPY FOR AN IDEAL GAS :

Let the ideal gas undergoes a change of state from state 1 to state 2. Let T_1, V_1 and T_2, V_2 be the temperatures and volumes at state 1 and 2 respectively.

$$TdS = dU + PdV \text{ ----- (1)}$$

We have, $or dS = \frac{dU}{T} + \frac{P}{T}dV$

Since, $dU = mc_v dT$ and $\frac{P}{T} = \frac{mR}{V}$ where m is the mass and R is the gas constant, we get

$$dS = mc_v \frac{dT}{T} + mR \frac{dV}{V} \text{ therefore}$$

$$S_2 - S_1 = m \int_{T_1}^{T_2} c_v \frac{dT}{T} + mR \int_{V_1}^{V_2} \frac{dV}{V} = m \int_{T_1}^{T_2} c_v \frac{dT}{T} + mR \ln \frac{V_2}{V_1} \text{ ----- (2)}$$

If $c_v = \text{constant}$, then

$$S_2 - S_1 = mc_v \ln \frac{T_2}{T_1} + mR \ln \frac{V_2}{V_1} \text{ ----- (3)}$$

$$TdS = dH - VdP$$

Similarly, we have $or dS = \frac{dH}{T} - \frac{V}{T}dP \text{ ----- (4)}$

Since, $dH = mc_p dT$ & $\frac{V}{T} = \frac{mR}{P}$ we get, $dS = mc_p \frac{dT}{T} - mR \frac{dP}{P}$

$$\text{Therefore, } S_2 - S_1 = m \int_{T_1}^{T_2} c_p \frac{dT}{T} - mR \int_{P_1}^{P_2} \frac{dP}{P} = m \int_{T_1}^{T_2} c_p \frac{dT}{T} - mR \ln \frac{P_2}{P_1} \text{ ----- (5)}$$

If $c_p = \text{constant}$, then $S_2 - S_1 = m c_p \ln \frac{T_2}{T_1} - m R \ln \frac{P_2}{P_1}$ ----- (6)

For general case (process), change of entropy is given by,

$$S_2 - S_1 = m c_v \ln \frac{T_2}{T_1} + m R \ln \frac{V_2}{V_1} = m c_p \ln \frac{T_2}{T_1} - m R \ln \frac{P_2}{P_1}$$
 ----- (7)

or in specific values,

$$s_2 - s_1 = c_v \ln \frac{T_2}{T_1} + R \ln \frac{v_2}{v_1} = c_p \ln \frac{T_2}{T_1} - R \ln \frac{P_2}{P_1}$$
 ----- (8)

SPECIAL CASES:

a) Constant temperature process (Isothermal process), $T = \text{Constant}$

$$S_2 - S_1 = m R \ln \frac{V_2}{V_1} = -m R \ln \frac{P_2}{P_1} \text{ or in specific values } s_2 - s_1 = R \ln \frac{v_2}{v_1} = -R \ln \frac{P_2}{P_1}$$

b) Constant volume process , $V = \text{Constant}$

$$S_2 - S_1 = m c_v \ln \frac{T_2}{T_1} \text{ or in specific values } s_2 - s_1 = c_v \ln \frac{T_2}{T_1}$$

c) Constant pressure process , $P = \text{Constant}$

$$S_2 - S_1 = m c_p \ln \frac{T_2}{T_1} \text{ or in specific values } s_2 - s_1 = c_p \ln \frac{T_2}{T_1}$$

d) Reversible adiabatic process or isentropic process, $S = \text{Constant}$

Change in entropy is zero, $S_2 - S_1 = 0$ or $S_2 = S_1$

e) Polytropic process

$$S_2 - S_1 = c_v \left[\frac{n - \gamma}{n - 1} \right] \ln \frac{T_2}{T_1}$$

Problems on entropy:

Problem No.1. One kg of water at 273 K is brought into contact with a heat reservoir at 373 K. When the water has reached 373 K, find the entropy change of water, the heat reservoir and of the universe.

Solution: Let T_1 be the temperature of water, T_2 be the temperature of heat reservoir. Since reservoir is at higher temperature than that of water, when water is brought into contact with the reservoir heat transfer occurs from reservoir to water and takes place through a finite temperature difference (irreversible). The entropy of water would increase and that of reservoir decrease so that net entropy change of the water and the reservoir together would be **+ve definite**. To find the entropy change of water we have to assume a reversible path between end states, which are at equilibrium.

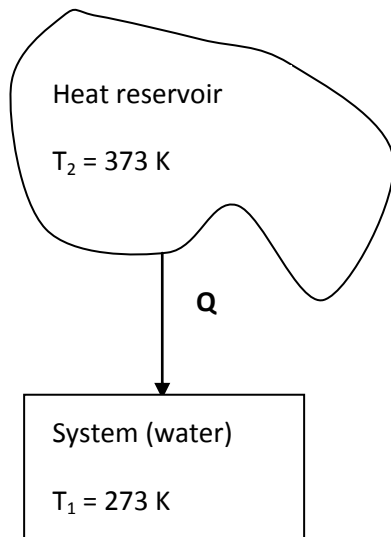

1) Entropy of water

$$\begin{aligned}\Delta S_{\text{water}} &= \int_{T_1}^{T_2} m c_p \frac{dT}{T} = m c_p \ln \frac{T_2}{T_1} \\ &= 1 \times 4.187 \ln \frac{373}{273} = 1.3068 \text{ kJ / K}\end{aligned}$$

2) The temperature of the reservoir remains same irrespective of the amount of the heat withdrawn. Amount of heat absorbed by the system from the reservoir,

$$Q = mc_p (T_2 - T_1) = 1 \times 4,187 (373 - 273) = 418.7 \text{ kJ}$$

Therefore, Entropy change of reservoir,

$$\Delta S_{\text{reservoir}} = -\frac{Q}{T_2} = -\frac{418.7}{373} = -1.1225 \text{ kJ / K} \quad (\text{-ve sign indicates decrease in entropy})$$

3) Entropy change of the universe

$$\Delta S_{\text{universe}} = \Delta S_{\text{water}} + \Delta S_{\text{reservoir}} = 1.3068 - 1.1225 = 0.1843 \text{ kJ / K}$$

Problem No.2. Two kg of air is heated from 27⁰C to 427⁰C while the pressure changes from 100 kPa to 600 kPa. Calculate the change of entropy. $R = 0.257 \text{ kJ / kg K}$, $C_p = 1.005 \text{ kJ / kg K}$.

Solution: Given:

$m = 2 \text{ kg}$	
$T_1 = 27 + 273 = 300\text{K}$	$P_1 = 100 \text{ kPa}$
$T_2 = 427 + 273 = 700\text{K}$	$P_2 = 600 \text{ kPa}$

The general equation used for the calculation of change of entropy is given by,

$$\Delta S_{air} = S_2 - S_1 = m c_p \ln \frac{T_2}{T_1} - m R \ln \frac{P_2}{P_1} = 2 \times 1.005 \ln \left[\frac{700}{300} \right] - 2 \times 0.257 \ln \left[\frac{600}{100} \right]$$

$$= 0.7821 \text{ kJ / K}$$

Problem No.3. Ten grams of water at 20⁰C is converted into ice at -10⁰C at constant atmospheric pressure. Assuming specific heat of liquid water to remain constant at 4.184 J / g⁰C and that of ice to be half of this value, and taking the latent heat of fusion of ice at 0⁰C to be 335 J / g, calculate the total entropy change of the system.

Solution: Given :

$m = 10 \text{ gm}$	
Water is available at temperature $T_1 = 20^{\circ}\text{C} = 293 \text{ k}$ $C_{p(\text{water})} = 4.184 \text{ J / g }^{\circ}\text{C}$ $= 4.184 \text{ kJ / kg }^{\circ}\text{C}$	Ice is to be formed at temperature $T_4 = -10^{\circ}\text{C} = 263 \text{ K}$ $C_{p(\text{ice})} = \frac{1}{2} \times 4.184 \text{ J / g }^{\circ}\text{C}$ $= \frac{1}{2} \times 4.184 \text{ kJ / kg }^{\circ}\text{C}$

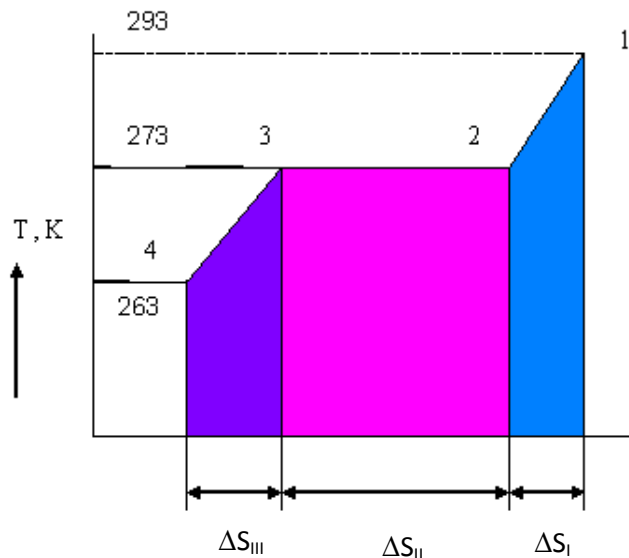

Total entropy change of water (system) as it is converted into ice will be

$$\Delta S_{Total} = \Delta S_I + \Delta S_{II} + \Delta S_{III} \text{ ----- (1)}$$

a) ΔS_I i.e. entropy change of the system as it is cooled from 20 °C to 0 °C.

$$\begin{aligned}\Delta S_I &= \int_{293}^{273} mc_p \frac{dT}{T} = mc_p \ln \frac{273}{293} = \frac{10}{1000} \times 4.184 \ln \frac{273}{293} \\ &= -2.958 \times 10^{-3} \text{ kJ / K}\end{aligned}$$

b) ΔS_{II} i.e. entropy change of water at 0 °C. to become ice at 0 °C

$$\Delta S_{II} = -\frac{mQ_L}{T} = -\frac{10}{1000} \times \frac{335}{273} = -0.0123 \text{ kJ / K}$$

c) ΔS_{III} i.e. entropy change of ice as it is cooled from 0 °C to -10 °C

$$\begin{aligned}\Delta S_{III} &= \int_{273}^{263} mc_{p(ice)} \frac{dT}{T} = mc_{p(ice)} \ln \frac{263}{273} = \frac{10}{1000} \times \frac{4.184}{2} \ln \frac{263}{273} \\ &= -7.807 \times 10^{-4} \text{ kJ / K}\end{aligned}$$

Therefore total entropy change of water as it is converted into ice will be

$$\begin{aligned}\Delta S_{Total} &= \Delta S_I + \Delta S_{II} + \Delta S_{III} = -2.958 \times 10^{-3} + (-0.0123) + (-7.807 \times 10^{-4}) \\ &= -0.01604 \text{ kJ / K}\end{aligned}$$

Problem No.4. A reversible engine as shown in figure during a cycle of operation draws 5MJ from the 400 K reservoir and does 840 kJ of work. Find the amount and direction of heat interaction with other reservoirs.

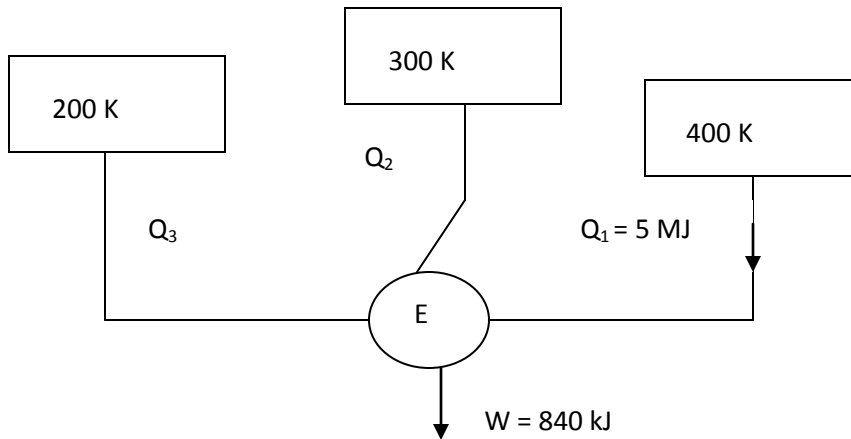

Solution:

Let us assume that Q_2 and Q_3 are the heat rejected by the engine to the reservoir at 300 K and 200 K respectively.

From the Clausius theorem we have $\oint \frac{\delta Q}{T} = 0$ i.e. $\frac{Q_1}{T_1} + \frac{Q_2}{T_2} + \frac{Q_3}{T_3} = 0$ --- (1)

And also, $Q_1 - W = Q_2 + Q_3$ --- (2)

Consider equation (1), $Q_1 = 5 MJ$, $T_1 = 400 K$, $T_2 = 300 K$, $T_3 = 200 K$

Using -ve sign for heat rejected in the equation, we have

$$\frac{5 \times 10^6}{400} - \frac{Q_2}{300} - \frac{Q_3}{200} = 0,$$

$$i.e. 12500 - \frac{Q_2}{300} - \frac{Q_3}{200} = 0$$

$$2Q_2 + 3Q_3 = 12500 \times 600 = 7500000 \text{ --- (3)}$$

and equation (2) gives, $Q_2 + Q_3 = 5 \times 10^6 - 840 \times 10^3 = 4160000$ --- (4)

Solving equations (3) and (4), we get

$$Q_3 = -0.82 \text{ MJ and } Q_2 = +4.98 \text{ MJ}$$

Therefore the direction of heat interaction with the reservoirs are as follows

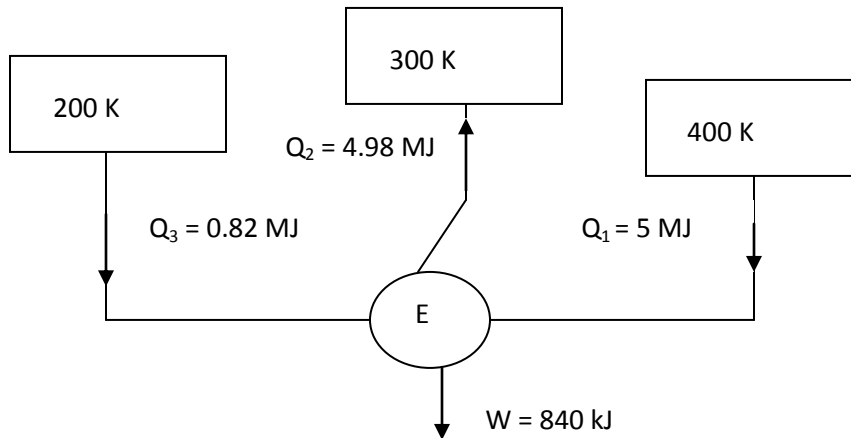

Problem No.5. Two kg of water at 80°C are mixed adiabatically with 3 kg of water at 30°C in a constant pressure process of 1 atmosphere. Find the increase in the entropy of the total mass of water due to mixing process. C_p of water = 4.187 kJ / kg K .

Solution:

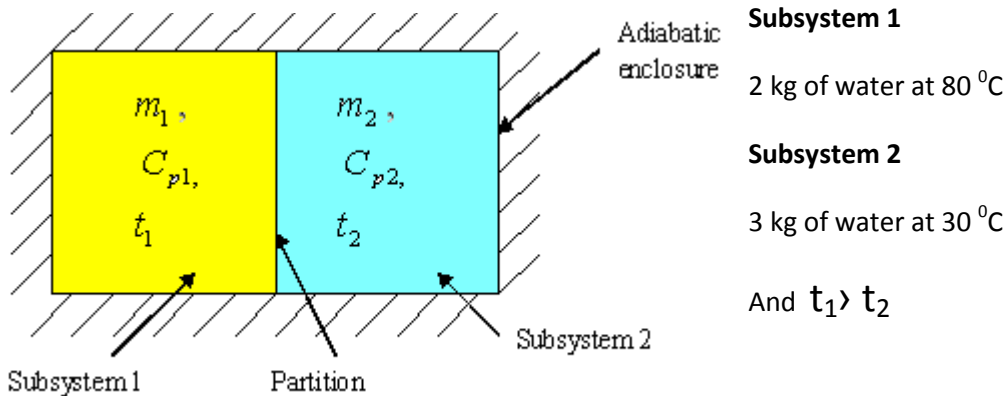

Let t_f be the equilibrium temperature of the mixture of two subsystems i.e. **Subsystem 1** + **Subsystem 2** and the final temperature t_f is such that $t_2 < t_f < t_1$. Since energy interaction is exclusively confined to the two fluids, the system being isolated.

$$m_1 c_{p1} (t_1 - t_f) = m_2 c_{p2} (t_f - t_2) \text{ therefore}$$

$$t_f = \frac{m_1 c_{p1} t_1 + m_2 c_{p2} t_2}{m_1 c_{p1} + m_2 c_{p2}}$$

since $C_{p1} = C_{p2}$, t_f will be given by

$$t_f = \frac{m_1 t_1 + m_2 t_2}{m_1 + m_2} = \frac{(2 \times 80) + (3 \times 30)}{(2 + 3)} = 50 \text{ } ^\circ\text{C}$$

Entropy change for the fluid subsystem 1,

$$\begin{aligned} \Delta S_1 &= \int_{T_1}^{T_f} m_1 c_p \frac{dT}{T} = m_1 c_p \ln \frac{T_f}{T_1} = 2 \times 4.187 \ln \frac{323}{353} \\ &= -0.7437 \text{ kJ/K} \end{aligned}$$

This will be negative since $T_f < T_1$

Entropy change for the fluid subsystem 2,

$$\begin{aligned} \Delta S_2 &= \int_{T_2}^{T_f} m_2 c_p \frac{dT}{T} = m_2 c_p \ln \frac{T_f}{T_2} = 3 \times 4.187 \ln \frac{323}{303} \\ &= 0.8028 \text{ kJ/K} \end{aligned}$$

Increase in the entropy of the total mass of water due to mixing

$$\Delta S = \Delta S_1 + \Delta S_2 = -0.7437 + 0.8028 = 0.0591 \text{ kJ/K}$$

Since ΔS is + ve definite, the mixing process is irreversible.

Problem No.6. A steel tool of mass 0.5 kg at a temperature of $350 \text{ } ^\circ\text{C}$ is plunged suddenly into an insulated vessel containing 10 kg of oil at a temperature of $20 \text{ } ^\circ\text{C}$. After a time the temperature of the contents of the vessel becomes uniform. Assuming the heat transfer to the atmosphere to be zero, and that none of the oil evaporates; evaluate the increase in entropy of the final contents of the vessel. Take C_p of oil = 1.88 kJ/Kg K and C_p of steel = 0.48 kJ/Kg K

Solution: Given

Steel	Oil
$t_s = 350 \text{ } ^\circ\text{C}$	$t_{oil} = 20 \text{ } ^\circ\text{C}$
$m_s = 0.5 \text{ kg}$	$m_{oil} = 10 \text{ kg}$
$C_{steel} = 0.48 \text{ kJ/Kg K}$	$C_{oil} = 1.88 \text{ kJ/Kg K}$

We take the steel and the oil as our system. Applying the principle of conservation of energy for this process, we get

$$Q - W = \Delta U + \Delta KE + \Delta PE \text{ ----- (1)}$$

$$\text{Where } Q = 0, W = 0, \Delta KE = 0, \Delta PE = 0$$

$$\text{Therefore } \Delta U_{steel} + \Delta U_{oil} = 0 \text{ ----- (2)}$$

Let t_f be the final temperature of the contents of the vessel. We have for the energy balance

$$m_s c_{steel} (t_s - t_f) = m_{oil} c_{oil} (t_f - t_o) \text{ therefore}$$

$$t_f = \frac{m_s c_{steel} t_s + m_{oil} c_{oil} t_o}{m_s c_{steel} + m_{oil} c_{oil}} = \frac{(0.5 \times 0.48 \times 350) + (10 \times 1.88 \times 20)}{(0.5 \times 0.48) + (10 \times 1.88)} = 24.16 \text{ } ^\circ \text{C}$$

Now, entropy change for steel is,

$$\begin{aligned} \Delta S_{steel} &= \int_{T_s}^{T_f} m_s c_{steel} \frac{dT}{T} = m_s c_{steel} \ln \frac{T_f}{T_s} = 0.5 \times 0.48 \ln \frac{(24.16 + 273)}{(350 + 273)} \\ &= -0.178 \text{ kJ / K} \end{aligned}$$

And, entropy change for oil is

$$\begin{aligned} \Delta S_{oil} &= \int_{T_o}^{T_f} m_{oil} c_{oil} \frac{dT}{T} = m_{oil} c_{oil} \ln \frac{T_f}{T_o} = 10 \times 1.88 \ln \frac{(24.16 + 273)}{(20 + 273)} \\ &= 0.26504 \text{ kJ / K} \end{aligned}$$

Therefore change in entropy of the final contents of the vessel,

$$\Delta S = \Delta S_{steel} + \Delta S_{oil} = -0.178 + 0.26504 = 0.08704 \text{ kJ / K}$$

Problem No.7. Calculate the entropy change of the universe as a result of the following processes

1. A copper block of mass 0.6 kg and specific heat 150 J/kg K at 100 ⁰C is placed in a lake at 8 ⁰C.
2. Two such blocks at 100 ⁰C and 0 ⁰C are joined together.

Solution:

Given:

$$\text{Case i) } m = 0.6 \text{ kg}, \quad C_c = 150 \text{ J/kg K} = 0.150 \text{ kJ/kg K},$$

$$T_c = 100^\circ\text{C} = 373 \text{ K}, \quad T_l = 8^\circ\text{C} = 281 \text{ K}$$

$$\Delta S_{\text{universe}} = \Delta S_{\text{Copperblock}} + \Delta S_{\text{Lake}}$$

When hot copper block is put into lake, the block shall cool down to the lake temperature since lake is big and treated as sink.

$$\begin{aligned} \text{i) } \Delta S_{\text{Copperblock}} &= m C_c \ln\left(\frac{T_L}{T_C}\right) = 0.6 \times 0.150 \times \ln\left(\frac{281}{373}\right) \\ &= -0.0255 \text{ kJ/K} \end{aligned}$$

Heat lost by Copper Block = Heat gained by lake

$$= m C_c (T_C - T_L)$$

$$= 0.6 \times 0.150 \times (373 - 281) = 8.28 \text{ kJ}$$

$$\Delta S_{\text{Lake}} = \frac{8.28}{281} = 0.0295 \text{ kJ/K}$$

$$\text{Therefore } \Delta S_{\text{universe}} = \Delta S_{\text{Copperblock}} + \Delta S_{\text{Lake}}$$

$$= -0.0255 + 0.0295 = 0.004 \text{ kJ/K}$$

$$\text{Case ii) } m = 0.6 \text{ kg}, \quad C_{c1} = C_{c2} = 150 \text{ J/kg K} = 0.150 \text{ kJ/kg K},$$

$$T_{c1} = 100^\circ\text{C} = 373 \text{ K}, \quad T_{c2} = 0^\circ\text{C} = 273 \text{ K}$$

Let T_m be the equilibrium temperature of the two copper blocks when they communicate. i.e. **Copper block 1 + Copper block 2** and the final temperature T_m is such that $T_{c2} < T_m < T_{c1}$. Since energy interaction is exclusively confined to the two blocks, the system being isolated.

$$mc_{c1}(T_{c1} - T_m) = mc_{c2}(T_m - T_{c2}) \text{ therefore}$$

$$T_m = \frac{mc_{c1}T_{c1} + mc_{c2}T_{c2}}{m c_{c1} + m c_{c2}} = \frac{373 + 273}{2} = 323 \text{ K}$$

$$\begin{aligned} \Delta S_{I \text{ Block}} &= \int_{T_{c1}}^{T_m} mc_{c1} \frac{dT}{T} = mc_{c1} \ln \frac{T_m}{T_{c1}} = 0.6 \times 0.150 \ln \frac{323}{373} \\ &= -0.01295 \text{ kJ / K} \end{aligned}$$

$$\begin{aligned} \Delta S_{II \text{ Block}} &= \int_{T_{c2}}^{T_m} mc_{c2} \frac{dT}{T} = mc_{c2} \ln \frac{T_m}{T_{c2}} = 0.6 \times 0.150 \ln \frac{323}{273} \\ &= 0.01514 \text{ kJ / K} \end{aligned}$$

$$\begin{aligned} \text{Therefore } \Delta S_{\text{universe}} &= \Delta S_{I \text{ block}} + \Delta S_{II \text{ block}} \\ &= -0.01295 + 0.01514 = 0.00219 \text{ kJ / K} \end{aligned}$$

Problem No.8. A heat engine is supplied with 278 kJ / s of heat at a constant fixed temperature of 283 °C and the heat rejections take place at 5 °C. The following results were reported.

i) 208 kJ / s of heat rejected. ii) 139 kJ / s of heat rejected. iii) 70 kJ / s of heat rejected.

Classify which of the results report a reversible cycle, irreversible cycle or impossible cycle.

Solution:

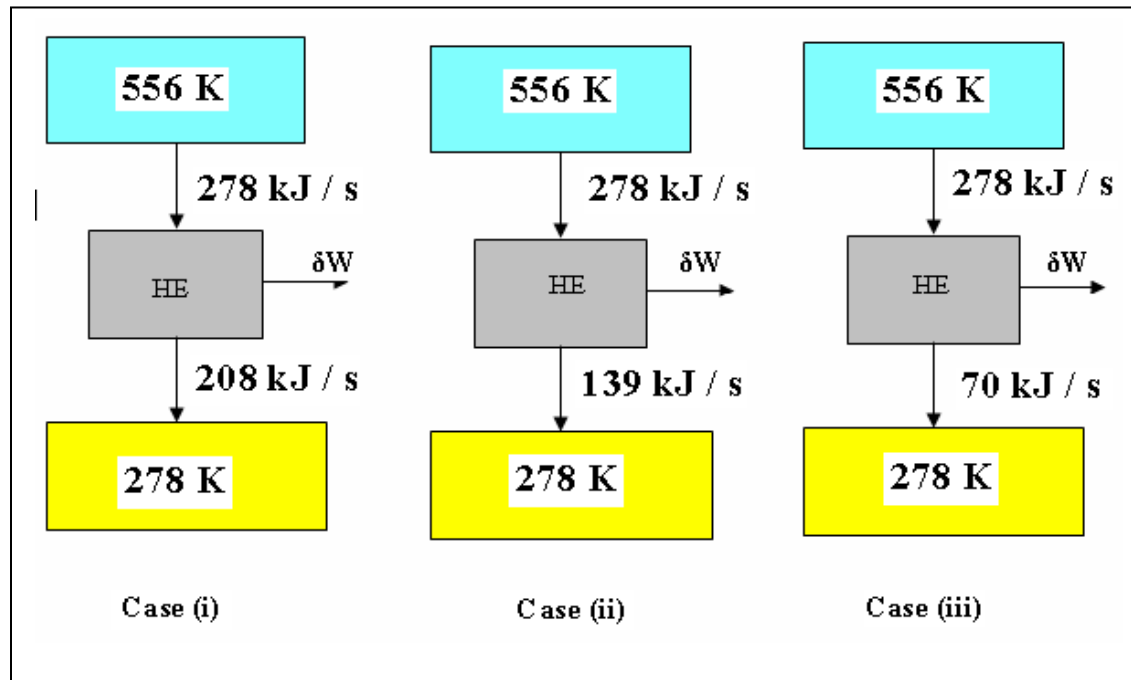

Case (ii)

$$\sum \frac{\delta Q}{T} = \frac{278}{556} - \frac{139}{278} = 0, \quad \text{Since } \sum \frac{\delta Q}{T} = 0 \text{ reversible}$$

Case (iii)

$$\sum \frac{\delta Q}{T} = \frac{278}{556} - \frac{70}{278} = 0.2482, \quad \text{Since } \sum \frac{\delta Q}{T} > 0 \text{ impossible}$$

Problem No.9. 0.5 kg of ice block at -10°C is brought into contact with 5 kg copper block at 80°C in an insulated container. Determine the change in entropy of i) ice block ii) copper block iii) the universe.

Given specific heat of ice = 2 kJ / kg K , Specific heat of water = 4.2 kJ / kg K , Specific heat of copper = 0.5 kJ / kg K , enthalpy of fusion of water at $0^\circ\text{C} = 334 \text{ kJ / kg}$.

Problem No.10. An inventor reports that she has a refrigeration compressor that receives saturated Freon-12 vapor at -20°C and delivers the vapor at 1 MPa , 50°C . The compression process is adiabatic. Does the process described violate the second law?

Solution:

State 1. Condition of Freon -12 at inlet to compressor– **saturated vapor at -20°C**

State 2. Condition of Freon -12 at the exit of compressor – **1 MPa and 50°C**

Referring the Freon -12 tables we get, at state 1, $s_1 = 0.7082 \text{ kJ/kg K}$ and at state 2, $s_2 = 0.7021 \text{ kJ/kg K}$

For a steady state, steady flow, adiabatic process we can write second law as, $s_2 \geq s_1$, but for the given adiabatic process, $s_1 > s_2$ therefore the process involve a violation of the second law and would not be possible.

Problem No.11. One kg of ice at -5°C is exposed to the atmosphere which is at 20°C . The ice melts and comes into thermal equilibrium with the atmosphere. i) Determine the entropy increase of the universe.

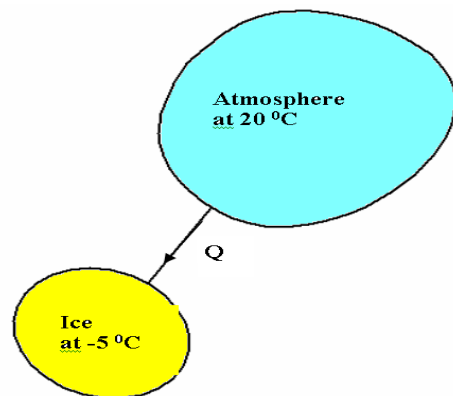

Heat absorbed by ice from the atmosphere is given by,

$$Q = 1 \times 2.093(0 - (-5)) + 1 \times 333.3 + 1 \times 4.187 \times (20 - 0) \\ = 427.5 \text{ kJ}$$

Entropy change of the atmosphere

$$\Delta S_{\text{atmosphere}} = -\frac{Q}{T} = -\frac{427.5}{293} = -1.46 \text{ kJ/K}$$

a) ΔS_I , entropy change of the system(ice) as it is heated from -5°C to 0°C .

$$\Delta S_I = \int_{268}^{273} mc_p \frac{dT}{T} = mc_p \ln \frac{273}{268} = 1 \times 2.093 \ln \frac{273}{268} \\ = -0.0389 \text{ kJ/K}$$

b) ΔS_{II} , entropy change of the system(ice) as it melts at 0°C to become water at 0°C .

$$\Delta S_{II} = \frac{333.3}{273} = 1.22 \text{ kJ/K}$$

c) ΔS_{III} , entropy change of water as it is heated from 0°C to 20°C

$$\Delta S_{III} = \int_{273}^{293} mc_p \frac{dT}{T} = mc_p \ln \frac{293}{273} = 1 \times 4.187 \ln \frac{293}{273} \\ = 0.296 \text{ kJ/K}$$

Therefore total entropy change of ice as it melts into water will be

$$\Delta S_{\text{Total}} = \Delta S_I + \Delta S_{II} + \Delta S_{III} = 0.0389 + 1.22 + 0.296 \\ = 1.5594 \text{ kJ/K}$$

Therefore entropy change of universe will be,

$$(\Delta S)_{\text{universe}} = (\Delta S)_{\text{system}} + (\Delta S)_{\text{atmosphere}} = 1.5594 - 1.46 = 0.0949 \text{ kJ/K}$$

Problem No.12. A 5 kg copper block at a temperature of 200°C is dropped into an insulated tank containing 100 kg of oil at a temperature of 30°C . Find the increase in entropy of the universe due to this process when copper block and the oil reach thermal equilibrium. Assume that the specific heats of copper and oil are respectively 0.4 kJ /Kg K and 2.1 kJ /Kg K .

Solution: Given

Copper block	Oil
$t_c = 200^{\circ}\text{C}$	$t_{oil} = 30^{\circ}\text{C}$
$m_c = 5 \text{ kg}$	$m_{oil} = 100 \text{ kg}$
$C_{copper \text{ block}} = 0.4 \text{ kJ /Kg K}$	$C_{oil} = 2.1 \text{ kJ /Kg K}$

We take the copper block and the oil as our system. Applying the principle of conservation of energy for this process, we get

$$Q - W = \Delta U + \Delta KE + \Delta PE \text{ ----- (1)}$$

$$\text{Where } Q = 0, W = 0, \Delta KE = 0, \Delta PE = 0$$

$$\text{Therefore } \Delta U_{copperblock} + \Delta U_{oil} = 0 \text{ ----- (2)}$$

Let t_m be the final temperature of the contents of the tank. We have for the energy balance

$$m_c c_{copperblock} (t_c - t_m) = m_{oil} c_{oil} (t_m - t_o) \text{ therefore}$$

$$t_f = \frac{m_c c_{copperblock} t_c + m_{oil} c_{oil} t_o}{m_c c_{copperblock} + m_{oil} c_{oil}} = \frac{(5 \times 0.4 \times 200) + (100 \times 2.1 \times 30)}{(5 \times 0.4) + (100 \times 2.1)} = 31.6^{\circ}\text{C}$$

Now, entropy change for copper block is,

$$\begin{aligned} \Delta S_{copperblock} &= \int_{T_c}^{T_m} m_c c_{copperblock} \frac{dT}{T} = m_c c_{copperblock} \ln \frac{T_m}{T_c} = 5 \times 0.4 \ln \frac{(31.6 + 273)}{(200 + 273)} \\ &= -0.8802 \text{ kJ / K} \end{aligned}$$

Now, entropy change for oil is

$$\begin{aligned} \Delta S_{oil} &= \int_{T_o}^{T_m} m_{oil} c_{oil} \frac{dT}{T} = m_{oil} c_{oil} \ln \frac{T_m}{T_o} = 100 \times 2.1 \ln \frac{(31.6 + 273)}{(30 + 273)} \\ &= 1.106 \text{ kJ / K} \end{aligned}$$

Therefore change in entropy of the final contents of the vessel,

$$\Delta S = \Delta S_{copperblock} + \Delta S_{oil} = -0.8802 + 1.106 = 0.2258 \text{ kJ / K}$$

PROPERTY DIAGRAMS WITH ENTROPY AS A COORDINATE:

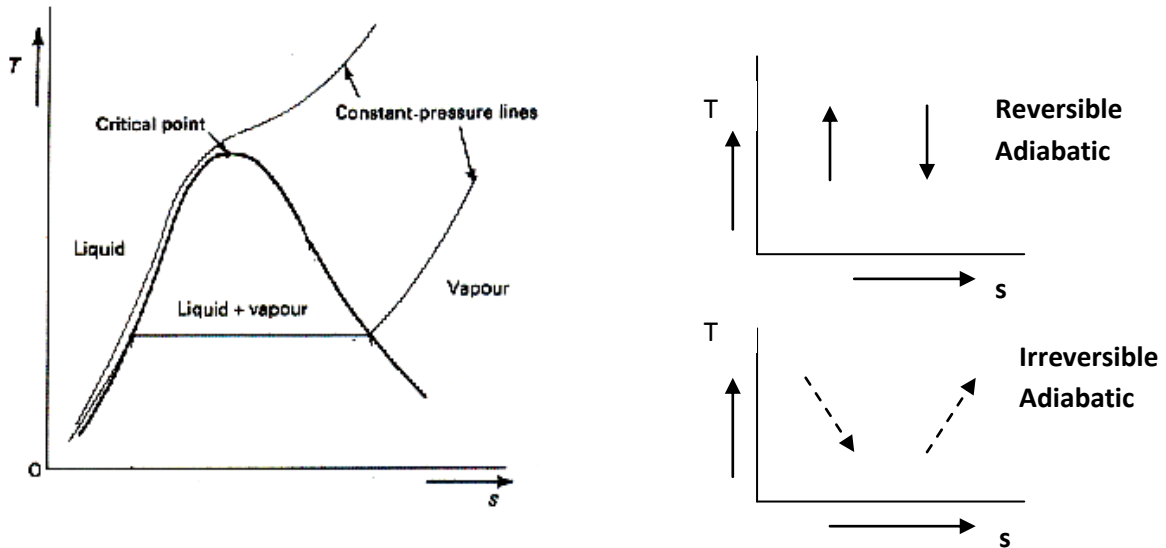

This diagram is useful to analyze the nature of the thermodynamic systems to visualize the changes of state that occurs in various processes. This diagram possesses the following features.

1. Area on the diagram have the dimensions of heat
2. In the mixed-phase region, the constant pressure lines are horizontal
3. In a reversible process the area under the curve is equal to the heat transfer in the corresponding process
4. Vertical lines represents isentropic processes
5. In a reversible cycle, the area enclosed by the curve representing the process is equal to the net heat transfer to the fluid and so, from the first law is also equal to the net work.

If the substance executes a Carnot cycle, its path on the T-s diagram is a rectangle.

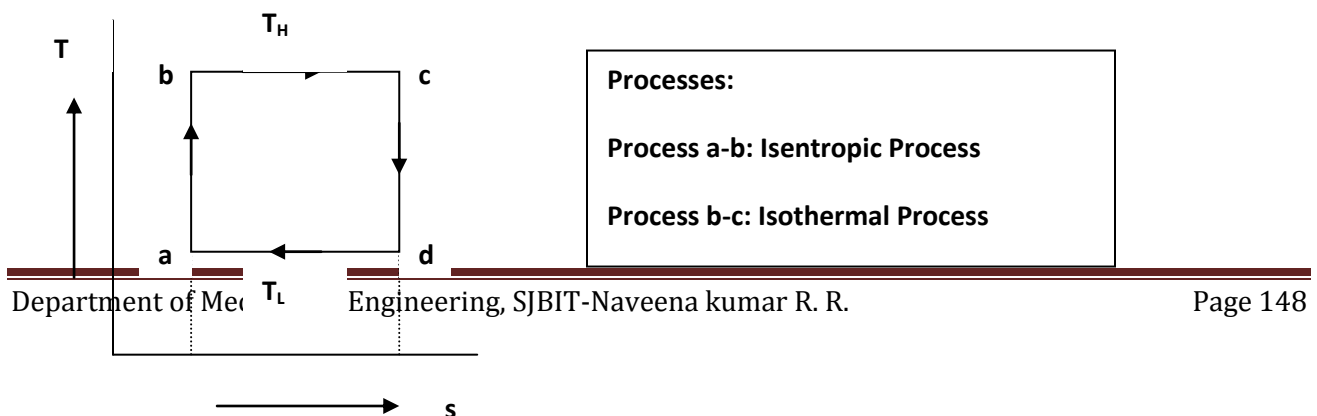

Efficiency of the Carnot engine is given by,

$$\eta_{th} = \frac{\text{Area } abcda}{\text{Area } fbcef} = \frac{T_H(s_2 - s_1) - T_L(s_2 - s_1)}{T_H(s_2 - s_1)} = \frac{T_H - T_L}{T_H} = 1 - \frac{T_L}{T_H}$$

An irreversible process is represented by a line tending to the right, for this entropy always increases.

THE ENTHALPY –ENTROPY (h-s) diagram or MOLLIER diagram

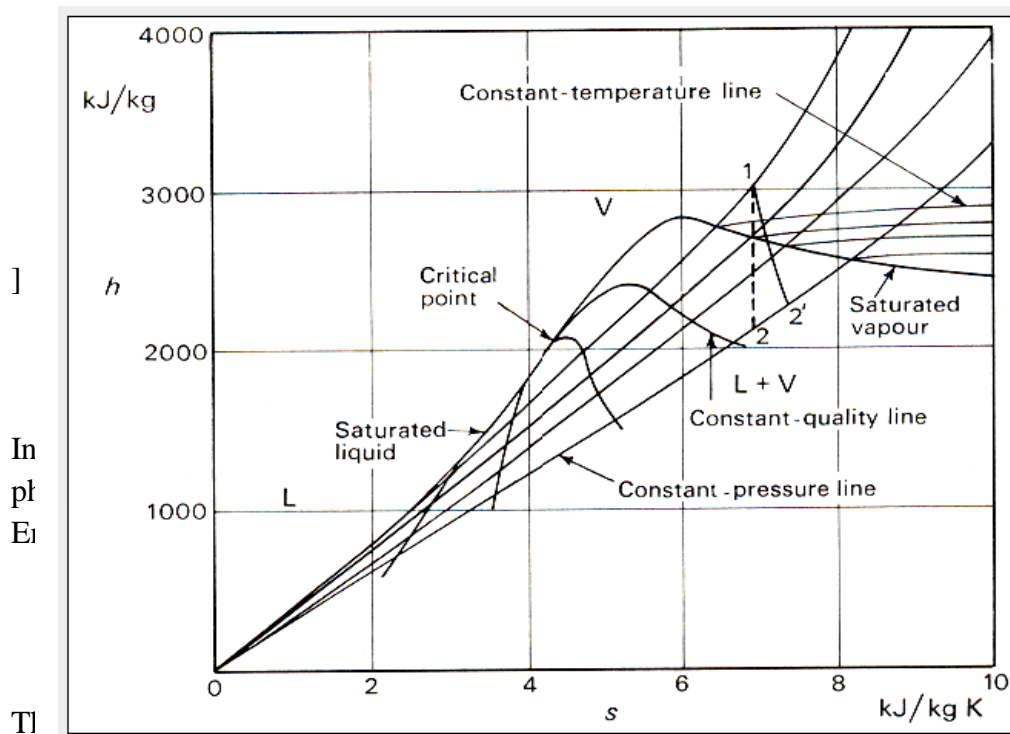

in the two-
approaches
rature.

2. Every system has entropy
3. Entropy is an extensive property
4. Entropy is that –it is an index of that portion of energy content in a system that is not available to do work
5. Entropy content of an isolated system is not conserved.

Available and Unavailable energy:

We have,

High Grade Energy	Low Grade Energy
1 Mechanical Work	1 Heat or Thermal energy
2 Electrical Energy	2 Heat derived from nuclear fission or fusion
3 Water power	3 Heat derived from combustion of fossil fuels
4 Wind power	
5 Kinetic Energy of a jet	
6 Tidal power	

The complete conversion of low grade energy, heat into high grade energy, shaft work is impossible. That part of the low grade energy which is available for conversion is called as available energy, while the part which, according to the 2nd law of thermodynamics, must be rejected is known as unavailable energy.

If a cyclic heat engine is considered, the maximum work output obtainable from a certain heat input is called the available energy (A.E.), or the available part of the energy supplied. The minimum energy that has to be rejected to the sink is the unavailable energy (U.E.).

Therefore,

$$Q_1 = A.E. + U.E. \quad \text{or} \quad W_{\max} = Q_1 - U.E. \quad \text{-----(1)}$$

For a reversible cycle,

$$\eta_{rev} = 1 - \frac{T_2}{T_1} \quad \text{-----(2)}$$

For a given temperature T_1 , η_{rev} will increase with the decrease of T_2 . The lowest practicable temperature of heat rejection is the temperature of the surroundings, T_0 .

Therefore, $\eta_{rev} = 1 - \frac{T_0}{T_1}$

And $W_{\max} = \left(1 - \frac{T_0}{T_1}\right) Q_1 \quad \text{-----(3)}$

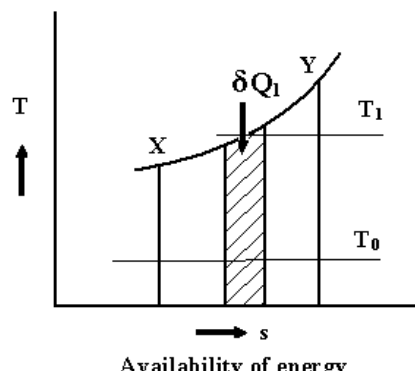
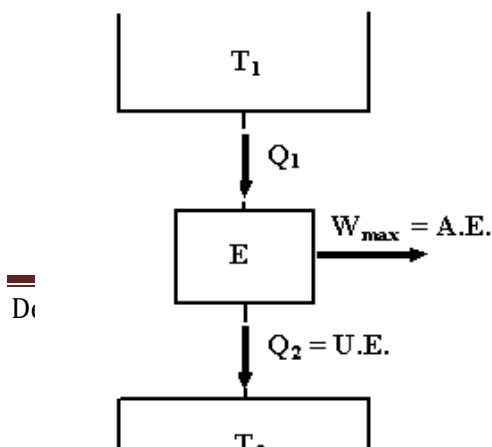

Consider a finite process X-Y , heat is supplied reversibly to a heat engine. Taking an elementary cycle, if δQ_1 is the heat received by the engine reversibly at T_1 , then

$$\delta W_{\max} = \frac{T_1 - T_0}{T_1} \delta Q_1 = \delta Q_1 - \frac{T_0}{T_1} \delta Q_1 = A.E.$$

For the heat engine receiving heat for the whole process X-Y, and rejecting heat at T_0

$$\int_X^Y \delta W_{\max} = \int_X^Y \delta Q_1 - \int_X^Y \frac{T_0}{T_1} \delta Q_1$$

$$W_{\max} = A.E. = Q_{XY} - T_0 (s_Y - s_X)$$

or $U.E. = Q_{XY} - W_{\max}$ i.e. $U.E. = T_0 (s_Y - s_X)$.

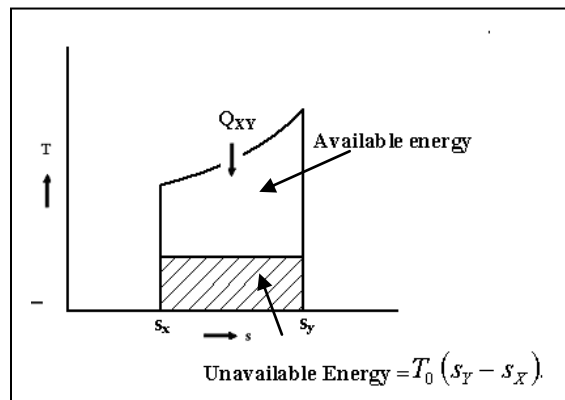

The U.E. is thus the product of the lowest temperature of heat rejection, and the change of entropy of the system during the process of supplying heat.

Module 4**AVAILABILITY, IRREVERSIBILITY AND GENERAL
THERMODYNAMIC RELATIONS****Reversible and Irreversible Processes**

Consider an ideal gas that is held in half of a thermally insulated container by a wall in the middle of the container. The other half of the container is under vacuum with no molecules inside. Now, if we remove the wall in the middle quickly, the gas expands and fills up the entire container immediately, as shown in Figure.

A gas expanding from half of a container to the entire container (a) before and (b) after the wall in the middle is removed.

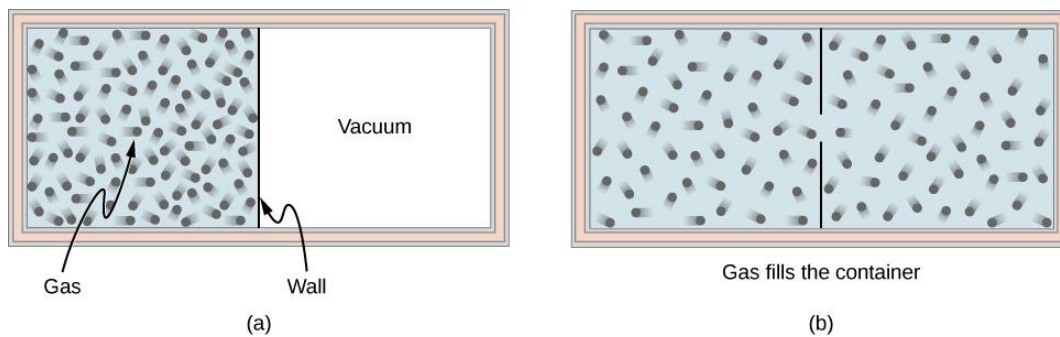

Because half of the container is under vacuum before the gas expands there, we do not expect any work to be done by the system—that is, —because no force from the vacuum is exerted on the gas during the expansion. If the container is thermally insulated from the rest of the environment, we do not expect any heat transfer to the system either, so . Then the first law of thermodynamics leads to the change of the internal energy of the system,

For an ideal gas, if the internal energy doesn't change, then the temperature stays the same. Thus, the equation of state of the ideal gas gives us the final pressure of the gas, where is the pressure of the gas before the expansion. The volume is doubled and the pressure is halved, but nothing else seems to have changed during the expansion.

All of this discussion is based on what we have learned so far and makes sense. Here is what puzzles us: Can all the molecules go backward to the original half of the container in some future time? Our intuition tells us that this is going to be very unlikely, even though nothing we have learned so far prevents such an event from happening, regardless of how small the probability is. What we are really asking is whether the expansion into the vacuum half of the container is *reversible*.

A reversible process is a process in which the system and environment can be restored to exactly the same initial states that they were in before the process occurred, if we go backward along the path of the process. The necessary condition for a reversible process is therefore the quasi-static requirement. Note that it is quite easy to restore a system to its original state; the hard part is to have its environment restored to its original state at the same time. For example, in the example of an ideal gas expanding into vacuum to twice its original volume, we can easily push it back with a piston and restore its temperature and pressure by removing some heat from the gas. The problem is that we cannot do it without changing something in its surroundings, such as dumping some heat there.

A reversible process is truly an ideal process that rarely happens. We can make certain processes close to reversible and therefore use the consequences of the corresponding reversible processes as a starting point or reference. In reality, almost all processes are irreversible, and some properties of the environment are altered when the properties of the system are restored. The expansion of an ideal gas, as we have just outlined, is irreversible because the process is not even quasi-static, that is, not in an equilibrium state at any moment of the expansion.

From the microscopic point of view, a particle described by Newton's second law can go backward if we flip the direction of time. But this is not the case, in practical terms, in a macroscopic system with more than 10^{23} particles or molecules, where numerous collisions between these molecules tend to erase any trace of memory of the initial trajectory of each of the particles. For example, we can actually estimate the chance for all the particles in the expanded gas to go back to the original half of the container, but the current age of the universe is still not long enough for it to happen even once.

An irreversible process is what we encounter in reality almost all the time. The system and its environment cannot be restored to their original states at the same time. Because this is what happens in nature, it is also called a natural process. The sign of an irreversible process comes from the finite gradient between the states occurring in the actual process. For example, when heat flows from one object to another, there is a finite temperature difference (gradient) between the two objects. More importantly, at any given moment of the process, the system most likely is not at equilibrium or in a well-defined state. This phenomenon is called irreversibility.

Let us see another example of irreversibility in thermal processes. Consider two objects in thermal contact: one at temperature T_2 and the other at temperature T_1 , as shown in Figure.

Spontaneous heat flow from an object at higher temperature T_2 to another at lower temperature T_1

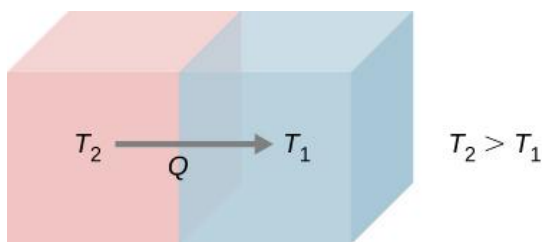

We know from common personal experience that heat flows from a hotter object to a colder one. For example, when we hold a few pieces of ice in our hands, we feel cold because heat has left our hands into the ice. The opposite is true when we hold one end of a metal rod while keeping the other end over a fire. Based on all of the experiments that have been done on spontaneous heat transfer, the following statement summarizes the governing principle:

Second Law of Thermodynamics (Clausius statement)

Heat never flows spontaneously from a colder object to a hotter object.

This statement turns out to be one of several different ways of stating the second law of thermodynamics. The form of this statement is credited to German physicist Rudolf Clausius (1822–1888) and is referred to as the Clausius statement of the second law of

thermodynamics. The word “spontaneously” here means no other effort has been made by a third party, or one that is neither the hotter nor colder object. We will introduce some other major statements of the second law and show that they imply each other. In fact, all the different statements of the second law of thermodynamics can be shown to be equivalent, and all lead to the irreversibility of spontaneous heat flow between macroscopic objects of a very large number of molecules or particles.

Both isothermal and adiabatic processes sketched on a pV graph (discussed in [The First Law of Thermodynamics](#)) are reversible in principle because the system is always at an equilibrium state at any point of the processes and can go forward or backward along the given curves. Other idealized processes can be represented by pV curves; [\(Figure\)](#) summarizes the most common reversible processes.

Summary of Simple Thermodynamic Processes

Process	Constant Quantity and Resulting Fact
---------	--------------------------------------

Isobaric	Constant pressure
----------	-------------------

Isochoric	Constant volume
-----------	-----------------

Isothermal	Constant temperature
------------	----------------------

Adiabatic	No heat transfer
-----------	------------------

Availability, Irreversibility and General Thermodynamic relations

There are many forms in which an energy can exist. But even under ideal conditions all these forms cannot be converted completely into work. This indicates that energy has two parts: Available part, Unavailable part Available energy: is the maximum portion of energy which could be converted into useful work by ideal processes which reduce the system to a dead state (a state in equilibrium with the earth and its atmosphere). Because there can be only one value for maximum work which the system alone could do while descending to its dead state, it follows immediately that „Available energy“ is a property. Unavailable energy: A system which has a pressure difference from that of surroundings, work can be obtained from an expansion process, and if the system has a different temperature, heat can be transferred to a cycle and

work can be obtained. But when the temperature and pressure becomes equal to that of the earth, transfer of energy ceases, and although the system contains internal energy, this energy is 4.1. Available energy referred to a cycle: The available energy (A.E.) or the available part of the energy supplied is the maximum work output obtainable from a certain heat input in a cyclic heat engine (Fig. 6.1). The minimum energy that has to be rejected to the sink by the second law is called the unavailable energy (U.E.), or the unavailable part of the energy supplied.

$$Q_1 = A.E. + U.E.$$

$$\text{or } W_{\max} = A.E. = Q_1 - U.E.$$

For the given values of the source temperature T_1 and sink temperature T_2 , the reversible efficiency,

PURE SUBSTANCE

Pure Substance

A substance that has a fixed chemical composition throughout is called a *pure substance* such as water, air, and nitrogen.

A pure substance does not have to be of a single element or compound. A mixture of two or more phases of a pure substance is still a pure substance as long as the chemical composition of all phases is the same.

Phases of a Pure Substance

A pure substance may exist in different phases. There are three principal phases *solid*, *liquid*, and *gas*.

A phase: is defined as having a distinct molecular arrangement that is homogenous throughout and separated from others (if any) by easily identifiable boundary surfaces.

A substance may have several phases within a principal phase, each with a different molecular structure. For example, carbon may exist as graphite or diamond in the solid phase, and ice may exist in seven different phases at high pressure.

Molecular bonds are the strongest in solids and the weakest in gases.

Solid: the molecules are arranged in a three-dimensional pattern (lattice) throughout the solid.

The molecules cannot move relative to each other; however, they continually oscillate about their equilibrium position.

Liquid: the molecular spacing in liquid phase is not much different from that of the solid phase (generally slightly higher), except the molecules are no longer at fixed positions relative to each other.

Gas: the molecules are far apart from each other, and a molecular order does not exist. Gas molecules move randomly, and continually collide with each other and the walls of the container they are in.

Molecules in the gas phase are at a considerably higher energy level than they are in liquids or solid phases.

Phase-Change Processes of Pure Substances

Consider a process where a pure substance starts as a solid and is heated up at constant pressure until it all becomes gas. Depending on the prevailing pressure, the matter will pass through various phase transformations. At P_0 :

1. Solid
2. Mixed phase of liquid and solid
3. Sub-cooled or compressed liquid (means it is not about to vaporize)
4. Wet vapor or saturated liquid-vapor mixture, the temperature will stop rising until the liquid is completely vaporized.
5. Superheated vapor (a vapor that is not about to condense).

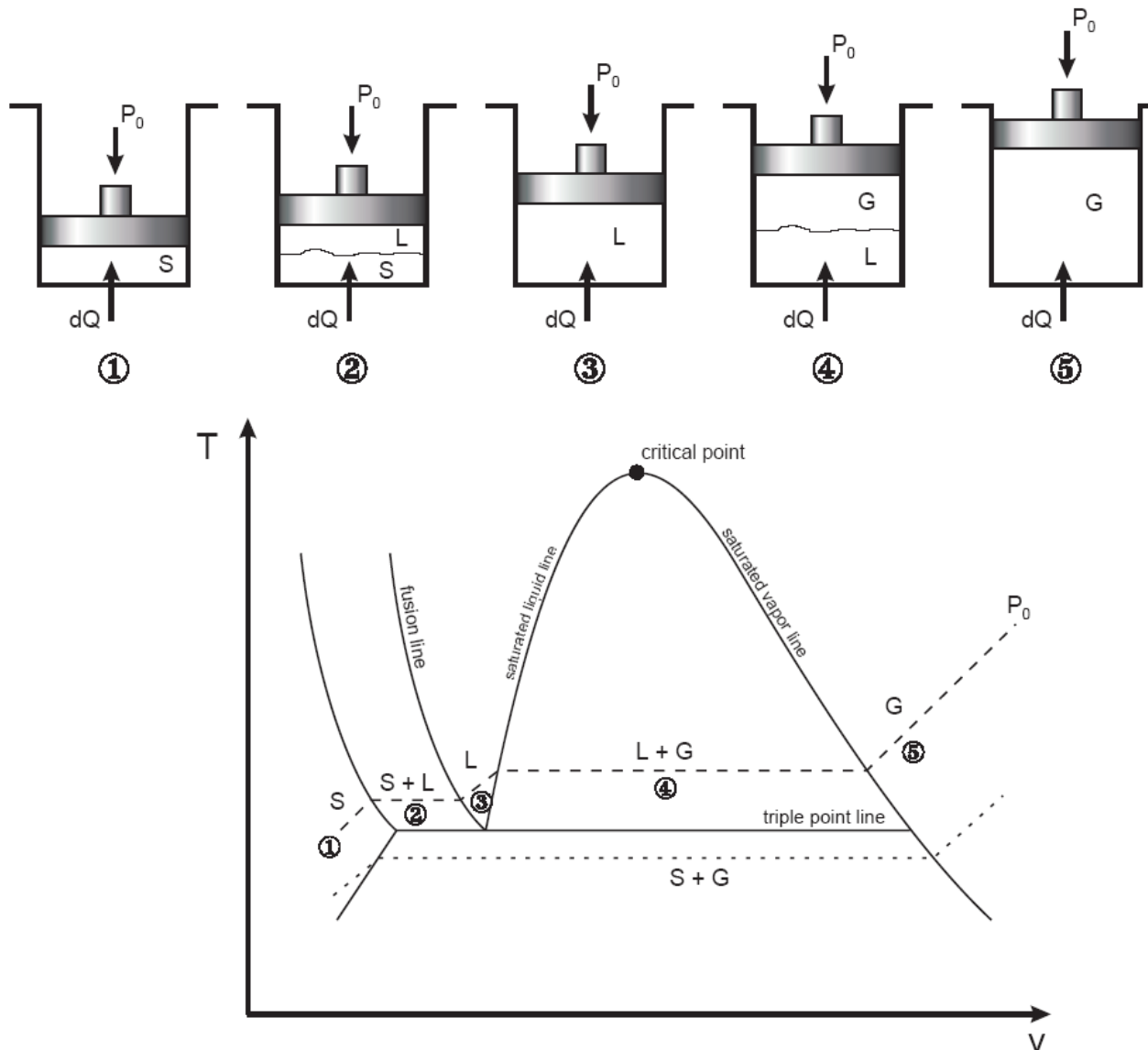

Fig. 1: T-v diagram for the heating process of a pure substance.

- ◆ At a given pressure, the temperature at which a pure substance starts boiling is called the *saturation temperature*, T_{sat} .
- ◆ Likewise, at a given temperature, the pressure at which a pure substance starts boiling is called the *saturation pressure*, P_{sat} .
- ◆ During a phase-change process, pressure and temperature are dependent properties, $T_{\text{sat}} = f(P_{\text{sat}})$.
- ◆ The *critical point* is the point at which the liquid and vapor phases are not distinguishable

- ◆ The “triple point” is the point at which the liquid, solid, and vapor phases can exist together. On P-v or T-v diagrams, these triple-phase states form a line called the *triple line*.

Table 1: Critical and triple point for water and oxygen.

	Critical Point		Triple Point	
	P (atm)	T (K /°C)	P (atm)	T (K /°C)
H ₂ O	218	647.30/(374.14)	0.006	273.17 (0.01)
O ₂	50.136	154.80/(-118.36)	0.0015	54.16/(-219)

Vapor Dome

The general shape of a P-v diagram for a pure substance is very similar to that of a T-v diagram.

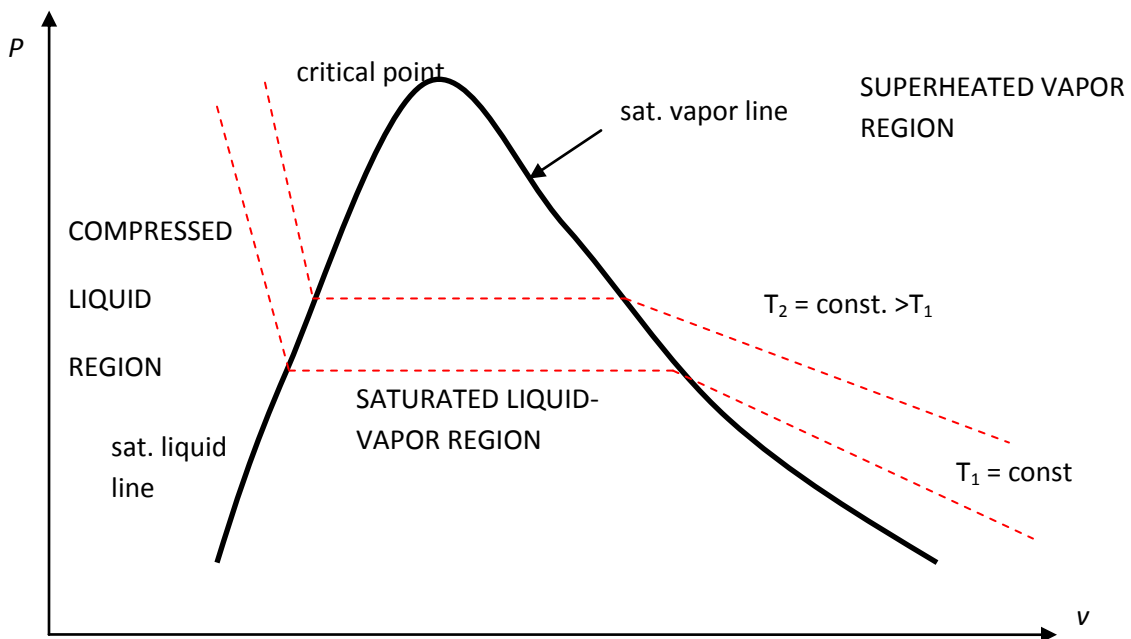

Fig. 2: P-v diagram of a pure substance.

The P-T or Phase Change Diagram

This is called phase diagram since all three phases are separated from each other by three lines. Most pure substances exhibit the same behavior.

- ◆ One exception is water. Water expands upon freezing.

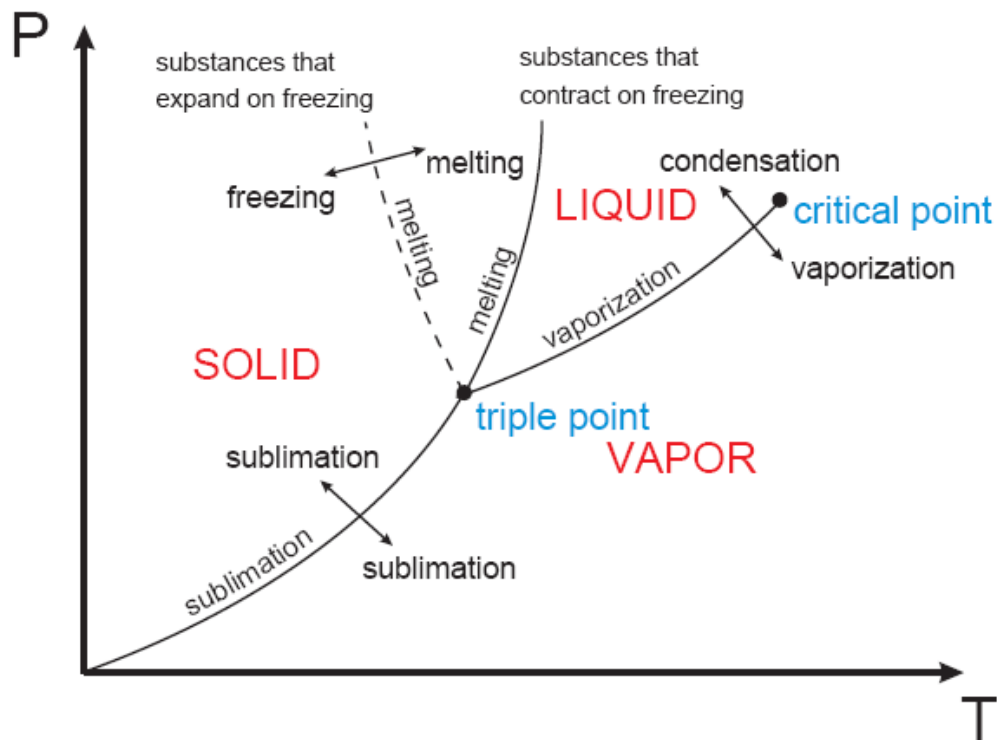

Fig. 3: phase diagram of pure substances.

There are two ways that a substance can pass from solid phase to vapor phase i) it melts first into a liquid and subsequently evaporates, ii) it evaporates directly without melting (sublimation).

- ◆ the *sublimation line* separates the solid and the vapor.
- ◆ the *vaporization line* separates the liquid and vapor regions
- ◆ the *melting or fusion line* separates the solid and liquid.
- ◆ these three lines meet at the *triple point*.
 - if $P < P_{TP}$, the solid phase can change directly to a vapor phase
 - at $P < P_{TP}$ the pure substance cannot exist in the liquid phase. Normally ($P > P_{TP}$) the substance melts into a liquid and then evaporates.
 - matter (like CO_2) which has a triple point above 1 atm sublimate under atmospheric conditions (dry ice)
 - for water (as the most common working fluid) we are mainly interested in the liquid and vapor regions. Hence, we are mostly interested in boiling and condensation.

Property Tables

For most substances, the relationships among thermodynamic properties are too complex to be expressed by simple equations. Thus, properties are frequently presented in the form of tables, see Table A-4.

The subscript “*f*” is used to denote properties of a saturated liquid and “*g*” for saturated vapor. Another subscript, “*fg*”, denotes the difference between the saturated vapor and saturated liquid values of the same property.

For example:

v_f = specific volume of saturated liquid

v_g = specific volume of saturated vapor

v_{fg} = difference between v_g and v_f ($v_{fg} = v_g - v_f$)

Enthalpy: is a property defined as $H = U + PV$ (kJ) or $h = u + Pv$ (kJ/kg) (per mass unit).

Enthalpy of vaporization (or latent heat): represents the amount of energy needed to vaporize a unit mass of saturated liquid at a given temperature or pressure. It decreases as the temperature or pressure increase, and becomes zero at the critical point.

1- Saturated Liquid-Vapor Mixture

During vaporization, a mixture of part liquid part vapor exists. To analyze this mixture, we need to know the proportions of the liquid and vapor in the mixture. The ratio of the mass of vapor to the mass of the total mixture is called *quality*, x :

$$x = \frac{m_{\text{vapor}}}{m_{\text{total}}} \quad m_{\text{total}} = m_{\text{liquid}} + m_{\text{vapor}} = m_f + m_g$$

Saturated liquid-vapor mixture is treated as a combination of two sub-systems (two phases).

The properties of the “mixture” are the *average* properties of the saturated liquid-vapor mixture.

$$V = V_f + V_g$$

$$m_t v_{ave} = m_f v_f + m_g v_g$$

$$m_f = m_t - m_g \rightarrow m_t v_{ave} = (m_t - m_g) v_f + m_g v_g$$

dividing by m_t

$$v_{ave} = (1 - x)v_f + xv_g \quad \text{and} \quad x = m_g / m_t$$

$$v_{ave} = v_f + xv_{fg} \quad (m^3 / kg)$$

or,

$$x = \frac{v_{ave} - v_f}{v_{fg}}$$

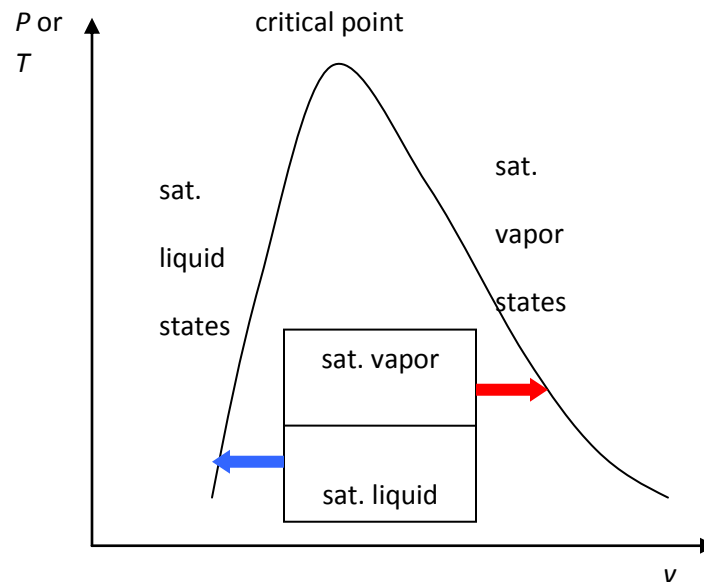

Fig. 4: The relative amounts of liquid and vapor phases (*quality x*) are used to calculate the mixture properties.

Similarly,

$$u_{ave} = u_f + xu_{fg}$$

$$h_{ave} = h_f + xh_{fg}$$

Or in general, it can be summarized as $y_{ave} = y_f + xy_{fg}$. Note that:

$$0 \leq x \leq 1$$

$$y_f \leq y_{ave} \leq y_g$$

Note: pressure and temperature are *dependent* in the *saturated mixture region*.

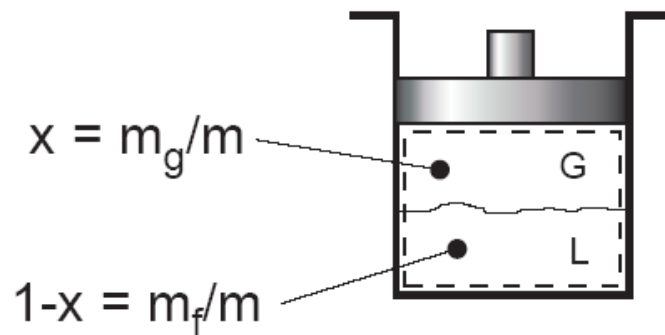

Fig. 5: Quality defined only for saturated liquid-vapor mixture.

Example 1: Saturated liquid-vapor mixture

A closed, rigid container of volume 0.5 m^3 is placed on a hot plate. Initially the container holds a two-phase mixture of saturated liquid water and saturated water vapor at $P_1 = 1 \text{ bar}$ with a quality of 0.5. After heating, the pressure in the container is $P_2 = 1.5 \text{ bar}$. Indicate the initial and final states on a T-v diagram, and determine:

- the temperature, in $^{\circ}\text{C}$, at each state.
- the mass of vapor present at each state, in kg.
- if heating continues, determine the pressure, in bar, when the container holds only saturated vapor.

Solution:

Assumptions:

- Water in the container is a closed system.
- States 1, 2, and 3 are equilibrium states.
- The volume of container remains constant.

Two independent properties are required to fix state 1 and 2. At the initial state, the pressure and quality are known. Thus state 1 is known, as mentioned in the problem. The specific volume at state 1 is found using the given quality:

$$v_1 = v_{f1} + x_1(v_{g1} - v_{f1})$$

From Table A - 5 at $P = 1 \text{ bar} = 100 \text{ kPa}$

$$v_1 = 0.001043 + 0.5 (1.694 - 0.001043) = 0.8475 \text{ m}^3 / \text{kg}$$

At state 2, the pressure is known. Volume and mass remain constant during the heating process within the container, so $v_2=v_1$. For $P_2= 0.15 \text{ MPa}$, Table A-5 gives $v_{f2}= 0.001053$ and $v_{g2}=1.1593 \text{ m}^3/\text{kg}$. Since

$$v_{f2} < v_2 < v_{g2}$$

State 2 must be in the two-phase region as well. Since state 1 and 2 are in the two-phase liquid-vapor region, the temperatures correspond to the saturation temperatures for the given. Table A-5:

$$T_1 = 99.63 \text{ }^\circ\text{C} \text{ and } T_2 = 111.4 \text{ }^\circ\text{C}$$

To find the mass of water vapor present, we first find the total mass, m .

$$m = \frac{V}{v} = \frac{0.5\text{m}^3}{0.8475\text{m}^3 / \text{kg}} = 0.59\text{kg}$$

$$m_{g1} = x_1 m = 0.5(0.59\text{kg}) = 0.295\text{kg}$$

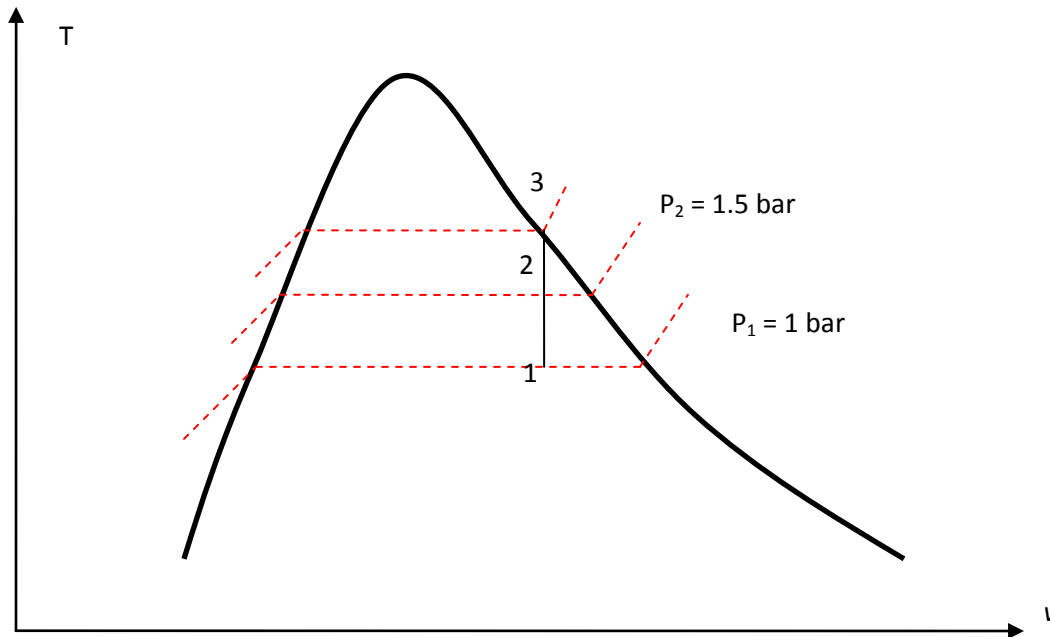

The mass of vapor at state 2 is found similarly using quality x_2 . From Table A-5, for $P_2 = 1.5 \text{ bar}$, we have:

$$x_2 = \frac{v - v_{f2}}{v_{g2} - v_{f2}}$$

$$x_2 = \frac{0.8475 - 0.001053}{1.159 - 0.001053} = 0.731$$

$$m_{g2} = 0.731 (0.59\text{kg}) = 0.431 \text{ kg}$$

If heating continued, state 3 would be on the saturated vapor line, as shown in on the T - v diagram above. Thus, the pressure would be the corresponding saturation pressure.

Interpolating in Table A-5 at $v_g = 0.8475 \text{ m}^3/\text{kg}$, we get $P_3 = 2.11 \text{ bar}$.

2- Superheated Vapor

Superheated region is a single phase region (vapor only), temperature and pressure are no longer dependent. See Table A-6 for superheated vapor properties.

If $T \gg T_{\text{critical}}$ or $P \ll P_{\text{critical}}$, then the vapor can be approximated as an "ideal gas".

3- Compressed (or Sub-cooled) Liquid

The properties of a liquid are relatively independent of pressure (incompressible).

A general approximation is to treat compressed liquid as saturated liquid at the given saturation temperature.

$$y \approx y_{f@T}$$

The property most affected by pressure is enthalpy. For enthalpy use the following approximation:

$$h \approx h_{f@T} + v_f(P - P_{\text{sat}})$$

The Ideal-Gas Equation of State

Any equation that relates the pressure, temperature, and specific volume of a substance is called an *equation of state*.

The simplest and best known equation of state for substances in the gas phase is the *ideal-gas* equation of state.

Gas and *vapor* are often used as synonymous words. The vapor phase of a substance is called a *gas* when it is above the critical temperature. *Vapor* usually implies a gas that is not far from a state of condensation.

It is experimentally observed that at a low pressure the volume of a gas is proportional to its temperature:

$$Pv = RT$$

Where R is the gas constant. The above equation is called the ideal-gas equation of state (ideal gas relation). Since R is a constant for a gas, one can write:

$$R = \frac{P_1 v_1}{T_1} = \frac{P_2 v_2}{T_2}$$

where 1 and 2 denote two states of an ideal gas. The constant R is different for each gas; see Table 2-3 in Cengel book.

$R_u = 8.314 \text{ kJ} / (\text{kmol} \cdot \text{K})$ is the universal gas constant, $R = R_u / M$.

The molar mass, M (kg/kmol): is defined as the mass of one mole of a substance. The mass of a system is equal to the product of its molar mass M and the mole number N :

$$m = MN \quad (\text{kg})$$

See Table A-1 for R and M for several substances. An ideal gas is an *imaginary* substance that obeys the relation $Pv = RT$. It is experimentally observed that the ideal gas closely approximate the P-v-T behavior of real gases at low densities.

- In the range of practical interest, many familiar gases such as air, nitrogen, oxygen, hydrogen, helium, argon, neon, and CO_2 can be treated as ideal gases with negligible error.
- Water vapor (in general see Fig. 4-49 Cengel book), refrigerant vapor in refrigerators **should not be** treated as ideal gases.
- Water vapor at pressures below 10 kPa can be treated as an ideal gas, regardless of temperature.

Compressibility Factor

The assumption of ideal gas relation implies that:

- the gas particles take up negligible volume
- the intermolecular potential energy between particles is small
- particles act independent of one another

However, real gases deviate from ideal gas behavior. This deviation at given temperature and pressure can be accurately accounted for by introduction of a correction factor called the *compressibility factor* Z .

$$Z = \frac{Pv}{RT} \quad \text{or} \quad Pv = ZRT$$

or $Z = v_{\text{actual}} / v_{\text{ideal}}$. Obviously, $Z=1$ for ideal gases.

Gases behave very much the same at temperatures and pressures normalized with respect to their critical temperatures and pressures.

$$P_R = \frac{P}{P_{cr}} \quad \text{and} \quad T_R = \frac{T}{T_{cr}}$$

Here P_R and T_R are called the *reduced pressure* and *temperature*, respectively.

By curve-fitting all the data, the general compressibility chart is obtained which can be used for all gases.

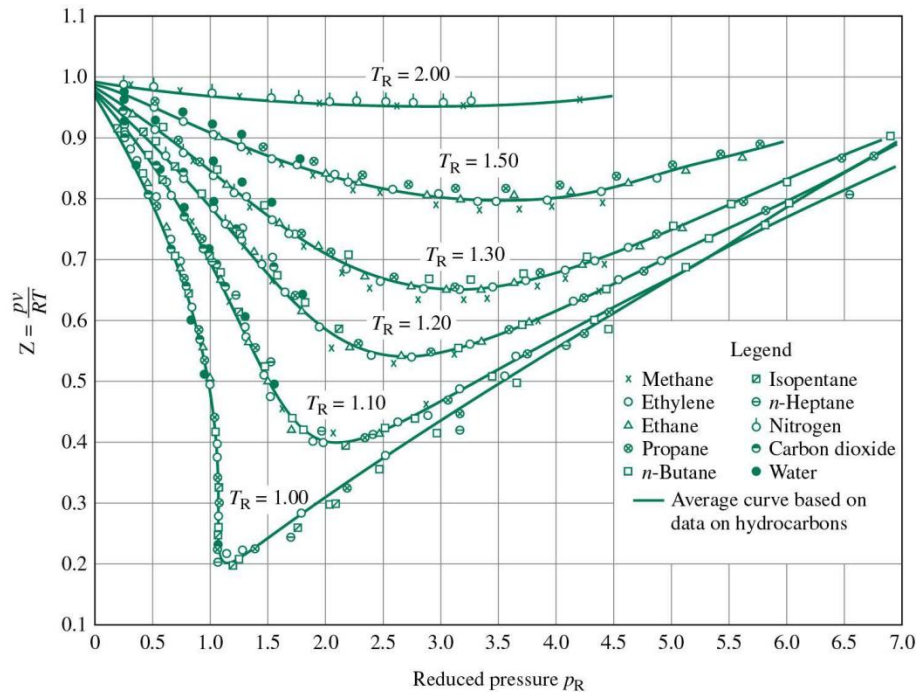

Fig. 6: Z factor, general compressibility chart.

From the Z chart, one can conclude:

- at very low pressure ($P_R \ll 1$), the gases behave as an ideal gas regardless of temperature
- at high temperatures ($T_R > 2$), ideal gas behavior can be assumed.
- the deviation is highest in the vicinity of the critical point.

Example 2: Ideal Gas

Determine the specific volume of R-134a at 1 MPa and 50°C, using (a) ideal gas equation (b) the generalized compressibility chart. Compare the values obtained with the actual value of 0.02171 m³/kg.

Solution:

From Table A-1, for R-134a, $R = 0.0815 \text{ kPa}\cdot\text{m}^3/(\text{kg}\cdot\text{K})$, $P_{cr} = 4.067 \text{ MPa}$, and $T_{cr} = 374.3 \text{ K}$

(a) Ideal gas equation of state

$$v = \frac{RT}{P} = \frac{[0.0815 \text{ kPa}\cdot\text{m}^3 / (\text{kg}\cdot\text{K})](323 \text{ K})}{(1000 \text{ kPa})} = 0.02632 \text{ m}^3 / \text{kg}$$

Comparing with the tabulated value, using ideal gas equation one would get an error of $(0.02632 - 0.02171) / 0.02171 = 0.212$ or 21.2%.

(b) To determine the correction factor Z,

$$P_R = \frac{P}{P_{cr}} = \frac{1 \text{ MPa}}{4.067 \text{ MPa}} = 0.246$$

$$T_R = \frac{T}{T_{cr}} = \frac{323 \text{ K}}{374.3 \text{ K}} = 0.863$$

From Fig. A-28, $Z = 0.84$. Thus,

$$v = Z v_{\text{ideal}} = 0.84 (0.02632 \text{ m}^3/\text{kg}) = 0.02211 \text{ m}^3/\text{kg}$$

The error is less than 2%.

Therefore, in the absence of exact tabulated data, the generalized compressibility chart can be used with confidence.

p-V diagram for water (solid-liquid-vapor region)

If we heat ice at different vapor pressures and note down the corresponding change in volumes, the saturation state points for solid, liquid and vapor (state from which a change of phase may occur without change of pressure and temperature) for different pressures may be obtained on a p-V diagram.

By joining the saturated solid states at various pressures, a **saturated solid line** 'ECA' is obtained. Similarly, by joining all the saturated liquid states with respect to solidification and by joining all the saturated liquid states with respect to vaporization, **saturated liquid lines** 'FG' and 'HG' are obtained. Finally, by joining all the vapor states at various pressures **saturated vapor line** 'HB' is obtained and a phase equilibrium diagram of water on p-v co-ordinates will be formed as shown in Fig.

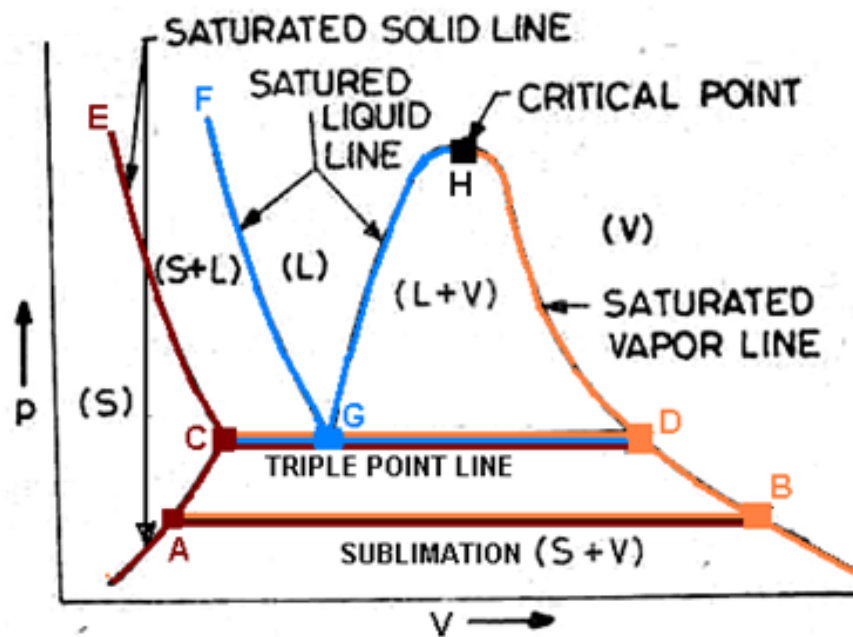

The horizontal portion 'AB' of constant pressure or temperature in Fig. 19.1 represents the transition from saturated solid directly into saturated vapor called **sublimation**. There is obviously one such line 'CGD' in this figure, the part 'CG' of which is the boundary between the liquid-vapor region (L+V) and the solid-vapor region (S+V) and the remaining part 'GD' of which is boundary between the solid-liquid region (S+L) and the solid-vapor region (S+V). This 'CGD' line is called the **triple point**. **Triple point** is the only point at which **three phases of a pure substance coexist**. In the case of ordinary water, the triple point is at a pressure of 4.58 mm of Hg and a temperature of 0.01°C, and the line extends from a volume of 1 cm³/g (saturated liquid) to a volume of 206000 cm³/g (saturated vapor)

p-T DIAGRAM FOR WATER

If the pure substance is heated at low pressure until its triple point (pressure and temperature at which three phases of a pure substance coexist) is reached and while heating the vapor pressure of a solid is measured at various temperatures and then plotted on a p-T diagram, shown in Fig. 19.6. These plotted points represent the coexistence of **solid** and **vapor** and the line through these points is called **sublimation curve**.

If the pure substance at triple point is further heated until the critical point is reached and while heating the vapor pressure of a liquid is measured at various temperatures and then plotted on a p-T diagram, the results will appear as shown in Fig. 19.6. The results of these plotted points represent the coexistence of **liquid** and **vapor** and the line through these points is called **vaporization curve**.

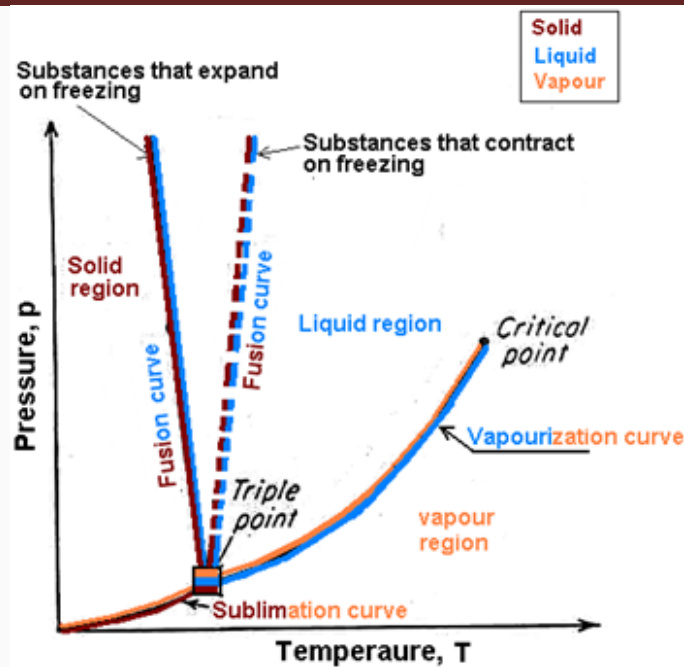

On the other hand, if the substance at the triple point is compressed until there is no vapor left on the resulting mixture of solid and liquid phase and the pressure on the resulting mixture of solid and liquid is increased further, the temperature will have to be changed for equilibrium to exist between the solid and the **liquid**. Measurements of these pressures and temperatures give rise to a third curve on the p-T diagram, starting at the triple point and continuing indefinitely. This is **fusion curve**.

- The points on the **sublimation curve** represent the coexistence of **solid** and **vapor**.
- The points on the **vaporization curve** represent the coexistence of **liquid** and **vapor**.
- The points on the **fusion curve** represent the coexistence of **liquid** and **solid**.

In the particular case of water, the **sublimation curve** is called the **frost line**, the **vaporization curve** is called the **steam line**, and the **fusion curve** is called the **ice line**.

The slopes of the sublimation and the vaporization curves for all substances are positive. The slope of the fusion curve, however, may be positive or negative. The fusion curve of most substances has a positive slope. Water is one of the important exceptions. Any substance, such as water, which expands upon freezing, has a fusion curve with a negative slope (represented by solid line in Figure 19.6), where as opposite is true for substance such as CO₂, which contracts upon freezing i.e. the substance which contracts upon freezing, has a fusion curve with a positive slope (represented by dotted line in Figure 19.6). In other words, in the case of water, the freezing temperature decreases with an increase in pressure while for CO₂, the freezing temperature increases as the pressure increases.

TRIPLE POINT

The pressure and temperature at which **three phases of a pure substance coexist** is called **triple point**. The triple point is merely the point of intersection of the sublimation and vaporization curves, It has been found that on a 'p-T' diagram the triple point is represented by a point (Fig. 19.6) and on a 'p-v' diagram it is a line (Fig. 19.3), and on a 'u-v' diagram it is a triangle. In the case of ordinary water, the triple point is at a pressure of 4.58 mm Hg and a temperature of 0.01°C.

P-V-T Behaviour of Pure Substances

A typical P-T diagram showing the relationship between pressure and temperature of a pure substance is shown below:

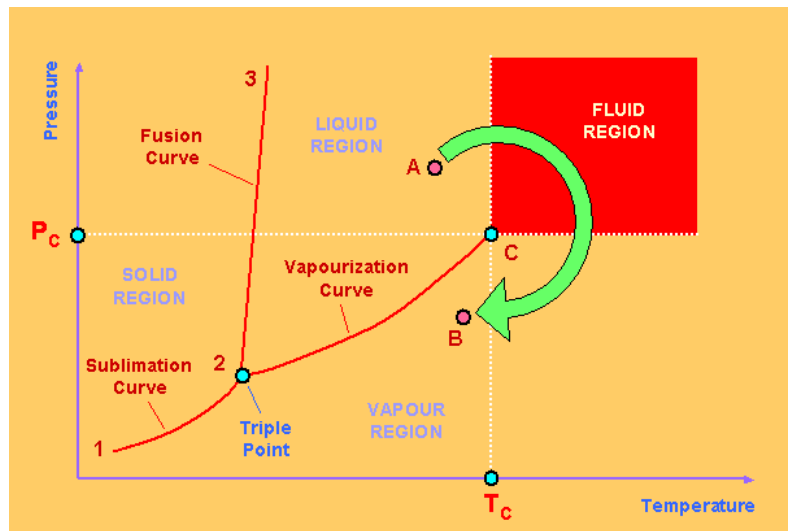

The three lines **1-2**, **2-3** and **2-C** display conditions of P and T at which two phases may co-exist in equilibrium, and are boundaries for the single-phase regions of solid, liquid and vapour (gas).

Line **1-2** is known as the sublimation curve, and it separates the solid from the gas regions. Line **2-3** is known as the fusion curve, and it separates the solid and liquid regions. Line **2-C** is known as the vapourization curve, and it separates the liquid and the gas regions. All three lines meet at Point 2, known as the Triple Point. This is a point where all 3 phases can co-exist in equilibrium.

The vapourization curve **2-C** terminates at point **C**, known as the Critical Point. The pressure and temperature corresponding to this point are known as the critical pressure P_c and critical

temperature T_c respectively. These are the highest pressure and temperature at which a pure substance can exist in vapour-liquid equilibrium.

At the critical point, the liquid and gas phases become indistinguishable, because their properties are the same. This observation is different from ordinary condition whereby the boundary between liquid and gas is very clear. For example, consider a path such as the one from A to B that lead from the liquid region to the gas region without crossing the vapourization curve **2-C**. The transition from liquid to gas is gradual. On the other hand, paths that cross the vapourization curve will involve a vapourization or condensation step, where an abrupt change from liquid to gas occurs.

The shaded area shows the area existing at pressure and temperature greater than P_c and T_c . This region is called the fluid region.

The gas region is sometimes divided into 2 parts, as indicated by the dotted vertical line through temperature T_c . A vapour region is the region to the left of this line and represent a gas that can be condensed either by compression at constant temperature or by cooling at constant pressure. The region everywhere to the right of this line, including the fluid region, is termed supercritical.

P-V Diagram for Pure Substance

The P-T Diagram does not provide any information about volume. It merely displays the phase boundaries on as a function of pressure and temperature. The P-V Diagram - see [Figure](#) below - displays the regions (areas) where 2 phases of solid/liquid, solid/vapour, and liquid/vapour co-exist in equilibrium. For a given P and T, the relative amounts of the phases determine the molar (or specific) volume. On the P-V Diagram, the triple point appears as a horizontal line, where all 3 phases co-exist at a single temperature and pressure.

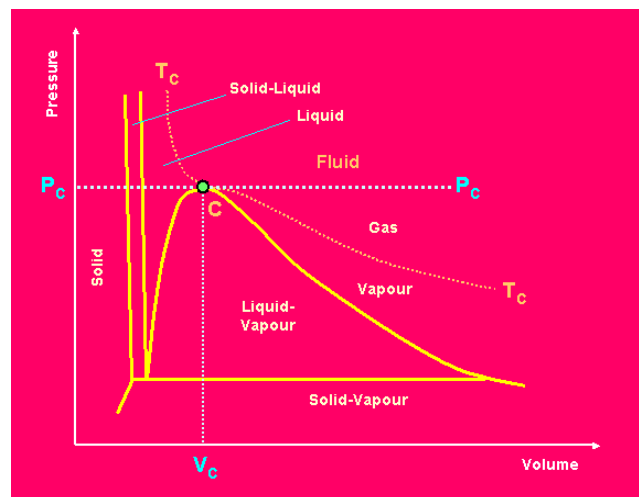

Isotherms are lines of constant temperature and these are superimposed on the P-V Diagram as shown in the Figure below:

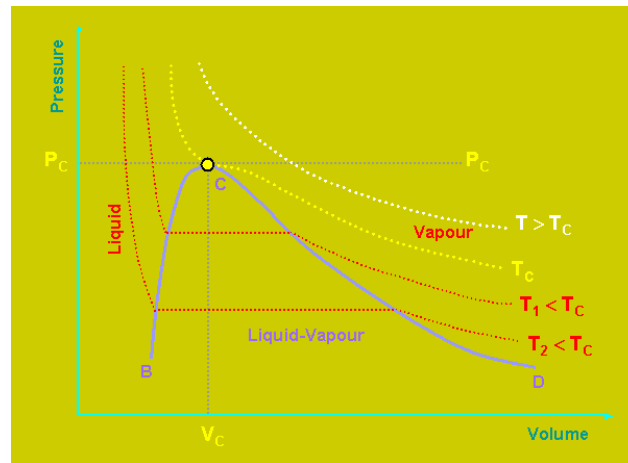

Point **C** is the critical point. V_c is the critical volume at this point. The isotherm labelled $T > T_c$ does not cross a phase boundary. The lines labelled T_1 and T_2 are isotherms for subcritical temperatures, and they consist of 3 segments. The horizontal segment of each isotherm represents all possible mixtures of liquid and vapour in equilibrium, ranging from 100% liquid at the left end (curve **B-C**) to 100% vapour at the right end (curve **D-C**). Curve **B-C** represents saturated liquid at their boiling points, and curve **D-C** represent saturated vapours at their condensation points.

The 2-phase liquid-vapour region lies under the curve **BCD**, whereas subcooled liquid and superheated vapour regions lie to the left and right, respectively. Subcooled liquid exists at temperatures below the boiling point for the given pressure. Superheated vapour exists at temperatures above the boiling point for the given pressure.

Isotherms in the subcooled liquid region are very steep, because liquid volumes change little with large changes in pressure.

The horizontal segments of the isotherms in the 2-phase region become progressively shorter at higher temperatures, being ultimately reduced to a point at **C**, the critical point.

Problems

1. Two kilograms of water at 25°C are placed in a piston cylinder device under 100 kPa pressure as shown in the diagram (State (1)). Heat is added to the water at constant pressure until the piston reaches the stops at a total volume of 0.4 m^3 (State (2)). More heat is then added at constant volume until the temperature of the water reaches 300°C (State

(3)). Determine (a) the quality of the fluid and the mass of the vapor at state (2), and (b) the pressure of the fluid at state (3).

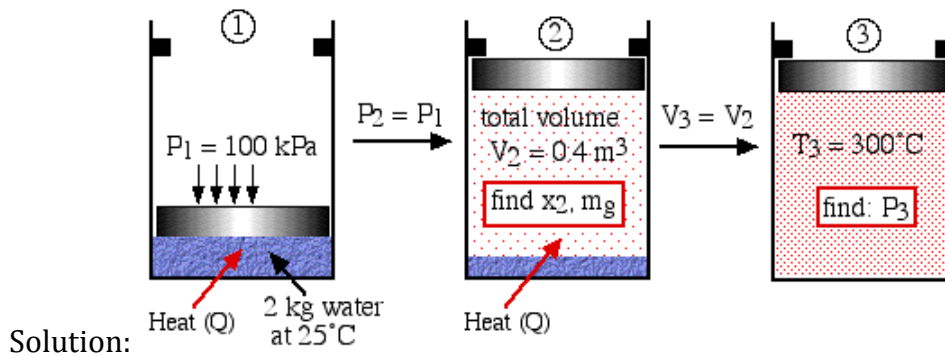

Step 1: Always draw a complete diagram of the states and processes of the problem and include all the relevant information on the diagram. In this case there are three states and two processes (constant pressure and constant volume).

Step 2: In the case of a closed system with a phase change fluid, **always** sketch a T_v or P_v diagram indicating all the relevant states and processes on the diagram. As mentioned above this diagram will not be drawn to scale, however it will help to define the problem and the approach to solution. In the case of steam, as we determine various values from the [steam tables](#) we add these values to the diagram, typically as shown below:

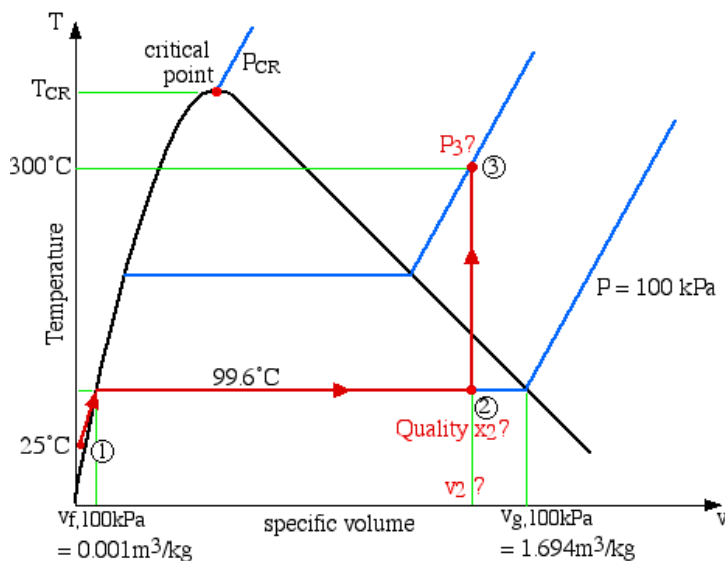

Notice that the T_v diagram is based exclusively on intensive properties, hence mass is not indicated on the diagram. Thus we indicate on the diagram that in order to determine the

quality at state (2) we need to first evaluate the specific volume v_2 , which can then be compared to the saturation values v_f and v_g at the pressure of 100 kPa.

Thus $v_2 = V / m = 0.4 \text{ [m}^3\text{]} / 2 \text{ [kg]} = 0.2 \text{ [m}^3\text{/kg]}$

$$\text{Quality } x_2 = \left[\frac{v_2 - v_f}{v_g - v_f} \right]_{100\text{kPa}} = \left[\frac{0.2 - 0.001}{1.694 - 0.001} \right] = 0.118$$

mass of water vapor at state 2:

$$x = \frac{m_g}{m} \Rightarrow m_g = x.m = 0.118 (2 \text{ kg}) = 0.235 \text{ kg}$$

Concerning state (3), the problem statement did not specify that it is in the superheat region. We needed to first determine the saturated vapor specific volume v_g at 300°C. This value is 0.0216 m³ / kg, which is much less than the specific volume v_3 of 0.2 m³ / kg, thus placing state (3) well into the superheated region. Thus the two intensive properties which we use to determine the pressure at state (3) are $T_3 = 300^\circ\text{C}$, and $v_3 = 0.2 \text{ m}^3\text{/kg}$. On scanning the [superheat tables](#) we find that the closest values lie somewhere between 1.2 MPa and 1.4 MPa, thus we use linear interpolation techniques to determine the actual pressure P_3 as shown below:

Superheat Vapor Tables at 300°C

v	0.2139	$v_3 = 0.2$	0.1823	m ³ /kg
P	1.2	$P_3 ?$	1.4	MPa

$$\frac{P_3 - 1.2}{1.4 - 1.2} = \frac{0.2 - 0.2139}{0.1823 - 0.2139} = 0.440$$

$$\Rightarrow P_3 = 1.29 \text{ MPa}$$

2 - Two kilograms of water at 25°C are placed in a piston cylinder device under 3.2 MPa pressure as shown in the diagram (State (1)). Heat is added to the water at constant pressure until the temperature of the fluid reaches 350°C (State (2)). Determine the final volume of the fluid at state (2).

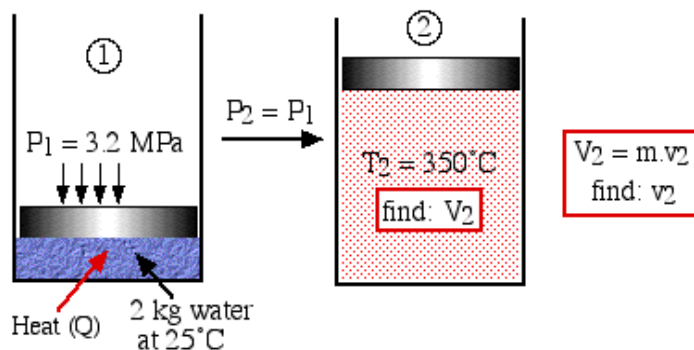

In this example since the pressure is known (3.2 MPa) and remains constant throughout the process, we find it convenient to draw a P - v diagram indicating the process (1) - (2) as follows.

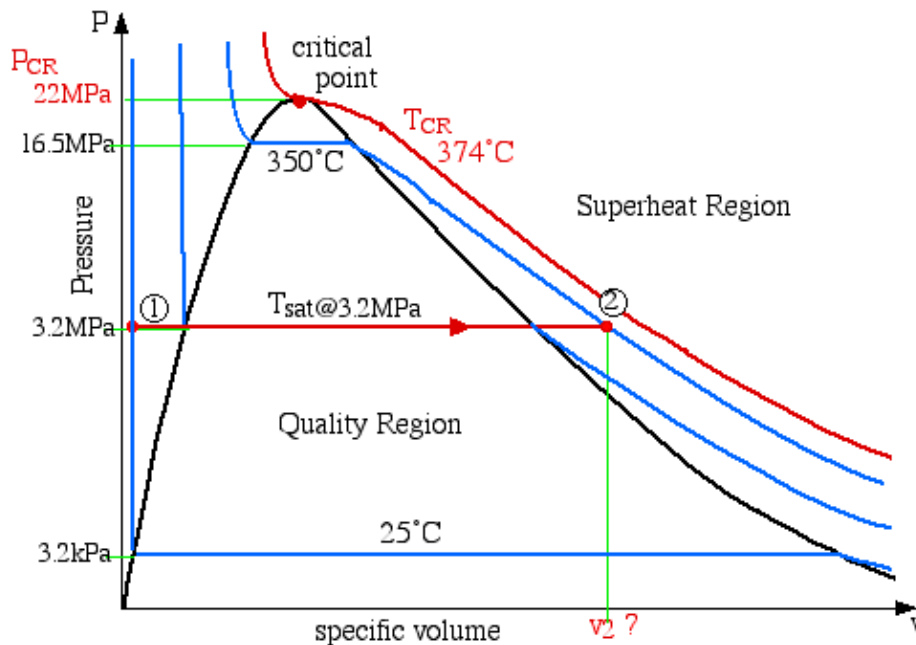

As in the previous example, on scanning the [superheat tables](#) we find that we need to interpolate between pressure $P = 3.0$ MPa and $P = 3.5$ MPa in order to determine the specific volume at the required pressure of 3.2 MPa as follows:

Superheat Vapor Tables

P	3.0	3.2	3.5	MPa
T_{sat}	233.9°C	237.4°C	242.6°C	
v @ 350°C	0.0906	0.085	0.0768	m^3/kg

$$\frac{(T_{\text{sat}} - 233.9)^\circ\text{C}}{(242.6 - 233.9)^\circ\text{C}} = \frac{(3.2 - 3.0) \text{ MPa}}{(3.5 - 3.0) \text{ MPa}} = 0.4$$

$$\Rightarrow T_{\text{sat}} = 237.4^\circ\text{C}$$

$$\frac{(0.0906 - v_2) [\text{m}^3/\text{kg}]}{(0.0906 - 0.0768) [\text{m}^3/\text{kg}]} = \frac{(3.2 - 3.0) \text{ MPa}}{(3.5 - 3.0) \text{ MPa}} = 0.4$$

$$\Rightarrow v_2 = 0.085 [\text{m}^3/\text{kg}]$$

$$V_2 = m \cdot v_2 \Rightarrow 0.170 [\text{m}^3]$$

MEASUREMENT OF DRYNESS FRACTION

Throttling Calorimeter

Principle: The principle of the throttling calorimeter is to throttle the wet steam so that it becomes superheated.

Material: Refer Fig. 26.1. The Throttling Calorimeter consists of inner chamber and outer chamber. The pressure gauge attached to the outer casing and thermometer in inner chamber gives the pressure and temperature of steam after throttling, respectively. In order to prevent any heat transfer from and to the system, the outer chamber is insulated.

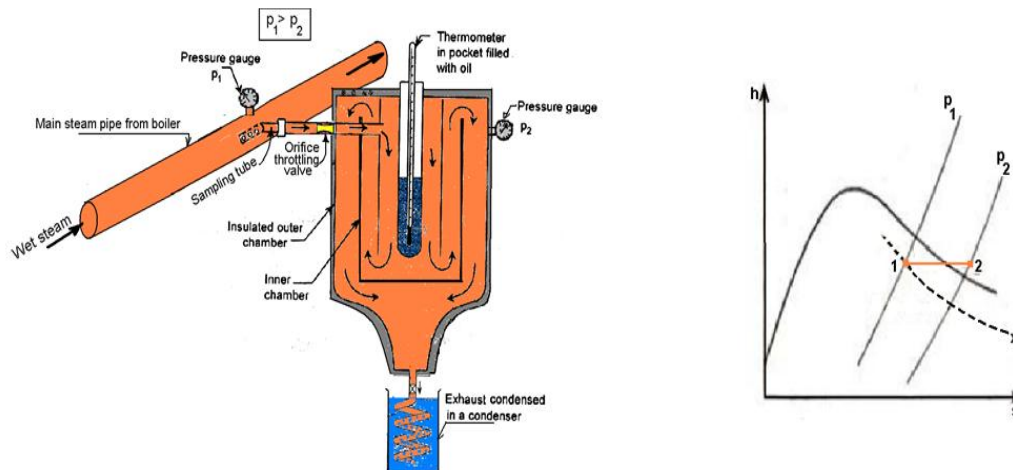

Procedure: A sample of wet steam at pressure ' p_1 ' is taken from the main steam pipe of boiler into the inner chamber of the throttling calorimeter through a sampling tube and orifice throttling valve. This wet steam sample is throttled in orifice throttling valve before it enters into the calorimeter. Normally, pressure desired after throttled is few mm of Hg slightly above atmospheric pressure. The steam of the inner chamber is first allowed to flow down wards then flows upwards and finally turns downwards in the annular space between the inner and outer chamber. This is done so that the steam should flow long enough to ensure constant temperature of throttled steam.

During steam sampling: Note down the following observations:

- Pressure of the wet steam before throttling = p_1 bar
- Pressure of the superheated steam after throttling = p_2 bar
- Temperature of the superheated steam after throttling = $t_{sup,2}$ °C

For the accurate result from the throttling calorimeter, the necessary condition is that the steam should be in a superheated state after throttling. In general, 5°C of superheating is most desirable i.e. 5°C more than the saturation temperature corresponding to recorded pressure after throttling ' p_2 '.

The process '1-2' on h-s diagram in Fig. 26.2, represent the throttling process in orifice throttling valve of throttling calorimeter.

Calculations of dryness fraction of wet steam, x_1 :

Properties of wet steam before throttling at point '1' by using Steam Tables:

Enthalpy of a saturated water corresponding to pressure $p_1 = h_{f,1}$, kJ/kg.

Latent heat of evaporation corresponding to pressure $p_1 = h_{fg,1}$, kJ/kg

Properties of superheated steam after throttling at point '2' by using Steam Tables:

Enthalpy of a superheated steam corresponding to pressure p_2 and temperature $t_{sup,2} = h_{sup,2}$, kJ/kg.

Since during throttling process, the enthalpy remains constant, hence

Enthalpy of wet steam before throttling valve at point '1' corresponding to pressure $p_1 =$ Enthalpy superheated steam after throttling valve at point '2' corresponding to pressure p_2

$$\text{or} \quad h_1 = h_{sup,2} \quad \dots\dots\dots(26.1)$$

Where, Enthalpy of wet steam at point '1' corresponding to pressure p_1 is given by ,

$$h_1 = h_{f,1} + x_1 \cdot h_{fg,1} \quad \dots\dots\dots(26.2)$$

By using equation (26.2) in equation (26.1), we have

$$h_{f,1} + x_1 \cdot h_{fg,1} = h_{sup,2}$$

or

$$\dots\dots\dots(26.3)$$

An alternative method to find ' x_1 ' when superheated steam is treated as an ideal gas:

Then, enthalpy of a superheated throttled steam corresponding to pressure p_2 and temperature $t_{sup,2}$ is calculated by

$$h_{sup,2} = h_{g,2} + C_p(t_{sup,2} - t_{g,2}) \quad , \text{ kJ/kg.} \quad \dots\dots\dots(26.4)$$

where C_p is sp. heat of superheated steam = 2.607 kJ/kg K

By using equations (26.2) and (26.4) in equation (26.1), we have

$$h_{f,1} + x_1 \cdot h_{fg,1} = h_{g,2} + C_p(t_{sup,2} - t_{g,2})$$

or

$$\dots\dots\dots(26.5)$$

With the above equation (26.3) or (26.5) we can easily calculate the value of the dryness fraction.

Drawback

We can not use this method for finding out the dryness fraction of very wet steam because the required 5°C superheated steam after throttling cannot be achieved with the very wet steam.

Problem 1: The following data refer to a throttling calorimeter.

Pressure in the main steam pipe = 10 bar, Pressure after throttling = 1.2 bar, Temperature after throttling = 120°C. Assuming $C_p = 2.303 \text{ kJ/kg K}$ for steam after throttling. Calculate the

- Dryness fraction.
- Minimum degree of wetness which can be shown by this calorimeter for this steam. If the wetness is beyond the range of this calorimeter suggest another method.

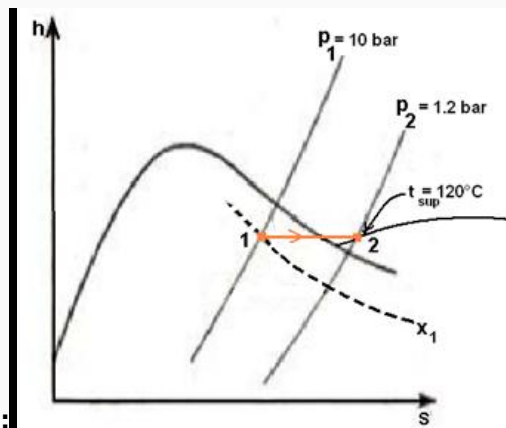

Solution:

Given: Steam at state '1': Pressure in the main steam pipe before throttling, $p_1 = 10 \text{ bar}$:

By using steam table (for dry saturated steam):

For state 1, From steam tables for dry saturated steam at $p_1 = 10 \text{ bar}$, we have

$$h_{f,1} = 763 \text{ kJ/kg}, \quad h_{fg,1} = 2015 \text{ kJ/kg}$$

Given: Steam at state '2': Pressure after throttling, $p_2 = 1.2 \text{ bar}$; Temperature after throttling, $t_2 = 120^\circ\text{C}$;

By using steam table (for dry saturated steam):

For state 2, From steam tables for dry saturated steam at $p_2 = 1.2 \text{ bar}$, we have

$$t_{s,2} = 104.8^\circ\text{C},$$

Since, $t_2 = 120^\circ\text{C} > t_{s,2} = 104.8^\circ\text{C}$ the condition of steam at state '2' is superheated. Therefore, $t_{\text{sup},2} = t_2 = 120^\circ\text{C}$

By using steam table (for superheated steam)

For superheated state 2, From steam tables for superheated steam at $p_2 = 1.2 \text{ bar}$ and $t_{\text{sup},2} = 120^\circ\text{C}$, we have

$$h_{\text{sup},2} = 2714.81 \text{ kJ/kg}$$

Given: Assuming $C_p = 2.303 \text{ kJ/kg K}$ for steam after throttling. Calculate the

(a) Determine the dryness fraction of steam in main steam pipe:

Formula: During throttling process enthalpy remains constant.

$$\text{i.e. } h_1 = h_{\text{sup},2}$$

Since the steam is wet at state '1': $h_1 = h_{f,1} + x_1 \cdot h_{fg,1}$

$$\text{Therefore, } h_{f,1} + x_1 \cdot h_{fg,1} = h_{\text{sup},2}$$

or

$$\text{Answer: Dryness fraction, } x_1 = \frac{h_{\text{sup},2} - h_{f,1}}{h_{fg,1}} = \frac{1714.81 - 763}{2015} = 0.9686$$

(b) Determine the minimum degree of wetness

For minimum degree of wetness, the condition of steam after throttling should be at least 5°C superheated at 1.2 bar pressure.

Therefore superheat temperature at point '2',

$$t_{\text{sup},2} = t_{\text{sat}} \text{ } ^\circ\text{C} + 5^\circ\text{C} = 104.8 + 5 = 109.8^\circ\text{C}$$

By using steam table (for superheated steam)

For superheated state 2, From steam tables for superheated steam at $p_2 = 1.2 \text{ bar}$ and $t_{\text{sup},2} = 109.8^\circ\text{C}$, we have

$$h_{\text{sup},2} = 2687 \text{ kJ/kg}$$

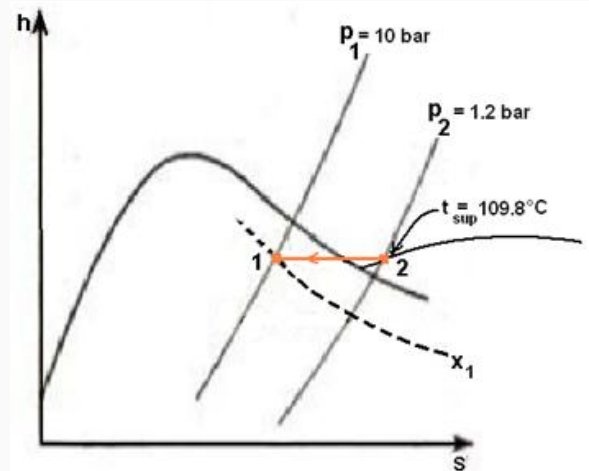

Formula: Since, during throttling process enthalpy remains constant.

$$\text{i.e. } h_1 = h_{\text{sup},2}$$

$$\text{or } h_{f,1} + x_1 \cdot h_{fg,1} = h_{\text{sup},2} \text{ (as condition of steam at point '1' is wet)}$$

or

Answer: The minimum degree of wetness

$$x_1 = \frac{2687 - 763}{2015} = 0.9582$$

If the dryness fraction is lower than 95.28%, a combination of separating and throttling calorimeter will be used.

COMBINED SEPARATING AND THROTTLING CALORIMETER

A combined separating and throttling calorimeter is used to remove the drawback of Separating Calorimeter (i.e. water particles from wet steam are not fully separated) and the drawback of Throttling Calorimeter (i.e. not suitable for very wet steam).

Principle: In this calorimeter

- The moisture from wet steam sample is first removed in separating calorimeter, so that dryness fraction of wet steam sample is increased above 0.95 before steam sample is entering into throttling calorimeter. During this process pressure and temperature remains constant.
- The sample coming out from separating calorimeter is then passed through throttling calorimeter where it expands to superheated steam.

Material: Refer Fig. 26.2. It consists of a combined separating calorimeter and throttling calorimeter as discussed in previous sections.

Procedure: A sample of wet steam from main steam pipe (represented by point 'A' in Fig. 26.2) is first enters the separating calorimeter through a sampling tube. While passing through separating calorimeter, most of the moisture from wet steam is separated out and collected in the inner chamber of the separating calorimeter where it is measure with scale. Now, comparatively dry steam having dryness fraction above 0.95 from separating calorimeter (represented by point 'B' in Fig. 26.2) is passed into throttling calorimeter through throttling valve where it expands to superheated steam (represented by point 'C' in Fig. 26.2). The superheated steam after passing through throttling calorimeter is then exhausted from throttling calorimeter into a condenser, provided at the bottom of the throttling calorimeter, where it is finally condensed and measured.

The representation of separating-throttling processes of combined separating and throttling calorimeter on T-s and h-s diagrams is shown in Fig.

During steam sampling: Note down the following observations:

- Pressure before throttling = p_1 (say) bar
- Pressure after throttling = p_2 (say) bar
- Temperature of a throttled superheated steam = $t_{\text{sup,C}}$ (say), °C

After steam sampling: Note down the following observations:

- Mass of condensate collected in the container provided at the bottom of throttling calorimeter (i.e. mass of steam coming from separating calorimeter into throttling calorimeter through throttling valve) = M (say),kg
- Mass of water collected in the inner chamber of the separating calorimeter (i.e. mass of water separated in the separating calorimeter = m (say),kg

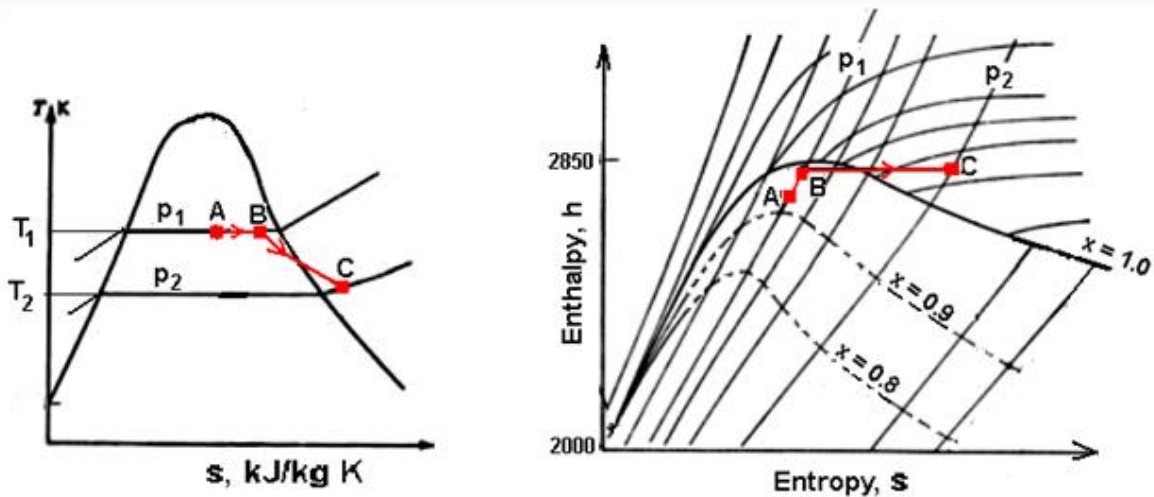
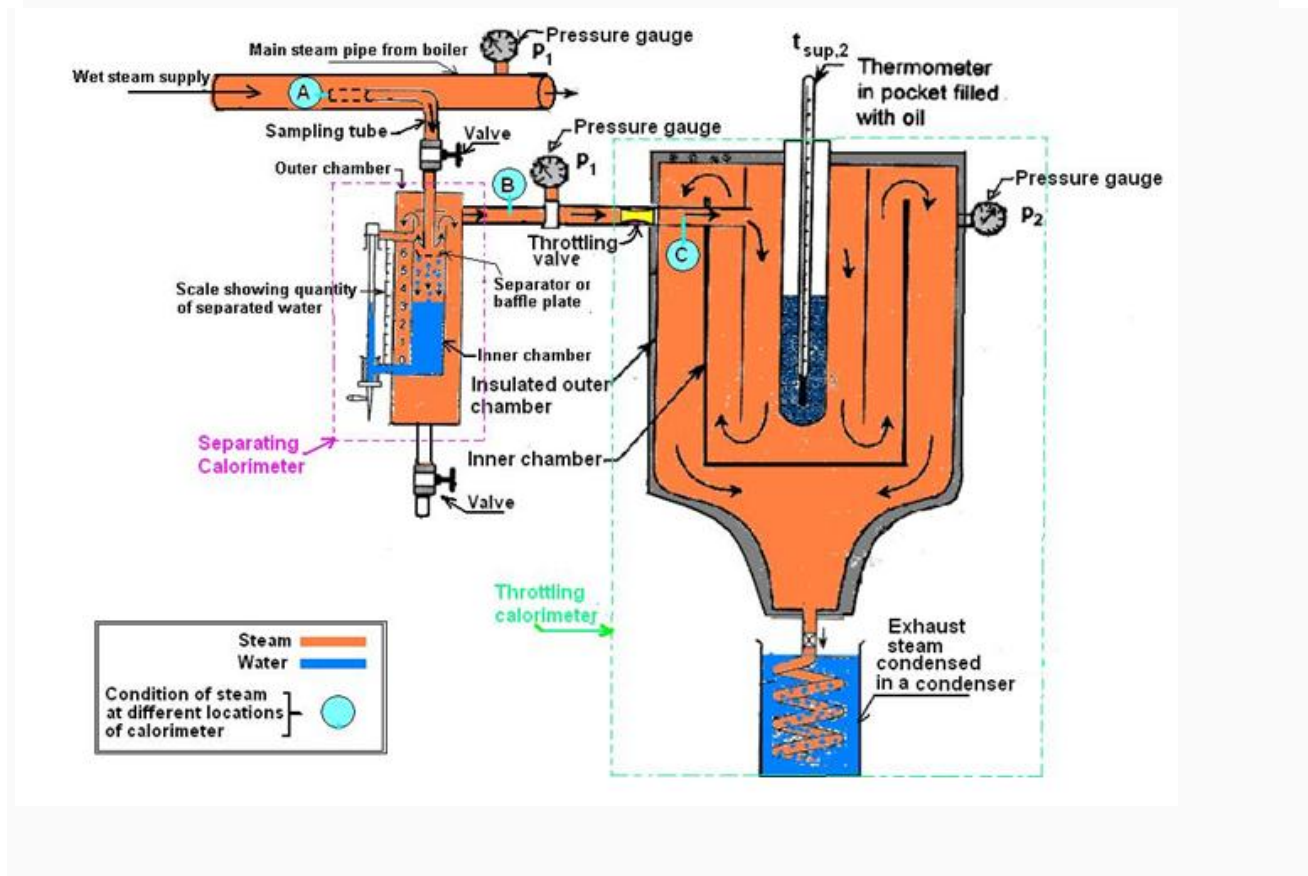

Calculations of dryness fraction of wet steam, x:

- Partial dryness fraction of wet steam coming from main steam pipe, measured by separating calorimeter alone,

$$x_1 = \frac{M}{m+M}$$

- Dryness fraction of steam entering into throttling calorimeter from separating calorimeter through throttling valve, measured by throttling calorimeter alone (by using equation 26.3)

$$x_2 = \frac{h_{\text{sup,C}} - h_{f,B}}{h_{f,g,B}}$$

Where,

$h_{f,B}$ is enthalpy of saturated water at p_1 (from steam tables) , kJ/kg.

$h_{f,g,B}$ is Latent heat of vapourization at p_1 (from steam tables),kJ/kg

$h_{\text{sup,C}}$ is enthalpy of a throttled superheated steam corresponding to pressure p_2 and temperature $t_{\text{sup,C}}$ (from superheated steam table),kJ/kg .

- Mass of dry steam in the wet steam sample collected from main steam pipe = the mass of dry steam entering the throttling calorimeter = $x_2 \cdot M$

Finally, The total dryness fraction of wet steam collected from main steam pipe measure by Combined Separating and Throttling Calorimeter

$$\therefore x = \frac{\text{Mass of dry steam in total mass of wet steam sample collected from main steam pipe}}{\text{Total mass of wet steam sample collected from main steam pipe}} = \frac{M \cdot x_2}{m + M}$$

By using equation (26.6) in above equation, we have

$$x = x_1 \cdot x_2$$

This shows that the dryness fraction of steam measured from combined separating and throttling calorimeter is the product of dryness fraction x_1 and x_2 measured by separating and throttling calorimeter respectively.

Among all methods, this method of determining the dryness fraction of steam is the most satisfactory.

Problem : In a test on a combined separating and throttling calorimeter, the following data were obtained:-

Pressure in the steam main = 14 bar,

Pressure of steam after throttling = 13.2 cm of Hg gauge,

Mass of steam collected in the separator = 0.8 kg/min ,

Discharge from throttling calorimeter = 10 kg/min,

Temperature of steam after throttling = 115°C,

Barometer = 76 cm of Hg.

Calculate (a) the dryness fraction of steam in the main, (b) the velocity of flow in the steam main, if the diameter is 12 cm and the flow of steam is 130 kg/min, (c) the mass of water required to condense the steam after the throttling calorimeter if the temperature rise of the cooling water is 12°C.

Solution:

Given: Steam before throttling (state '1'): Pressure in steam main before throttling, $p_1 = 14$ bar:

By using steam table (for dry saturated steam):

For state 1, From steam tables for dry saturated steam at $p_1 = 14$ bar, we have

$$h_{f,1} = 830 \text{ kJ/kg}, \quad h_{fg,1} = 1960 \text{ kJ/kg}, \quad v_{g,1} = 0.1408 \text{ m}^3/\text{kg}$$

Given: Steam after throttling (state '2'):

Pressure of steam after throttling, $p_2 = 13.2$ cm of Hg gauge

$$p_2 = 76 + 13.2 = 89.2 \text{ cm of Hg.}$$

$$\frac{89.2}{76} \times 1.013 = 1.1889$$

Temperature after throttling, $t_2 = 115^\circ\text{C}$;

By using steam table (for dry saturated steam):

For state 2, From steam tables for dry saturated steam at $p_2 = 1.1889$ bar, we have

$$t_{s,2} = 104.8^\circ\text{C}, \quad h_{g,2} = 2683 \text{ kJ/kg},$$

Since, $t_2 = 115^\circ\text{C} > t_{s,2} = 104.8^\circ\text{C}$ the condition of steam at state '2' is superheated.

Therefore, $t_{\text{sup},2} = t_2 = 115^\circ\text{C}$

By using steam table (for superheated steam)

For superheated state 2, From steam tables for superheated steam at $p_2 = 1.1889$ bar and $t_{\text{sup},2} = 115^\circ\text{C}$, we have

$$h_{\text{sup},2} = 2704.3 \text{ kJ/kg}$$

Given: Mass of steam collected in the separator, $m = 0.8$ kg/min;

Discharge from throttling calorimeter, $M = 10$ kg/min,

(a) Determine the dryness fraction of steam in the main:

Formula: The dryness fraction of steam from separating and throttling calorimeter is calculated by the equation:

$$x = x_1 \cdot x_2$$

where, x_1 = Dryness fraction of steam measured by separating calorimeter,

x_2 = Dryness fraction of steam measured by throttling calorimeter

Finding unknown, x_1 and x_2 :

Dryness fraction of steam measured by separating calorimeter,

$$\frac{M}{m + M} = \frac{10}{0.8 + 10}$$

Dryness fraction of steam measured by throttling calorimeter,

$$x_2 = \frac{h_{\text{sup},2} - h_{f,1}}{h_{f,1}} = \frac{2704.3 - 830}{1960} = 0.956$$

Answer: $x = x_1 \cdot x_2 = 0.9256 \times 0.956 = 0.885$

(b) Determine the velocity of flow in the steam main, if the diameter is 12 cm and the flow of steam is 130 kg/min**Given:**

Diameter of pipe, $d = 12 \text{ cm} = 0.12 \text{ m}$

Formula: From continuity equation,

$$\dot{m} v_1 = A_1 C_1$$

$$\text{or velocity} = C_1 = \frac{\dot{m} v_1}{A_1} = \frac{\dot{m} v_1}{(\pi/4)(d)^2}$$

Finding unknown, v_1

Sp. volume of steam in the main pipe for wet steam, $v_1 = x v_{g,1}$

$$= 0.885 \times 0.1408$$

$$= 0.1246 \text{ m}^3/\text{kg}$$

$$\text{Answer: Velocity} = C_1 = \frac{\dot{m} v_1}{(\pi/4)(d)^2} = \frac{130 \times 0.1246}{(\pi/4)(0.12)^2} = 1432.2 \text{ m/min}$$

(c) Determine the mass of water required to condense the steam after the throttling calorimeter if the temperature rise of the cooling water is 12°C.

Given: Temperature rise of the cooling water, $\Delta t = 12^\circ\text{C}$

Formula: If mass of water be required in the condenser to remove the superheat and latent heat of M mass of steam from throttling calorimeter, then

$$M (h_{\text{sup},2} - t_{s,2}) = x C_p x \Delta t$$

Answer: $M (h_{\text{sup},2} - t_{s,2}) = x C_p x \Delta t$

$$10 (2704.3 - 104.8) = x 12 x 4.18$$

$$\text{or } = \mathbf{518.24 \text{ kg/min}}$$

MODULE 5**IDEAL GASES AND REAL GASES**

Usually, the word 'real gas' refers to a gas that does not function as an ideal gas. The interactions between gaseous molecules can explain their behaviour. Such intermolecular interactions between gas particles are the explanation of why the ideal gas law does not adhere to real gases. A real gas can therefore be characterized as non-ideal gases whose molecules occupy a given amount of space and are capable of interacting with one another. In this article, we will study the real gas definition, real gas equation, and ideal and real gases in detail.

Real Gas Definition

A real gas is defined as a gas that at all standard pressure and temperature conditions does not obey gas laws. It deviates from its ideal behaviour as the gas becomes huge and voluminous. True gases have velocity, mass, and volume. They liquefy when cooled to their boiling point. The space filled by gas is not small when compared to the total volume of gas.

Ideal and Real Gas Equation

An ideal gas is defined as a gas that obeys gas laws at all pressure and temperature conditions. Ideal gases have velocity as well as mass. They have no volume. The volume taken up by the gas is small as compared to the overall volume of the gas. It does not condense and triple-point does not exist.

The ideal gas law is the equation of the state of a hypothetical ideal gas, also called the general gas equation. Under many conditions, it is a reasonable approximation of the behaviour of several gases, but it has many limitations. In 1834, Benoît Paul Émile Clapeyron first described it as a variation of the empirical law of Boyle, the law of Charles, the law of Avogadro, and the law of Gay-Lussac. In an empirical form, the ideal gas law is also written:

$$pV=nRT$$

Real Gas Law

By explicitly including the effects of molecular size and intermolecular forces, the Dutch physicist Johannes van der Waals modified the ideal gas law to explain the behaviour of real gases. The Van der Waal real gas equation is given below-

Real gas law equation,

$$=(P+an^2/V^2) (V-nb)=nRT$$

Where a and b represent the empirical constant which is unique for each gas.

n^2/V^2 represents the concentration of gas.

P represents pressure

R represents a universal gas constant and T is the temperature

Ideal and Real Gases

The difference below shows the properties of real gas and ideal gas, and also the ideal and real gas behaviour.

Ideal Gas	Real Gas
No definite volume	Definite volume
Elastic Collision of particles	Non-elastic collisions between particles
No intermolecular attraction force	Intermolecular attraction force
Does not really exists in the environment and is a hypothetical gas	It really exists in the environment
High pressure	The pressure is less when compared to Ideal gas
Independent	Interacts with others
Obeys $PV = nRT$	Obeys $p + ((n^2a)/V^2) (V - nb) = nRT$

The three fundamental gas laws discover the relationship of pressure, temperature, volume and amount of gas. Boyle's Law tells us that the volume of gas increases as the pressure decreases. Charles' Law tells us that the volume of gas increases as the temperature increases. And Avogadro's Law tell us that the volume of gas increases as the amount of gas increases. The ideal gas law is the combination of the three simple gas laws.

Ideal Gases

Ideal gas, or perfect gas, is the theoretical substance that helps establish the relationship of four gas variables, pressure(P), volume(V), the *amount of gas*(n)and temperature(T). It has characters described as follow:

1. The particles in the gas are extremely small, so the gas does not occupy any spaces.
2. The ideal gas has constant, random and straight-line motion.
3. No forces between the particles of the gas. Particles only collide elastically with each other and with the walls of container.

Real Gases

Real gas, in contrast, has real volume and the collision of the particles is not elastic, because there are attractive forces between particles. As a result, the volume of real gas is much larger than of the ideal gas, and the pressure of real gas is lower than of ideal gas. All real gases tend to perform ideal gas behavior at low pressure and relatively high temperature.

The **compressibility factor (Z)** tells us how much the real gases differ from ideal gas behavior.

$$Z = PV/nRT \quad (\text{Gas Laws.1})$$

For ideal gases, $Z=1$ For real gases, $Z \neq 1$

Boyle's Law

In 1662, Robert Boyle discovered the correlation between *Pressure* (P)and *Volume* (V) (assuming *Temperature*(T) and *Amount of Gas*(n) remain constant):

$$P \propto 1/V \rightarrow PV = x$$

(Gas Laws.2)

where x is a constant depending on amount of gas at a given temperature.

- Pressure is inversely proportional to Volume

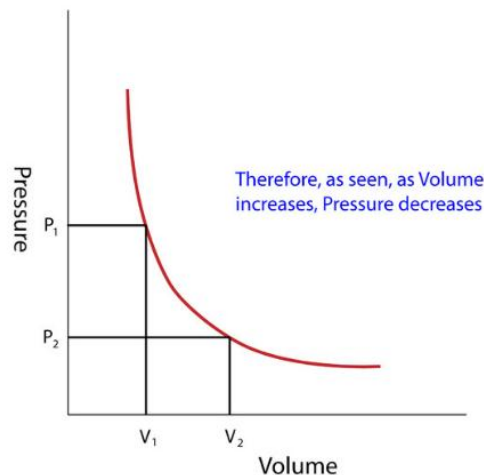

Another form of the equation (assuming there are 2 sets of conditions, and setting both constants to each other) that might help solve problems is:

$$P_1V_1 = P_2V_2$$

V2

Charles' Law

In 1787, French physicist Jacques Charles, discovered the correlation between *Temperature* (T) and *Volume* (V) (assuming *Pressure* (P) and *Amount of Gas* (n) remain constant):

$$V \propto T \rightarrow V = yT$$

where y is a constant depending on amount of gas and pressure. Volume is directly proportional to Temperature

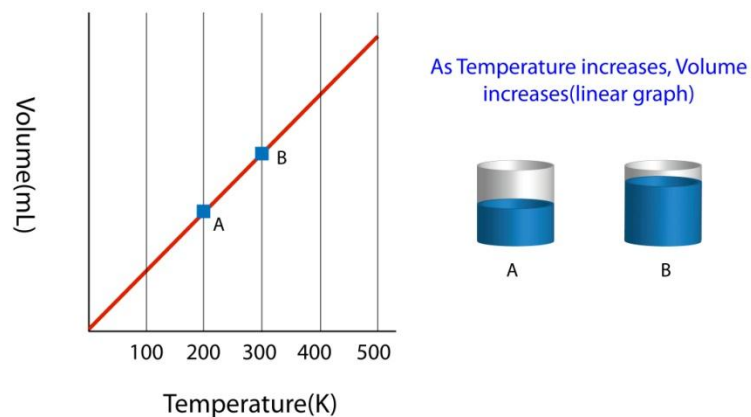

Another form of the equation (assuming there are 2 sets of conditions, and setting both constants to each other) that might help solve problems is:

$$V_1/T_1 = V_2/T_2$$

REAL GASES

Real gases do not obey ideal gas equation under all conditions. They nearly obey ideal gas equation at higher temperatures and very low pressures. However they show deviations from ideality at low temperatures and high pressures.

The deviations from ideal gas behaviour can be illustrated as follows:

The isotherms obtained by plotting pressure, P against volume, V for real gases do not coincide with that of ideal gas, as shown below.

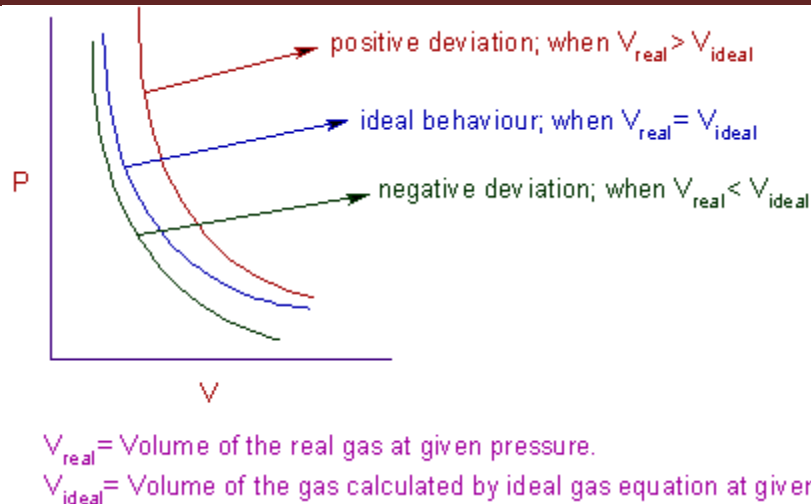

It is clear from above graphs that the volume of real gas is more than or less than expected in certain cases. The deviation from ideal gas behaviour can also be expressed by compressibility factor, Z .

Compressibility factor (Z):

The ratio of PV to nRT is known as compressibility factor.

(or)

The ratio of volume of real gas, V_{real} to the ideal volume of that gas, V_{perfect} calculated by ideal gas equation is known as compressibility factor.

$$Z = \frac{PV_{\text{real}}}{nRT}$$

But from ideal gas equation:

$$PV_{\text{perfect}} = nRT$$

or

$$V_{\text{perfect}} = \frac{nRT}{P}$$

Therefore

$$V_{\text{perfect}} = \frac{nRT}{P}$$

- * For ideal or perfect gases, the compressibility factor, $Z = 1$.
- * But for real gases, $Z \neq 1$.
- * For ideal or perfect gases, the compressibility factor, $Z = 1$.
- * But for real gases, $Z \neq 1$.

Case-I : If $Z > 1$

- * $V_{\text{real}} > V_{\text{ideal}}$
- * The repulsion forces become more significant than the attractive forces.
- * The gas cannot be compressed easily.
- * Usually the $Z > 1$ for so called permanent gases like He, H₂ etc.

Case-II: If $Z < 1$

- * $V_{\text{real}} < V_{\text{ideal}}$
- * The attractive forces are more significant than the repulsive forces.
- * The gas can be liquefied easily.
- * Usually the $Z < 1$ for gases like NH₃, CO₂, SO₂ etc.

The isotherms for one mole of different gases, plotted against the Z value and pressure, P at 0 °C are shown below:

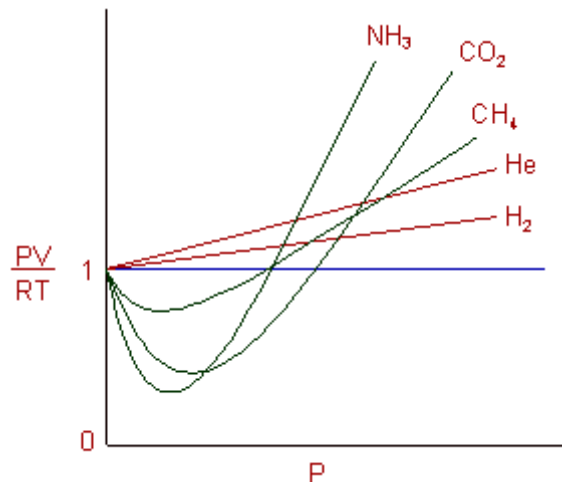

* For gases like He, H₂ the Z value increases with increase in pressure (positive deviation). It is because, the repulsive forces become more significant and the attractive forces become less dominant. Hence these gases are difficult to be condensed.

* For gases like CH₄, CO₂, NH₃ etc., the Z value decreases initially (negative deviation) but increases at higher pressures.

It is because: at low pressures, the attraction forces are more dominant over the repulsion forces, whereas at higher pressures the repulsion forces become significant as the molecules approach closer to each other.

* But for all the gases, the Z value approaches one at very low pressures, indicating the ideal behaviour.

Also consider the following graphs of Z vs P for a particular gas, N₂ at different temperatures.

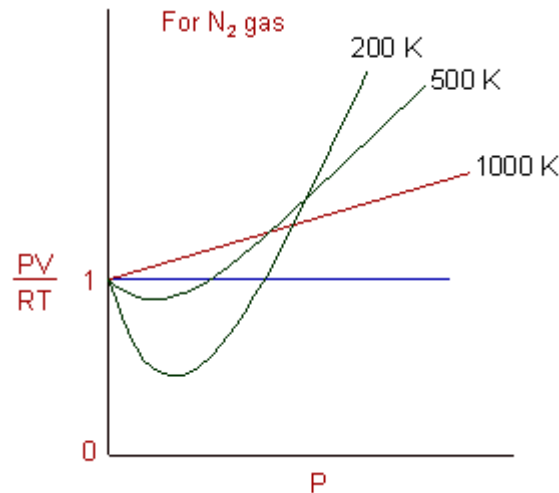

In above graphs, the curves are approaching the horizontal line with increase in the temperature i.e., the gases approach ideal behaviour at higher temperatures.

VAN DER WAALS EQUATION : DERIVATION

The deviations from ideal gas behaviour can be ascertained to the following faulty assumptions by kinetic theory of gases.

- * The real volume of the gas molecules is negligible when compared to the volume of the container.
- * There are no forces of attraction or repulsion between the gas molecules.

Hence van der Waal suggested the following corrections:

- * The gas molecules possess finite volume and hence should not be neglected. It is especially true at high pressures and low temperatures and should be accounted for.
- * In case of real gases, both the forces of attraction as well as repulsion operate between gas molecules.

Note: If the gases obey the kinetic theory of gases, then they cannot be compressed since the attractions between the gas molecules is negligible.

Also the following corrections are applied by van der Waals to the ideal gas equation:

Volume correction:

The volume available for the gas molecules is less than the volume of the container, V .

The available volume is obtained by subtracting excluded volume of 'n' moles of gas, nb from the volume of the container.

$$\text{Available volume} = V - nb$$

Where 'b' is a constant characteristic of a gas.

The ideal gas equation can be written after correcting for this as:

$$P(V-nb) = nRT$$

Pressure correction:

The pressure of the real gas is less than the expected pressure due to attractions between the molecules. These attractions slow down the motion of gas molecules and result in:

- i) reduction of frequency of collisions over the walls and
- ii) reduction in the force with which the molecules strike the walls.

Hence

$$P_{\text{ideal}} = P_{\text{real}} + p$$

Where p = reduction in pressure

However the reduction in pressure is proportional to the square of molar concentration, n/V .

$$\text{The reduction in pressure } (p) \propto \frac{n}{V} \times \frac{n}{V}$$

One factor for reduction in frequency of collisions and the second factor for reduction in strength of their impulses on the walls.

or

$$\text{Reduction in pressure } (p) = a \left(\frac{n}{V} \right)^2$$

where 'a' is a proportionality constant characteristic of a gas.

Therefore:

$$P_{\text{ideal}} = P_{\text{real}} + p = \left(P + a \frac{n^2}{V^2} \right)$$

Now the ideal gas equation can be modified once again by introducing this pressure correction as:

$$\left(P + a \frac{n^2}{V^2} \right) (V - nb) = nRT$$

This is known as van der Waals equation of state.

For one mole of a gas, the equation can be written as:

$$\left(P + \frac{a}{V_m^2} \right) (V_m - b) = RT$$

Where V_m = volume occupied by one mole of a real gas

Remember that:

P = observed pressure of the real gas

$$\left(P + a \frac{n^2}{V^2} \right) = \text{pressure corrected for ideal gas}$$

V = volume occupied by the real gas and is equal to the volume of the container.

whereas, $(V - nb)$ = available volume for gas molecules

Units of 'a' and 'b':

For 'a' ----- atm L² mol⁻²

For 'b' ----- L. mol⁻¹

CHARACTERISTICS OF VAN DER WAALS CONSTANTS: a & b

* 'a' is called van der Waals constant of attraction. Higher values of 'a' indicate greater attraction between gas molecules. The easily compressible gases like ammonia, HCl possess higher 'a' values.

Greater the value of 'a' for a gas easier is the liquefaction.

* 'b' is called excluded volume of the gas.

$$b = 4N_A \times \frac{4}{3} \pi r^3$$

Where N_A = Avogadro number and r = radius of molecule

* For a given gas, the numerical value of 'a' is greater than that of 'b'.

* The Boyle's temperature (T_B) and inversion temperature (T_i) are related to the two van der Waals constants as:

$$T_B = \frac{a}{bR} = \frac{1}{2}T_i$$

Note:

Boyle's temperature is the temperature at which the gases obey the ideal gas laws over a wide range of pressures.

Inversion temperature is the temperature at which the Joule Thompson coefficient changes its sign i.e., from positive to negative or vice versa.

MERITS & APPLICATIONS OF VAN DER WAAL'S EQUATION

- * The Vander Waal's equation holds good for real gases up to moderately high pressures.
- * It explains the isotherms of PV/RT vs P for various gases.
- * From this equation it is possible to obtain expressions for Boyle's temperature, critical constants and inversion temperature in terms of the Vander Waal's constants 'a' and 'b'.

Liquefaction of gases: The isotherms plotted between P vs V at different temperatures for one mole of CO_2 gas are shown below.

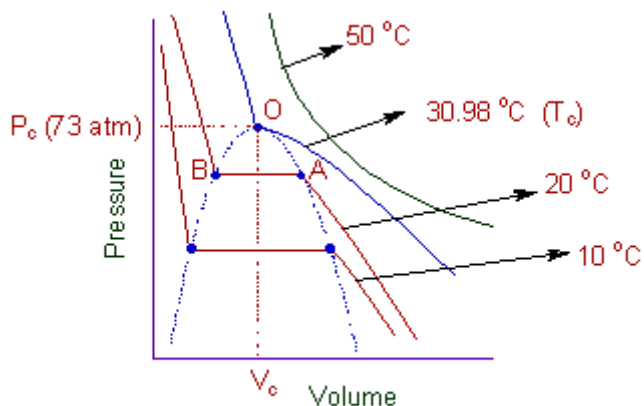

isotherms of CO_2 at different temperatures

Following conclusions can be drawn from these graphs:

- * At higher temperatures, say 50 °C, the isotherms show ideal behaviour.
- * As the temperature is lowered, the isotherms show deviation from ideal behaviour.
- * At 30.98 °C, carbon dioxide remains as gas up to 73 atm. But liquid appears for the first time at 73 atm (represented by point 'O'). Hence 30.98 °C is called critical temperature for CO_2 .

And above 73 atm. there is a steep rise in the pressure. This steep portion of the curve represents the isotherm of liquid state for which small decrease in volume results in steep rise in the pressure.

* At even lower temperature, 20 °C, the liquid appears at point 'A'. Further compression does not change the pressure up to point 'B'. After point, B the curve again becomes steep representing the isotherm for liquid CO₂.

Critical PROPERTIES

Critical Temperature (T_c): It is the temperature above which a gas cannot be liquefied by applying pressure.

$$T_c = \frac{8a}{27Rb}$$

Critical Pressure (P_c): It is the minimum pressure required to cause liquefaction at critical temperature, T_c.

$$P_c = \frac{a}{27b^2}$$

Critical Volume (V_c): It is the volume occupied by one mole of a gas at T_c and P_c.

$$V_c = 3b$$

Super critical fluid: The dense fluid obtained by compressing a gas above its critical temperature is called super critical fluid.

* It is not a liquid though its density is similar to that of liquid.

* It is not a gas due to high density and no distinct surface that separates it from the vapour phase.

* It can be used as a solvent.

E.g. The super critical fluid of CO₂ is used in the extraction of caffeine from coffee beans.

Derivation of critical constants from van der Waals constant:

The van der Waals equation for n moles is

$$\left(P + \frac{a n^2}{V^2}\right)(V - nb) = nRT \text{ ----- (6.22)}$$

For 1 mole

$$\left(P + \frac{a}{V^2}\right)(V - b) = RT \text{ ----- (6.23)}$$

From the equation we can derive the values of critical constants P_c , V_c and T_c in terms of a and b , the van der Waals constants, On expanding the above equation

$$PV + \frac{a}{V} - Pb - \frac{ab}{V^2} - RT = 0 \text{ ----- (6.24)}$$

Multiply equation (6.24) by V^2 / P

$$\frac{V^2}{P} \left(PV + \frac{a}{V} - Pb - \frac{ab}{V^2} - RT\right) = 0$$

$$V^3 + \frac{aV}{P} - bV^2 - \frac{ab}{P} - \frac{RTV^2}{P} = 0 \text{ --- (6.25)}$$

When the above equation is rearranged in powers of V

$$V^3 - \left[\frac{RT}{P} + b\right]V^2 + \left[\frac{a}{P}\right]V - \left[\frac{ab}{P}\right] = 0 \text{ --- (6.26)}$$

The equation (6.26) is a cubic equation in V . On solving this equation, we will get three solutions. At the critical point all these three solutions of V are equal to the critical volume V_c . The pressure and temperature becomes P_c and T_c respectively

$$V = V_c$$

$$V - V_c = 0$$

$$(V - V_c)^3 = 0$$

$$V^3 - 3V_c V^2 + 3V_c^2 V - V_c^3 = 0 \text{(6.27)}$$

As equation (6.26) is identical with equation (6.27), we can equate the coefficients of V^2 , V and constant terms in (6.26) and (6.27).

$$-3V_c V^2 = - \left[\frac{RT_c}{P_c} + b \right] V^2$$

$$3V_c = \frac{RT_c}{P_c} + b \quad \text{---- (6.28)}$$

$$3V_c^2 = \frac{a}{P_c} \quad \text{---- (6.29)}$$

$$V_c^3 = \frac{ab}{P_c} \quad \text{---- (6.30)}$$

Divide equation (6.30) by equation (6.29)

$$\frac{V_c^3}{3V_c^2} = \frac{ab/P_c}{a/P_c}$$

$$\frac{V_c}{3} = b$$

$$\text{i.e. } V_c = 3b \quad \text{----- (6.31)}$$

$$\text{i.e. } V_c = 3b \quad \text{----- (6.31)}$$

when equation (6.31) is substituted in (6.29)

$$3V_c^2 = \frac{a}{P_c}$$

$$P_c = \frac{a}{3V_c^2} = \frac{a}{3(3b^2)} = \frac{a}{3 \times 9b^2} = \frac{a}{27b^2}$$

$$P_c = \frac{a}{27b^2} \quad \text{----- (6.32)}$$

substituting the values of V_c and P_c in equation (6.28),

$$3V_c = b + \frac{R T_c}{P}$$

$$3(3b) = b + \frac{R T_c}{\left(\frac{a}{27 b^2}\right)}$$

$$9b - b = \left(\frac{R T_c}{a}\right) 27 b^2$$

$$8b = \frac{T_c R 27 b^2}{a}$$

$$\therefore T_c = \frac{8 a b}{27 R b^2} = \frac{8 a}{27 R b}$$

$$T_c = \frac{8 a}{27 R b} \quad \text{----- (6.33)}$$

The critical constants can be calculated using the values of van der waals constant of a gas and vice versa.

$$a = 3 V_c^2 P_c \quad \text{and} \quad b = \frac{V_c}{3}$$

DALTON'S LAW OF PARTIAL PRESSURES

Dalton's law of partial pressures states that the total pressure of a mixture of gases is the sum of the partial pressures of its components:

$$P_{\text{Total}} = P_{\text{gas 1}} + P_{\text{gas 2}} + P_{\text{gas 3}} \dots$$

where the partial pressure of each gas is the pressure that the gas would exert if it was the only gas in the container. That is because we assume there are no attractive forces between the gases.

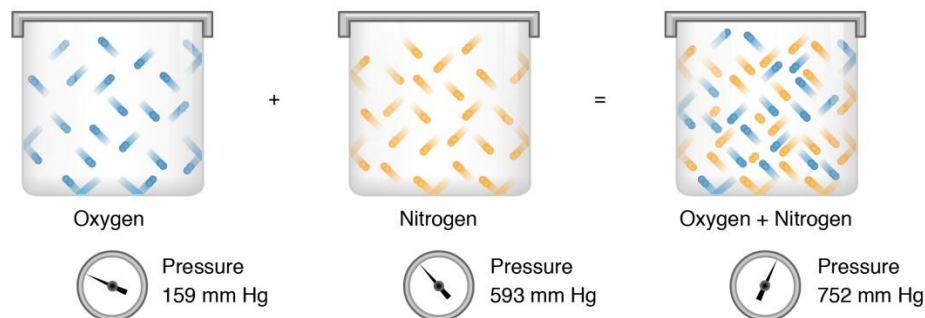

Dalton's law of partial pressure can also be expressed in terms of the mole fraction of a gas in the mixture. The mole fraction of a gas is the number of moles of that gas divided by the total moles of gas in the mixture, and it is often abbreviated as x_{11} :

$$x_1 = \text{mole fraction of gas 1} = \frac{\text{moles of gas 1}}{\text{total moles of gas}}$$

Dalton's law can be rearranged to give the partial pressure of gas 1 in a mixture in terms of the mole fraction of gas 1:

$$P_{\text{gas 1}} = x_1 P_{\text{Total}}$$

Both forms of Dalton's law are extremely useful in solving different kinds of problems including:

- Calculating the partial pressure of a gas when you know the mole ratio and total pressure
- Calculating moles of an individual gas if you know the partial pressure and total pressure
- Calculating the total pressure if you know the partial pressures of the components

AMAGAT'S LAW OF PARTIAL VOLUMES

Amagat's law of partial volumes asserts that the volume of a mixture is equal to the sum of the partial volumes of its components. For a mixture of components AA, BB, CC, etc., Amagat's law gives the volume as

$$V_{\text{mixture}} = V_A + V_B + V_C + \dots$$

For real gases, Amagat's law is usually an even better approximation than Dalton's law⁶⁶.

Again, for mixtures of ideal gases, it is exact. For an ideal gas, the partial volume is

$$V_A = n_A RT / P_{\text{mixture}}$$

$$\text{Since } n_{\text{mixture}} = n_A + n_B + n_C + \dots$$

we have, for a mixture of ideal gases,

$$V_{\text{mixture}} = n_{\text{mixture}} RT / P_{\text{mixture}}$$

$$= (n_A + n_B + n_C + \dots) RT / P_{\text{mixture}}$$

$$= V_A + V_B + V_C + \dots$$

Applied to the mixture, the ideal-gas equation yields Amagat's law. Also, we have $V_A = x_A V_{\text{mixture}}$

Beattie-Bridgman equation

An equation of state that relates the pressure, volume, and temperature of a gas and the gas constant. The Beattie-Bridgman equation uses empirical constants to take into account the reduction in the effective number of molecules due to various types of molecular aggregation.

It is given by

$$P = RT(1 - \epsilon)(V+B)/V^2 - A/V^2,$$

where P is the pressure,

T is the thermodynamic temperature,

V is the volume,

R is the gas constant,

and A , B , and ϵ are constants related to five empirical constants A_0 , B_0 , a , b , and c by: $A = A_0(1 - a/V)$, $B = B_0(1 - b/V)$, and $\epsilon = c/VT^3$.

$$P = RT(1 - \epsilon)(V+B)/V^2 - A/V^2$$

Problems

- Carbon Dioxide gas is stored in a 100 liter tank at 6 MPa and 30°C. Determine the mass of CO₂ in the tank based on (a) values obtained from the CO₂ tables of data, (b) the ideal gas equation of state, and (c) the generalized compressibility chart. Compare (b) and (c) to (a) and determine the percentage error in each case.

Solution Approach:

We first determine the Critical Point data for CO₂ from the [Table of Critical Point Data of Various Substances](#)

$P_{CR} = 7.39 \text{ MPa}$, $T_{CR} = 304.2 \text{ K}$
 $P_r = \left(\frac{P}{P_{CR}} \right) = \left(\frac{6 \text{ MPa}}{7.39 \text{ MPa}} \right) = 0.81$
 $T_r = \left(\frac{T}{T_{CR}} \right) = \left(\frac{303 \text{ K}}{304.2 \text{ K}} \right) \approx 1.0$

Compressibility Factor:
 $Z = 0.62$
 (As read from the Compressibility Chart. Be sure to understand this process)

After evaluating the Reduced Pressure and Reduced Temperature we plot them on the [Generalized Compressibility Chart](#) in order to determine the Compressibility Factor, as shown below

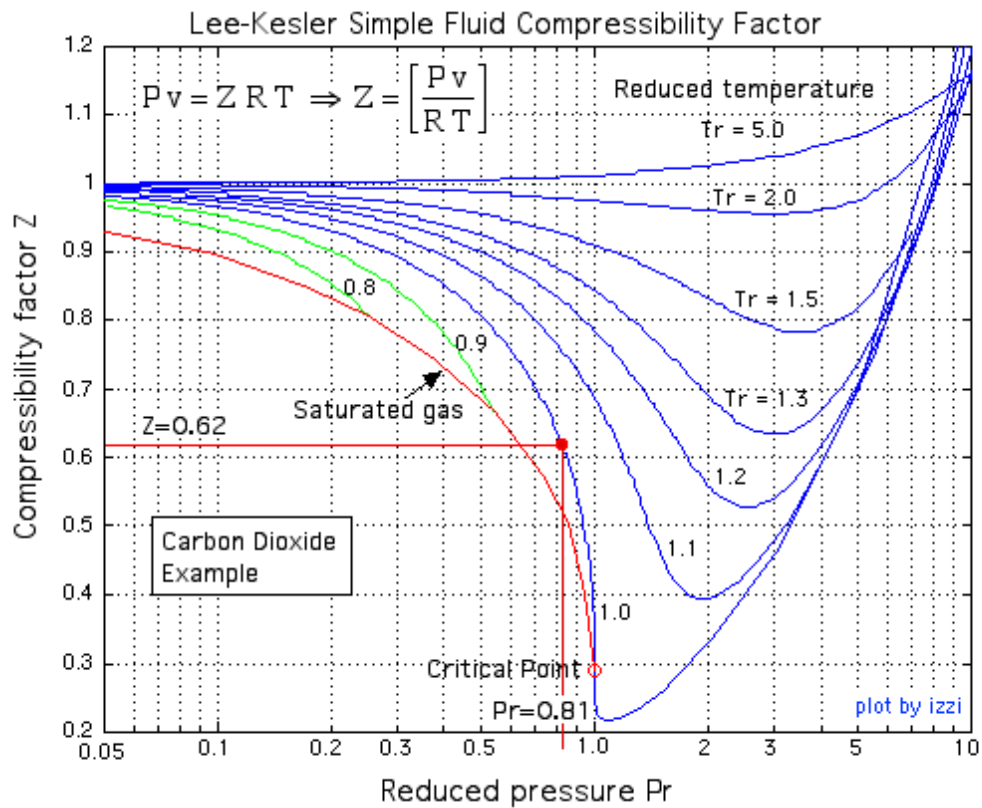

The actual value of specific volume v_a is obtained from the [CO₂ Superheat Tables](#)

(a) Actual value of $v_a = 0.005833 \text{ [m}^3/\text{kg]}$

$$\Rightarrow \text{actual mass } m_a = \left[\frac{V}{v_a} \right] = \left[\frac{0.1 \text{ m}^3}{0.005833 \text{ [m}^3/\text{kg}]} \right] = 17.14 \text{ kg} \rightarrow$$

(b) Using the Ideal Gas Equation of State:

$$P v_i = R T \Rightarrow v_i = \frac{R T}{P}, \text{ where } R = 0.1889 \left[\frac{\text{kJ}}{\text{kg K}} \right]$$

$$v_i = \frac{0.1889 \left[\frac{\text{kJ}}{\text{kg K}} \right] 303 \text{ K}}{6000 \text{ kPa}} = 0.00954 \text{ [m}^3/\text{kg]}$$

$$\Rightarrow \text{ideal mass } m_i = \left[\frac{V}{v_i} \right] = \left[\frac{0.1 \text{ m}^3}{0.00954 \text{ [m}^3/\text{kg}]} \right] = 10.5 \text{ kg}$$

39% error 

(c) Using the Compressibility Factor Z:

$$P v_z = Z R T \Rightarrow v_z = Z \left[\frac{R T}{P} \right] = Z v_i = 0.62 v_i \text{ (from above)}$$

$$v_z = (0.62)(0.00954 \text{ [m}^3/\text{kg]}) = 0.00591 \text{ [m}^3/\text{kg]}$$

$$\Rightarrow \text{mass } m_z = \left[\frac{V}{v_z} \right] = \left[\frac{0.1 \text{ m}^3}{0.00591 \text{ [m}^3/\text{kg}]} \right] = 16.9 \text{ kg}$$

1% error 

The general rule is that if $P \ll P_{CR}$ or if $T \gg T_{CR}$ then you are probably dealing with an ideal gas. If in doubt *always* check the Compressibility Factor Z on the Compressibility Chart.

2. You may wonder why we would be interested in knowing the value of air pressure at 3000m altitude. In the following example we continue with the above development in order to evaluate the payload that can be lifted to an altitude of 3000m using a small hot air balloon (Volume = 1000 m³) having an empty mass of 100kg. Assume that the temperature of the air in the balloon is 100°C.

Solution Approach:

In this case we develop the solution in terms of a force balance between the buoyancy force (weight of the displaced air) and the gravity force including the weight of the hot air, the balloon empty mass, and the payload mass. The maximum altitude occurs when those two forces are equal, as follows:

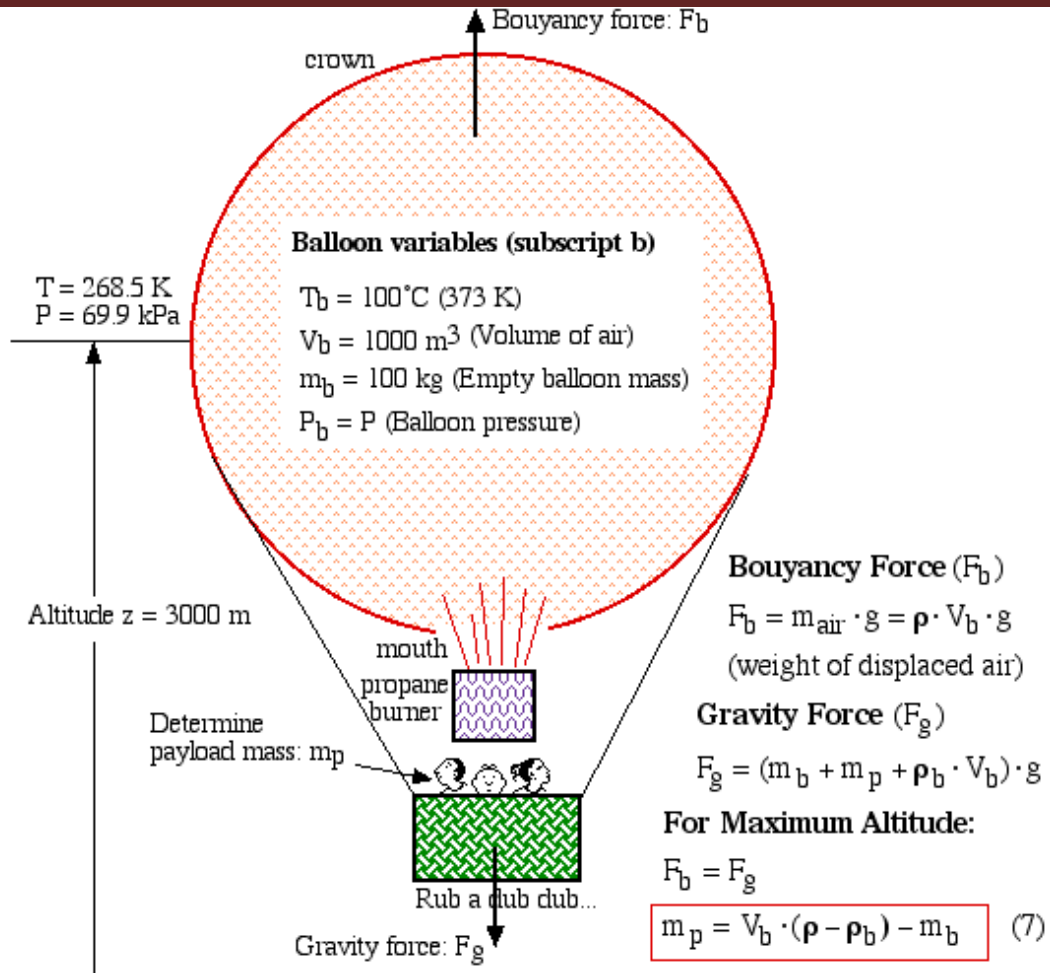

Density (ρ)

$$P = \rho \cdot R \cdot T \Rightarrow \rho = \frac{P}{R \cdot T} = \frac{(69.9 \times 1000 \text{ Pa})}{(287) \cdot (268.5 \text{ K})} = 0.907 \text{ kg/m}^3$$

$$P = P_b \Rightarrow \rho \cdot R \cdot T = \rho_b \cdot R \cdot T_b \Rightarrow \rho_b = \rho \cdot \left(\frac{T}{T_b} \right) \quad (8)$$

$$\rho_b = 0.907 \cdot \left(\frac{268.5 \text{ K}}{373 \text{ K}} \right) = 0.653 \text{ kg/m}^3$$

Payload Mass (from equation (7))

$$m_p = V_b \cdot (\rho - \rho_b) - m_b = 1000 \cdot (0.907 - 0.653) - 100 = 154 \text{ kg}$$

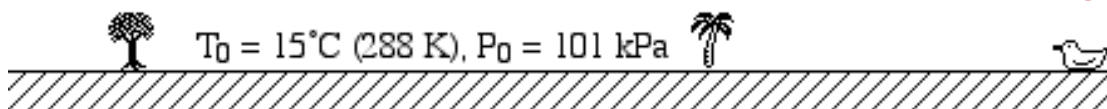

3. A piston-cylinder device contains 0.5 kg saturated liquid water at a pressure of 200 kPa. Heat is added and the steam expands at constant pressure until it reaches 300°C.

- a) Draw a diagram representing the process showing the initial and final states of the system.
- b) Sketch this process on a T - v (temperature-specific volume) diagram with respect to the saturation lines, critical point, and relevant constant pressure lines, clearly indicating the initial and final states.
- c) Using steam tables determine the initial temperature of the steam prior to heating.
- d) Using steam tables determine the final volume of the steam after heating
- e) Using the ideal gas equation of state determine the final volume of the steam after heating. Determine the percentage error of using this method compared to that of using the steam tables.

Note: The critical point data and the ideal gas constant for steam can be found on the first page of the [steam tables](#).

Solution Approach:

Even if questions a) and b) were not required, this should always be the first priority item in solving a thermodynamic problem.

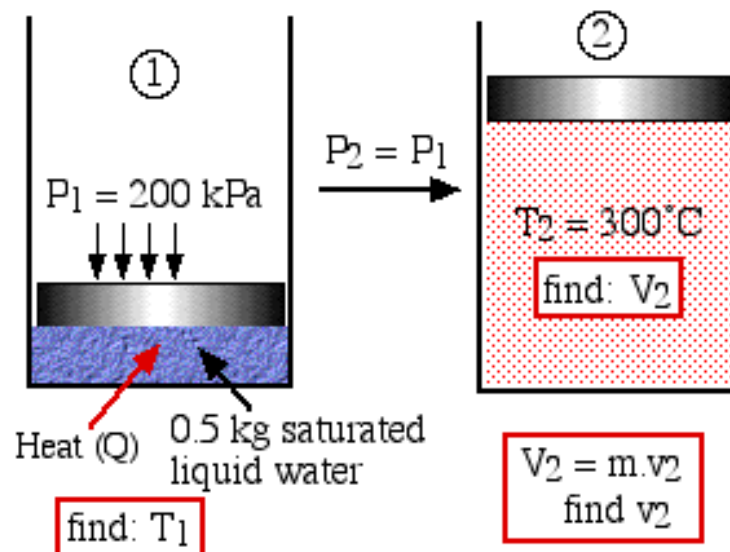

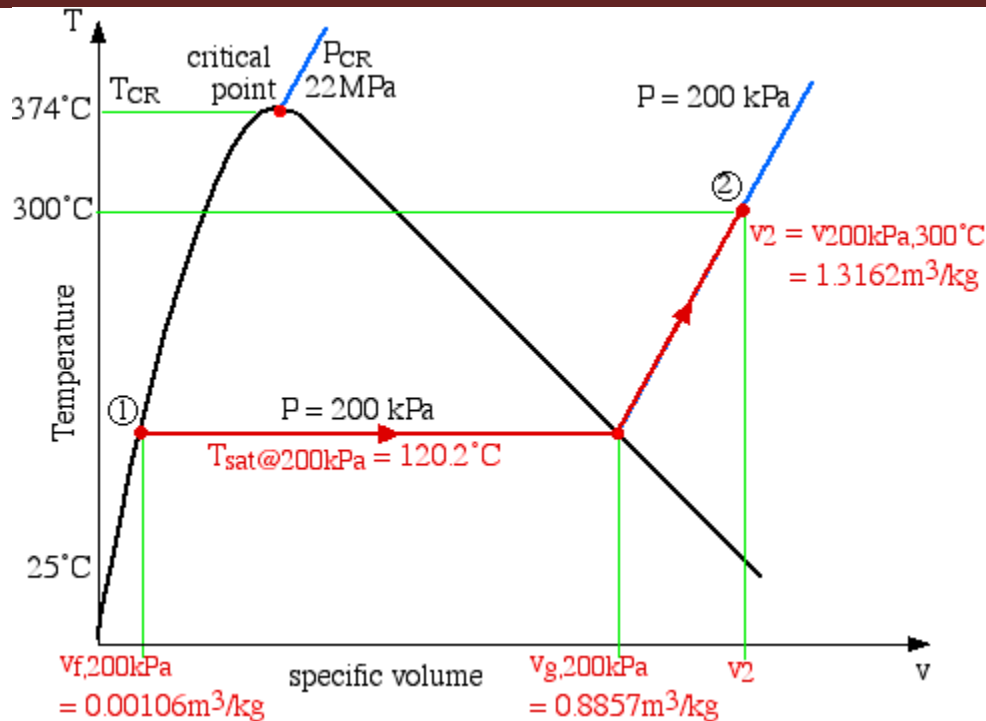

c) Since state (1) is specified as saturated liquid at 200 kPa, we use the [saturated pressure steam tables](#) to determine that $T_1 = T_{\text{sat}@200\text{kPa}} = 120.2^\circ\text{C}$.

d) From the T-v diagram we determine that state (2) is in the superheated region, thus we use the [superheated steam tables](#) to determine that $v_2 = v_{200\text{kPa},300^\circ\text{C}} = 1.3162 \text{ m}^3/\text{kg}$. Thus $V_2 = m \cdot v_2 = (0.5\text{kg}) \cdot (1.3162 \text{ m}^3/\text{kg}) = 0.658 \text{ m}^3$ (658 liters)

e) Determine V_2 from the Ideal Gas Equation of State

$$P \cdot V = m \cdot R \cdot T \Rightarrow V = \frac{m \cdot R \cdot T}{P} \quad T \text{ MUST be absolute!}$$

$$V_2 = \frac{0.5 \text{ [kg]} \cdot (0.4615) \left[\frac{\text{kJ}}{\text{kg} \cdot \text{K}} \right] \cdot (300 + 273) \text{ K}}{200 \text{ [kPa]}} = 0.661 \text{ m}^3$$

Note that in doing a units check we find that the following conversion appears so often that we feel it should be added to our Units Conversion Survival Kit (recall [Chapter 1](#)):

$$\boxed{\text{kPa} \cdot \text{m}^3} \Rightarrow \left[\frac{\text{kN}}{\text{m}^2} \right] \cdot \text{m}^3 \Rightarrow \text{kN} \cdot \text{m} \Rightarrow \boxed{\text{kJ}}$$

Finally we determine the percentage error of using the ideal gas equation at state (2)

$$\begin{aligned} \text{error}\% &= \left| \frac{(\text{true value}) - (\text{estimated value})}{(\text{true value})} \right| \cdot 100 \\ &= \left| \frac{0.658 - 0.661}{0.658} \right| \cdot 100 = 0.5\% \end{aligned}$$